

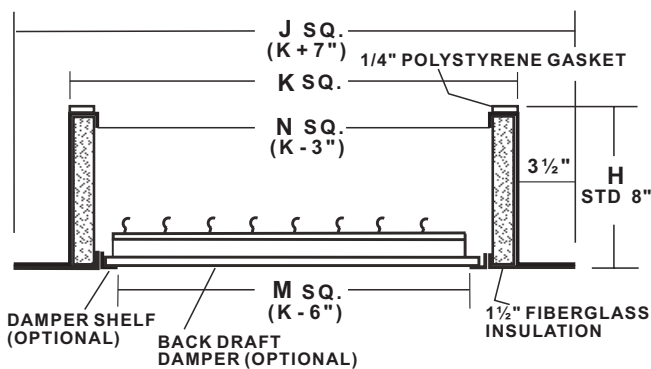

TYPE SF SELF-FLASHING CURB

STANDARD FEATURES

- Constructed of 18 ga. galv. steel with continuous welded seams and integral base plate for water tightness and extra strength.
- Wide base flashing to insure adequate bond to roofing surface for water tight seal to roof.
- Lined with 1-1/2" fire proof sound attenuating thermal insulation.
- Top of curb covered with 1/4" polystyrene gasket for weather seal and to reduce metal to metal conducted noise.



PROJECT	
LOCATION	
ARCHITECT	
ENGINEER	
CONTRACTOR	
SUBMITTED BY	
DATE	P.O. NO.

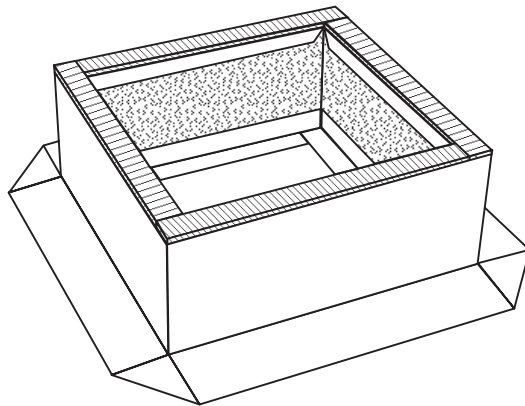

OPTIONS

- Constructed of .063" aluminum.
- Interior metal liner.
- Standard heights of 12, 14, 16, 18, 20, 24", or any special height.
- Damper shelf - standard or custom size opening.
- Wide flange (6" or 8" wide).
- Backdraft damper.
- Protective or decorative coatings.
- Heavy-gauge construction.

SPECIFICATIONS AND DIMENSIONS

REFERENCE	QUANTITY	GALV. OR ALUM.	K	N	M	H	OPTIONS