

CONNECT WIRING DIAGRAM

Switch Box by Others

1. For DC fan

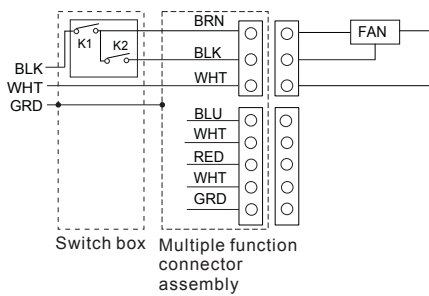

2. For DC fan with humidity sensor

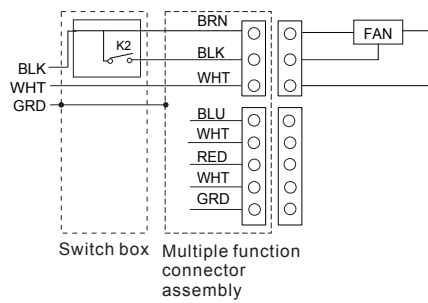

3. For DC fan with motion sensor

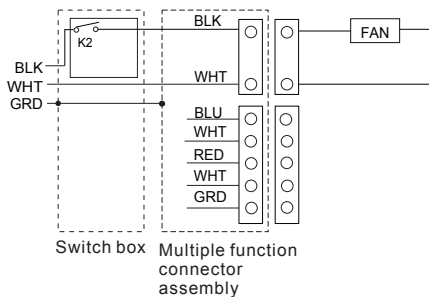

4. For DC fan with humidity sensor and motion sensor

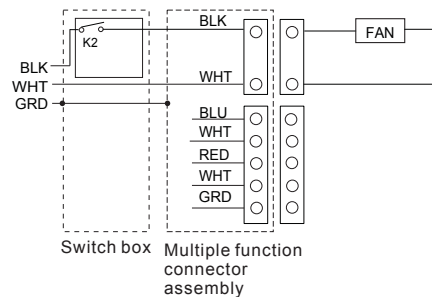

5. For DC fan with humidity sensor and VOC sensor

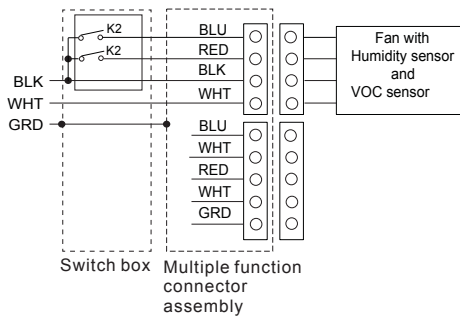

6. For DC fan with light and night light

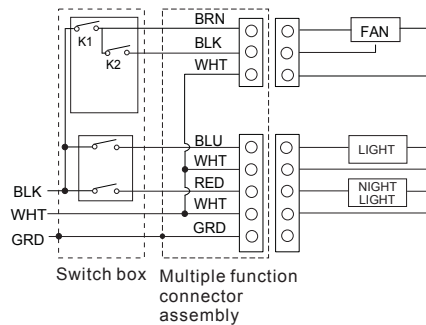

7. For DC fan with light, night light and humidity sensor

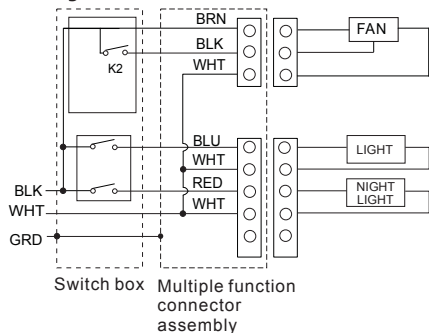

8. For DC fan with light, night light humidity sensor and VOC sensor

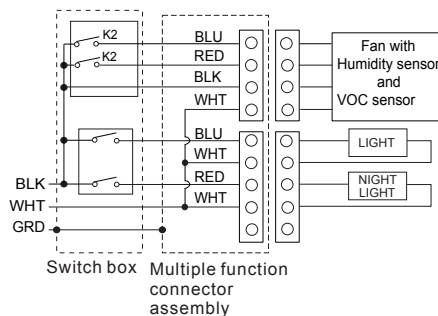

9. For DC fan with light, night light and motion sensor

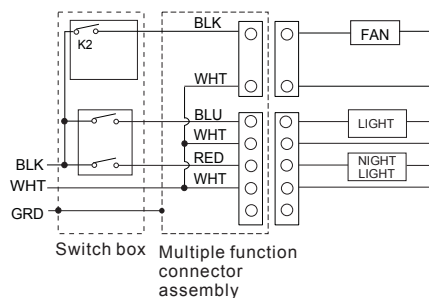

10. For DC fan with light, night light , humidity sensor and motion sensor

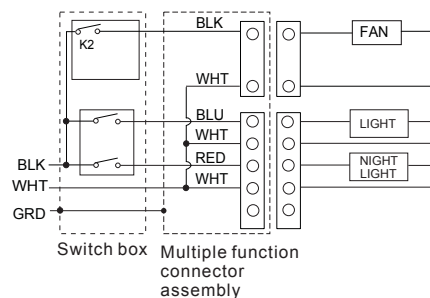

* Under sensor status the K2 should be turned on to get high speed.