

KIT - PV-100xps, DBF-100xc and DBM-100xp

(Dryer Boosting Kits)

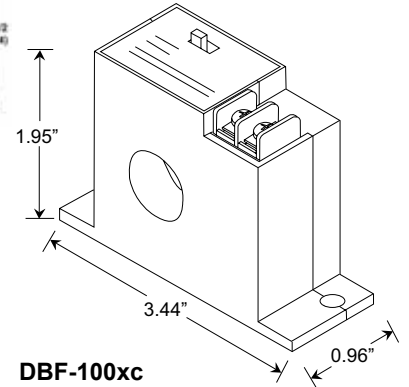

The World's Leading Producer of
Air Movement Products
6393 Powers Avenue
Jacksonville, Florida 32217
P: 800.961.7370 F: 800.961.7379
www.solerpalau-usa.com

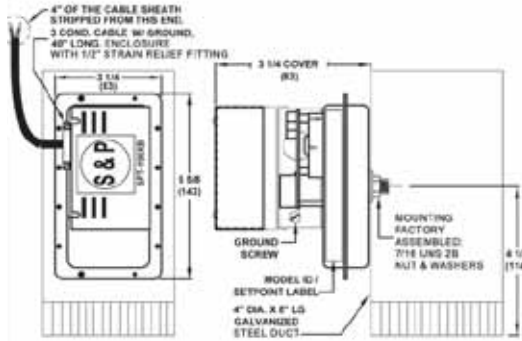

PV-100xps Clothes Dryer Exhaust Booster Kit with Integrated Pressure Sensor Switch

This Premium Dryer Booster Kit
Includes the Following Components:

1. PV-100x Duct Boosting Fan (142 CFM)
2. Integrated Air Pressure Sensing Switch with electronic cycle timing board
3. Fan Mounting Bracket

DBM-100xp Clothes Dryer Exhaust Booster Kit with Duct Mounted Pressure Sensor Switch

This Premium Dryer Booster Kit
Includes the Following Components:

1. PV-100x Duct Boosting Fan (142 CFM)
2. Duct Mounted and pre-wired Air Pressure Sensing Switch with electronic cycle timing board
3. Fan Mounting Bracket

DBF-100xc Clothes Dryer Exhaust Booster Kit with Current Sensor

This Premium Dryer Booster Kit Includes
the Following Components:

1. PV-100x Duct Boosting Fan (142 CFM)
2. CS-325 High Current Sensing Switch
3. Fan Mounting Bracket

Dimensions inches/mm

Model	A	B	C	D	E	F	G	Weight lbs(kgs)
PV-100x	3 ^{13/16} 97.5	3 ^{13/16} 97.5	4 ^{3/4} 120	7 ^{11/16} 196	7 ^{1/2} 190	4 ^{3/4} 120	9 ^{9/16} 243	7 3.0



Air Performance

Model No.	Nom. RPM	Volts	Max. Watts	CFM v Static Pressure (SP) Ins. WG									Max. SP	Duct Dia. Ins.
				0"	0.125"	0.25"	0.375"	0.5"	0.75"	1.0"	1.25"	1.5"		
PV-100x	2880	115	84	153	142	130	120	111	96	80	63	34	1.85	4"

For more information contact us at www.solerpalau-usa.com or 1.800.961.7370 for additional submittal drawings.
Soler & Palau will not be responsible for fabrication changes or errors resulting from customer use of a non-current submittal drawing.

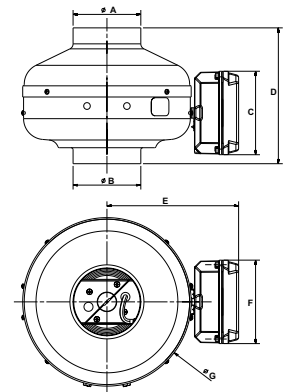

MOTOR DATA					
AMPS	RPM	VOLTS	PH	HZ	ENCLOSURE

ACCESSORIES	1	2	3	4	5	REMARKS

PROJECT: _____
LOCATION: _____
FORM NO.: _____
ENGINEER: _____

CONTRACTOR: _____
REVISION DATE: _____
SUBMITTED BY: _____
APPROVED BY: _____

DATE: _____
DATE: _____