

# MODEL UBS BELT DRIVE UPBLAST PROPELLER ROOF EXHAUSTER



6393 Powers Avenue  
Jacksonville, Florida 32217-2298  
P: 800.961.7370 / F: 800.961.7379  
www.solerpalau-usa.com

## STANDARD CONSTRUCTION FEATURES

- Galvanized Steel Butterfly Dampers.
- Galvanized Steel Windband.
- Lifting Eyes at All Four Corners of Curb Cap.
- Galvanized Curb Cap with Fully Welded Corners.
- Heavy Galvanized Schedule 40 Pipe Frame.
- Cast Iron Pillow Block Bearings with Lube Fittings. Average Life of 200,000 Hours.
- V Belt Drive with Adjustable Motor Sheave.  
(Standard through 3HP)
- Nationally Recognized and Locally Serviced Motor.
- Heavy Epoxy Coated Steel Hub Plate. Keyed to Fan Shaft.
- Die Formed Epoxy Coated Steel Propeller Blades.
- Integral Galvanized Steel Rain Channel.
- Stainless Steel Damper Rod.
- cULus Listed - Standard 705 (optional).

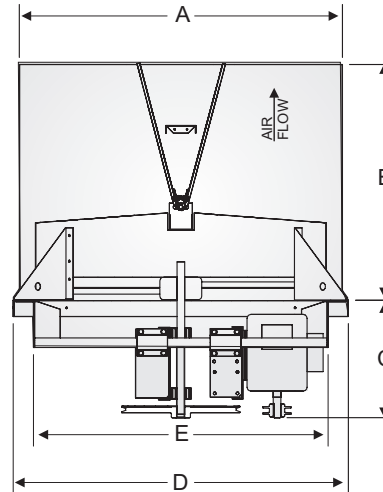

Soler&Palau  
Ventilation Group



Model UBS	A	B	C	D	E	F	Metal Gauges		Average Wt. Lbs.
							Wind Shroud	Fan Panel	
24	30	26	20	32	28	31	18	16	250
30	36	29	21	38	34	37	18	16	325
36	42	31	21	44	40	43	18	16	350
42	48	34	22	50	46	49	18	16	425
48	54	37	26	56	52	55	18	16	450
54	60	40	26	62	58	61	18	14	575
60	66	43	26	68	64	67	18	14	750

- A** - Outside Diameter of Windband.
- B** - Height of Unit Above Curb Cap.
- C** - Maximum Depth of Unit Below Top of Curb, Actual Depth Varies with Motor Size.
- D** - Inside Dimension of Square Curb Cap.
- E** - Minimum Inside Dimension of Curb Opening Required for Adequate Clearance of Fan Frame.
- F** - Outside Dimension of Factory Built Pre-fab Curb.

FAN SPECIFICATIONS									MOTOR SPECIFICATIONS				
Line	Qty.	Model No.	Tag	CFM	SP	Fan RPM	BHP	Sones	HP	Volts	Phase	Hertz	Encl
1													
2													
3													
4													
5													

ACCESSORY ITEMS					ACCESSORY ITEMS				
1	2	3	4	5	1	2	3	4	5

Project: \_\_\_\_\_ Submitted: \_\_\_\_\_  
 Customer: \_\_\_\_\_ Approved: \_\_\_\_\_  
 Location: \_\_\_\_\_