

MODEL TXB-HWL BELT DRIVE CENTRIFUGAL UPBLAST ROOF EXHAUSTER CERTIFIED HIGH WIND LOAD (HWL) CONSTRUCTION OPTION

Miami-Dade County, Florida NOA 09-0513.02 (expires 9-9-2014)

STANDARD CONSTRUCTION FEATURES

- High strength internal support and external stainless steel wire tie downs
- High efficiency, dynamically balanced non-stalling backward inclined wheel.
- Motor and drive assembly isolated from air stream and external environment for extended life.
- 1 or 3ph ODp, TEfC, Explosion proof or premium Efficiency motors available.
- **Ideally suited for coastline installations** includes stainless steel fasteners and non-corrosive materials.
- nEMA disconnect switches available.

SIZE	DIMENSIONS (IN.)					AVG. SHIP WT. (LBS)
	A	B	C	D	E	
8	16 1/2	24	24	27	1 3/4	69
10	16 1/2	27	26	29	1 3/4	69
12/15/16	24	31 1/2	26	29	2 1/2	93
18/20	29 1/2	37 3/4	28 1/2	32	2 1/2	120
24	35 1/2	47 1/4	31 1/2	42	2 1/2	245
30	42 1/2	56 3/4	41	45	2 1/2	365
36	42 1/2	66	44	48	2 1/2	365
42	55	72 1/2	48	52	2 1/2	385
48	55	78 3/4	52	56	2 1/2	490

A - Inside dimension of square curb cap. D - Height of unit above top of curb.
 B - Outside diameter of unit. E - Depth of curb mounting fange.
 C - Height of exhaust opening above curb cap.

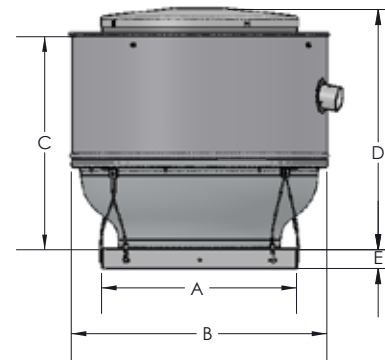

DIMEnSIOnS rEPREsENT gENERAl CONsTRuCTIOn ANd MAY VArY sllgHTly. CONtACT fACTOrY fOr CERtIFIED DrAwIngs.

NOTES:

1. MODEL TXB HAS BEEN SUCCESSFULLY TESTED IN ACCORDANCE WITH MIAMI DADE TEST PROTOCOL TAs-201 (IARgE MIssILE IMPACT); TAs-202 (sTATIC lOADIng); TAs-203 (CyClIC wInD prEssurE lOADIng).
2. rOOf sTRuCTurE MusT BE DEsIGNED TO wITHsTANd THE wElGHt ANd lOADIng TrAnsMITTED By rOOf TOp fAns. fAsTEnErS sHAlI BE As spECIFIED ANd InsTAlIEd As DETAlIEd.
3. DEsIGN TEsTInG ANd InsTAlIATIOn CONfOrMs TO 2007 fIORIDA BuILDInG CODE ANd ITs 2005 ANd 2006 sUpPlEMENtS.
4. CERtIFIED HwL fAn CurBs MusT BE ANCHORed TO rOOf fRAMInG MEMBErS ANd NOT TO THE rOOFlInG sYsTEM.

FAN SPECIFICATIONS									MOTOR SPECIFICATIONS				
Line	Qty.	Model No.	Tag	CFM	SP	Fan RPM	BHP	Sones	HP	Volts	Phase	Hertz	Encl
1													
2													
3													
4													
5													

ACCESSORY ITEMS	1	2	3	4	5	ACCESSORY ITEMS	1	2	3	4	5
<input type="checkbox"/>						<input type="checkbox"/>					
<input type="checkbox"/>						<input type="checkbox"/>					
<input type="checkbox"/>						<input type="checkbox"/>					
<input type="checkbox"/>						<input type="checkbox"/>					
<input type="checkbox"/>						<input type="checkbox"/>					

project: _____ submitted: _____
 Customer: _____ Approved: _____
 Location: _____



6393 powers Avenue
 Jacksonville, Florida 32217-2298
 p: 800.961.7370 / f: 800.961.7379
 www.solerpalau-usa.com



OPTIONAL
 (Must be specified)
 cULus 705
 cULus 762 (Grease)

