

# MODEL RCXII (sizes 24-36) CURB MOUNT SPUN ALUMINUM GRAVITY VENTILATORS



6393 Powers Avenue  
Jacksonville, Florida 32217-2298  
P: 800.961.7370 / F: 800.961.7379  
www.solerpalau-usa.com



## STANDARD FEATURES

- Five year warranty
- Low contour spun aluminum hood for attractive appearance.
- All heavy-gauge aluminum
- Weather resistant design for long life and maintenance free operation.
- Galvanized birdscreen is standard.
- Available in 11 sizes for a wide range of performance capabilities.
- One piece welded curb cap with round spun inlet for maximum efficiency.
- Shipped completely assembled for ease in installation.
- Intake or exhaust.
- Low pressure drop

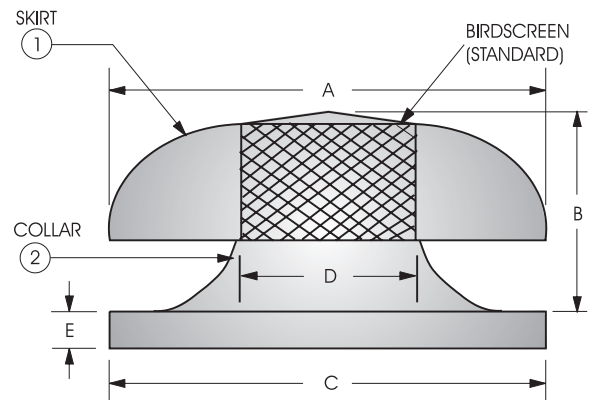

Optional factory prefabricated curbs available to fit all sizes of units listed.

Model No.	Throat Area sq. ft.	Dimensions (in.)					Material Gauge		Estimated Weight	Nominal Damper Size
		A	B	C	D	E	1	2		
24	3.30	43-3/4	12-1/2	35-1/2	24-5/8	2	0.063	0.063	57	27 x 27
26	3.69	43-3/4	17-3/8	35-1/2	26	2	0.063	0.063	57	27 x 27
30	5.16	43-3/4	17-3/8	42-1/2	30-3/4	2	0.063	0.080	75	34 x 34
33	5.94	54-3/4	17-3/8	42-1/2	33	2	0.100	0.080	75	34 x 34
36	7.06	54-3/4	17-3/8	42-1/2	36	2	0.100	0.080	90	34 x 34

ACCESSORY ITEMS	1	2	3	4	5	ACCESSORY ITEMS	1	2	3	4	5
<input type="checkbox"/>						<input type="checkbox"/>					
<input type="checkbox"/>						<input type="checkbox"/>					
<input type="checkbox"/>						<input type="checkbox"/>					
<input type="checkbox"/>						<input type="checkbox"/>					
<input type="checkbox"/>						<input type="checkbox"/>					

Project: \_\_\_\_\_ Submitted: \_\_\_\_\_  
 Customer: \_\_\_\_\_ Approved: \_\_\_\_\_  
 Location: \_\_\_\_\_