

# MODEL LCE (Exhaust) & LCS (Supply) SIDEWALL PROPELLER FAN - BELT DRIVE LEVEL 1 CONSTRUCTION



6393 Powers Avenue  
Jacksonville, Florida 32217-2298  
P: 800.961.7370 / F: 800.961.7379  
www.solerpalau-usa.com

Soler&Palau Ventilation Group



Standard 705  
(Optional)

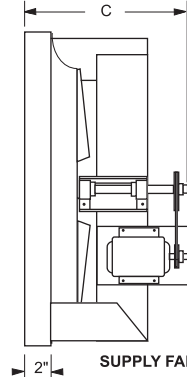
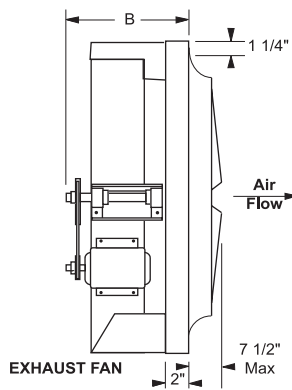
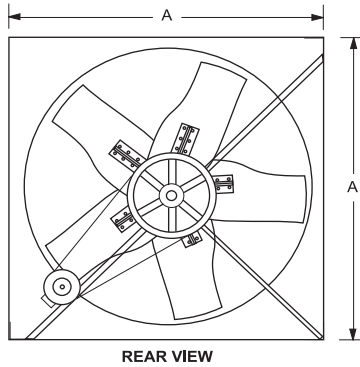

SIZE	A SQ. O.D. PANEL	B EXHAUST	C SUPPLY	APPROX WT.	MAX MOTOR	MATERIAL GAUGE OR THICKNESS				
						SHAFT	PANEL	SUPPORT FRAME	BLADES	HUB SPIDER
20	24	15	23	85	56H	3/4	18	16	18	14
24	30	15	23	90	145T	1	16	12	16	10
30	36	15	24	100	145T	1	16	12	16	10
36	42	15	24	105	145T	1	16	12	16	7
42	48	16	24	110	145T	1	16	12	14	7
48	54	16	24	125	145T	1	16	12	14	7
54	60	20	26	240	182T	1-3/16	14	12	14	1/4
60	66	20	26	285	182T	1-3/16	14	12	14	1/4

### CONSTRUCTION AND MATERIAL SPECIFICATION - LEVEL 1

**Fan panel, support frame, motor & bearing mounts** - all welded G90 galvanized steel.

**Fan Blades** - Die formed G90 galvanized, bolted to hub.

**Hub** - Die formed steel, epoxy coated, keyed to shaft.

**Bearings** - Air handling, self aligning, cast iron pillow block with grease fittings, L50 = 200,000 hours average life.

**Shaft** - Turned, ground and polished, keyed to propeller hub and sheave.

**Drives** - Cast iron, 150% S.F., single groove and adjustable thru 3HP, keyed to motor and fan shaft.

**Belts** - Nonstatic conducting, oil resistant, single groove thru 3HP.

FAN SPECIFICATIONS									MOTOR SPECIFICATIONS				
Line	Qty.	Model No.	Tag	CFM	SP	Fan RPM	BHP	Sones	HP	Volts	Phase	Hertz	Encl
1													
2													
3													
4													
5													

ACCESSORY ITEMS					ACCESSORY ITEMS				
1	2	3	4	5	1	2	3	4	5