

MODEL L3E (Exhaust) & L3S (Supply) SIDEWALL PROPELLER FAN - BELT DRIVE LEVEL 3 CONSTRUCTION

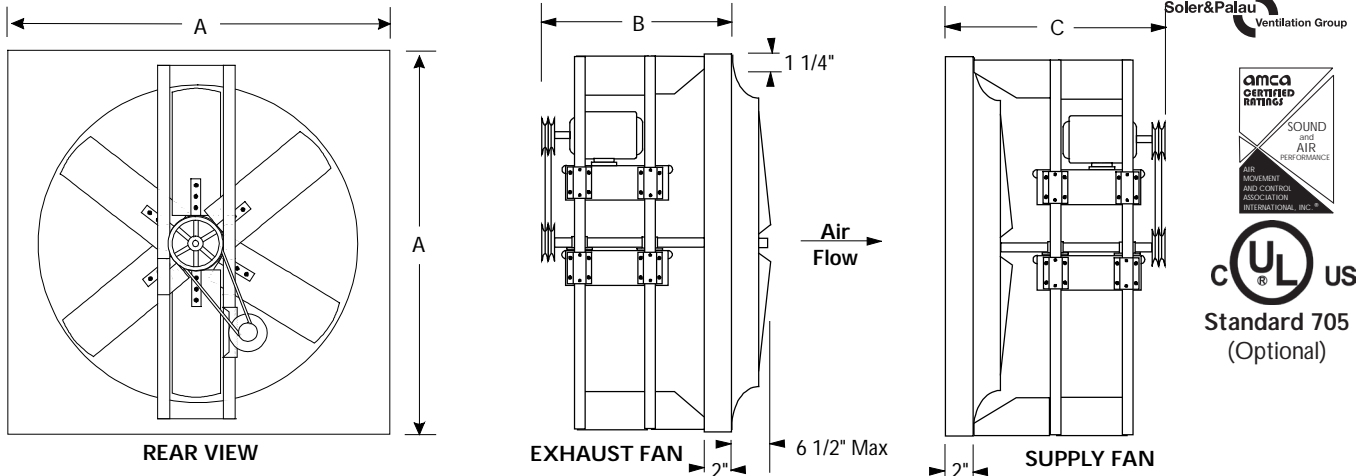

6393 Powers Avenue
Jacksonville, Florida 32217-2298
P: 800.961.7370 / F: 800.961.7379
www.solerpalau-usa.com



SIZE	A SQ. O.D. PANEL	B EXHAUST	C SUPPLY	APPROX WT.	MAX MOTOR	MATERIAL GAUGE OR THICKNESS								
						SHAFT	PANEL		SUPPORT FRAME		BLADES		HUB	PIPE FRAME
							Galv	Alum	Galv	Alum	Galv	Alum		
42	48	24	28	260	213T	1-7/16	16	.08	10	1/4	16	.08	3/8	1-1/4" OD SCHED. 40
48	54	24	28	330	215T	1-7/16	16	.100	10	1/4	16	.08	3/8	
54	60	24	28	500	254T	2-3/16	14	.100	10	1/4	16	.08	3/8	
60	66	24	28	530	256T	2-3/16	14	.100	10	1/4	16	.08	3/8	
72	80	24	28	600	256T	2-3/16	14	.100	10	1/4	16	.08	3/8	

CONSTRUCTION AND MATERIAL SPECIFICATION - LEVEL 3

Fan panel, motor & bearing mounts - all welded G90 galvanized steel.
Pipe support frame - H.D. four post welded 1 1/4" OD schedule 40 galvanized pipe.
Fan Blades - G90 galvanized (multiple laminations), bolted to hub.
Hub - Heavy-duty welded steel, epoxy coated, keyed to shaft.
Bearings - Air handling, self aligning, cast iron pillow block with grease fittings, L50 = 200,000 hours average life.

Shaft - Turned, ground and polished, keyed to propeller hub and sheave.
Drives - Cast iron, 150% S.F., single groove and adjustable thru 3HP, keyed to motor and fan shaft.
Belts - Nonstatic conducting, oil resistant, single groove thru 3HP.

FAN SPECIFICATIONS									MOTOR SPECIFICATIONS				
Line	Qty.	Model No.	Tag	CFM	SP	Fan RPM	BHP	Sones	HP	Volts	Phase	Hertz	Encl
1													
2													
3													
4													
5													

ACCESSORY ITEMS					1	2	3	4	5	ACCESSORY ITEMS					1	2	3	4	5