

MODELS HREB-C & HRED-C HOOD POWER ROOF EXHAUST VENTILATORS

Model HREB-C Belt Driven Aluminum Airfoil Props
Model HRED-C Direct Driven Aluminum Airfoil Props



6393 Powers Avenue
Jacksonville, Florida 32217-2298
P: 800.961.7370 / F: 800.961.7379
www.solerpalau-usa.com

Soler&Palau
Ventilation Group



Standard 705
(Optional on HREB-C only)

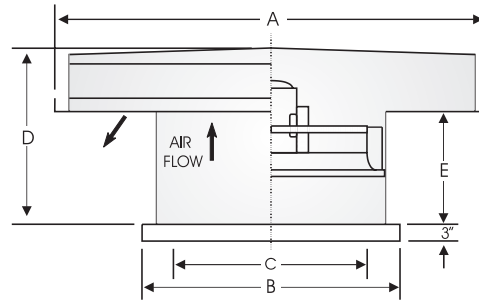
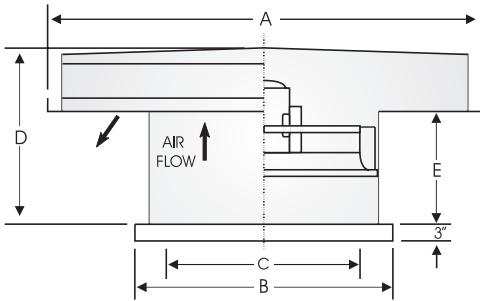

Model HREB-C Belt Drive
(Hoods on 42" - 60" ship KD) (2)
Specify assembled if required



Model HRED-C Direct Drive
(Hoods on 42" - 60" ship KD) (2)
Specify assembled if required

| MODEL HREB-C HRED-C | A SQ. O.D. HOOD (2) | B I.D. CURB CAP | C MIN I.D. OPENING | D HEIGHT | E STACK | PREFAB CURB O.D. | METAL GAUGES (1) | | | AVG. WT. |
|---------------------------|---------------------------|-----------------------|--------------------------|-------------|------------|---------------------|--------------------|-------|-------------|-------------|
| | | | | | | | CROWN/SIDE HOOD | STACK | CURB CAP | |
| 24 | 58 | 35 | 30 | 44 | 23 | 33-1/4 | 18/18 | 18 | 16 | 425 |
| 30 | 66 | 41 | 36 | 44 | 23 | 39-1/4 | 18/18 | 18 | 16 | 550 |
| 36 | 78 | 47 | 42 | 44 | 23 | 45-1/4 | 18/18 | 18 | 16 | 700 |
| 42 | 87 | 53 | 48 | 51 | 30 | 51-1/4 | 18/16 | 16 | 16 | 800 |
| 48 | 99 | 59 | 54 | 51 | 30 | 57-1/4 | 18/16 | 16 | 14 | 1100 |
| 54 | 111 | 65 | 60 | 51 | 30 | 63-1/4 | 18/16 | 16 | 14 | 1300 |
| 60 | 111 or 123 | 71 | 66 | 51 | 30 | 69-1/4 | 18/16 | 16 | 14 | 1550 |

- All materials are G90 galvanized steel.
- Hoods for fan sizes 24-36" ship assembled. Hoods for fan sizes 42-60" ship KD unless ordered factory assembled. Assembled 123" hoods must ship by double drop deck flat bed truck. This will affect normal freight rates. (123" hoods for 15hp - non catalog performance.)
- Hoods will hinge and front panel is removable for access to fan and optional damper.
- Propellers are 2, 3, 4, or 6-bladed adjustable pitch, air-foil aluminum (Fixed pitch steel and Aluminum are also available).
- Dampers mount on accessory flanges inside curbs or in the duct due to space restrictions.
- Delay switch required on models 10HP and larger with motorized damper (optional).

| FAN SPECIFICATIONS | | | | | | | | | MOTOR SPECIFICATIONS | | | | |
|--------------------|------|-----------|-----|-----|----|---------|-----|-------|----------------------|-------|-------|-------|------|
| Line | Qty. | Model No. | Tag | CFM | SP | Fan RPM | BHP | Sones | HP | Volts | Phase | Hertz | Encl |
| 1 | | | | | | | | | | | | | |
| 2 | | | | | | | | | | | | | |
| 3 | | | | | | | | | | | | | |
| 4 | | | | | | | | | | | | | |
| 5 | | | | | | | | | | | | | |

| ACCESSORY ITEMS | | | | | ACCESSORY ITEMS | | | | |
|-----------------|---|---|---|---|-----------------|---|---|---|---|
| 1 | 2 | 3 | 4 | 5 | 1 | 2 | 3 | 4 | 5 |
| | | | | | | | | | |
| | | | | | | | | | |
| | | | | | | | | | |
| | | | | | | | | | |

Project: _____ Submitted: _____
 Customer: _____ Approved: _____
 Location: _____