

MODEL GED/GSD DIRECT DRIVE SIDEWALL PROPELLER FAN WITH INTEGRAL OSHA GUARD



6393 Powers Avenue
Jacksonville, Florida 32217-2298
P: 800.961.7370 / F: 800.961.7379
www.solerpalau-usa.com

STANDARD CONSTRUCTION FEATURES

- Galvanized steel G90 panel assembly.
- Statically and dynamically balanced aluminum blades.
- Integral OSHA approved motor side guard.
- One piece spun venturi for maximum efficiency.
- Prepunched mounting holes for easy installation.
- Unit suitable for all-angle construction.
- cULus Listed - Standard 705 (optional)



Standard 705 (optional)

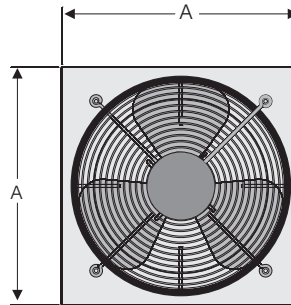

REAR VIEW

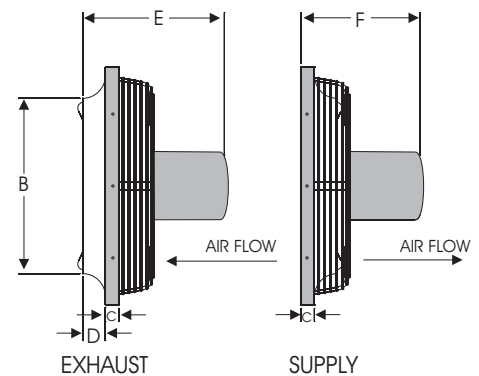

EXHAUST

SUPPLY

| GED/GSD Size | Dimensions (in.) | | | | | | Avg. Ship Wt. (lbs.) |
|--------------|------------------|--------|---|---|----|----|----------------------|
| | A | B | C | D | E* | F* | |
| 10 | 16 | 10-1/2 | 1 | 2 | 11 | 9 | 30 |
| 12 | 16 | 12-1/2 | 1 | 2 | 14 | 12 | 30 |
| 14 | 20 | 14-1/2 | 1 | 2 | 14 | 12 | 34 |
| 16 | 20 | 16-1/2 | 1 | 2 | 14 | 12 | 37 |
| 18 | 24 | 18-1/2 | 1 | 2 | 15 | 13 | 45 |
| 20 | 24 | 20-1/2 | 1 | 2 | 15 | 13 | 50 |

- A. Outside dimension of square panel.
- B. Diameter of venturi.
- C. Width of flange, 1" for all models.
- D. Depth of venturi, 2" for all models.
- E. Depth of fan (exhaust).
- F. Depth of fan (supply).

* Varies with motor selection.

| FAN SPECIFICATIONS | | | | | | | | | MOTOR SPECIFICATIONS | | | | |
|--------------------|------|-----------|-----|-----|----|---------|-----|-------|----------------------|-------|-------|-------|------|
| Line | Qty. | Model No. | Tag | CFM | SP | Fan RPM | BHP | Sones | HP | Volts | Phase | Hertz | Encl |
| 1 | | | | | | | | | | | | | |
| 2 | | | | | | | | | | | | | |
| 3 | | | | | | | | | | | | | |
| 4 | | | | | | | | | | | | | |
| 5 | | | | | | | | | | | | | |

| ACCESSORY ITEMS | | | | | ACCESSORY ITEMS | | | | |
|-----------------|---|---|---|---|-----------------|---|---|---|---|
| 1 | 2 | 3 | 4 | 5 | 1 | 2 | 3 | 4 | 5 |
| | | | | | | | | | |
| | | | | | | | | | |
| | | | | | | | | | |
| | | | | | | | | | |

| | |
|-----------------|------------------|
| Project: _____ | Submitted: _____ |
| Customer: _____ | Approved: _____ |
| Location: _____ | |

MODEL DFE/DFS DIRECT DRIVE SIDEWALL PROPELLER FAN



6393 Powers Avenue
Jacksonville, Florida 32217-2298
P: 800.961.7370 / F: 800.961.7379
www.solerpalau-usa.com

Soler&Palau
Ventilation Group

STANDARD CONSTRUCTION FEATURES

- Galvanized steel G90 panel assembly.
- Welded schedule 40 galvanized pipe support structure.
- Statically and dynamically balanced aluminum blades.
- Precision spun orifice for smooth performance.
- Prepunched mounting holes for easy installation.
- Permanently lubricated sealed ball bearing motors.
- Unit suitable for all-angle construction.

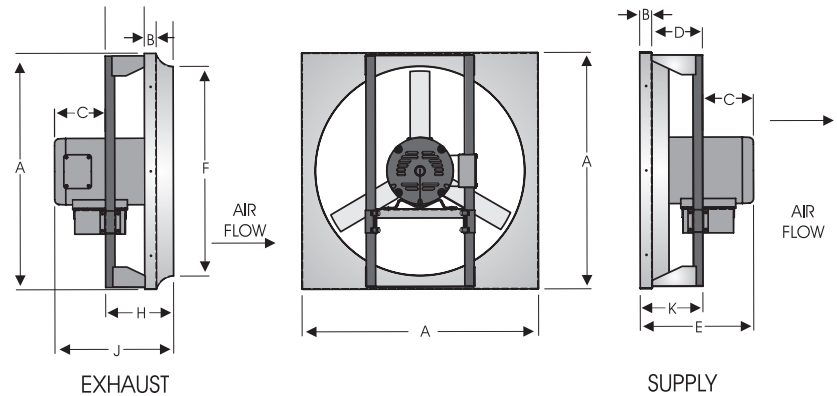

| DFE/DFS Size | Dimensions (in.) | | | | | | | | | | | Avg. Ship Wt. (lbs.) |
|--------------|------------------|---|----|---|----|--------|---|----|---|----|----|----------------------|
| | A | B | C* | D | E* | F | G | H | I | J* | K | |
| 10 | 16 | 1 | 6 | 6 | 11 | 10-1/2 | 2 | 8 | 5 | 14 | 7 | 30 |
| 12 | 16 | 1 | 6 | 6 | 11 | 12-1/2 | 2 | 8 | 5 | 14 | 7 | 30 |
| 16 | 20 | 1 | 6 | 6 | 12 | 16-1/2 | 2 | 8 | 5 | 14 | 7 | 37 |
| 18 | 24 | 1 | 6 | 6 | 12 | 18-1/2 | 2 | 8 | 5 | 14 | 7 | 45 |
| 20 | 24 | 1 | 7 | 6 | 12 | 20-1/2 | 2 | 8 | 5 | 15 | 7 | 50 |
| 24 | 30 | 2 | 10 | 9 | 21 | 25 | 3 | 10 | 4 | 20 | 11 | 70 |
| 30 | 36 | 2 | 10 | 9 | 21 | 31 | 3 | 10 | 4 | 20 | 11 | 100 |

- A. Outside dimension of square panel.
- B. Width of flange.
- C. Depth of motor beyond support structure.*
- D. Depth of support structure - supply.
- E. Depth of fan - supply.*
- F. Diameter of venturi.
- G. Depth of venturi.
- H. Depth of panel and support structure - exhaust.
- I. Depth of support structure - exhaust.
- J. Depth of fan - exhaust.*
- K. Depth of panel and support structure - supply.
- * Varies with motor selection

| FAN SPECIFICATIONS | | | | | | | | | | MOTOR SPECIFICATIONS | | | | |
|--------------------|------|-----------|-----|-----|----|---------|-----|-------|----|----------------------|-------|-------|------|--|
| Line | Qty. | Model No. | Tag | CFM | SP | Fan RPM | BHP | Sones | HP | Volts | Phase | Hertz | Encl | |
| 1 | | | | | | | | | | | | | | |
| 2 | | | | | | | | | | | | | | |
| 3 | | | | | | | | | | | | | | |
| 4 | | | | | | | | | | | | | | |
| 5 | | | | | | | | | | | | | | |

| ACCESSORY ITEMS | 1 | 2 | 3 | 4 | 5 | ACCESSORY ITEMS | 1 | 2 | 3 | 4 | 5 |
|-----------------|---|---|---|---|---|-----------------|---|---|---|---|---|
| | | | | | | | | | | | |
| | | | | | | | | | | | |
| | | | | | | | | | | | |
| | | | | | | | | | | | |

Project: _____ Submitted: _____
 Customer: _____ Approved: _____
 Location: _____

