

**MODEL DB - HWL
BELT DRIVE CENTRIFUGAL ROOF EXHAUSTER
CERTIFIED HIGH WIND LOAD (HWL) CONSTRUCTION OPTION**



6393 Powers Avenue
Jacksonville, Florida 32217-2298
P: 800.961.7370 / F: 800.961.7379
www.solerpalau-usa.com

Soler&Palau
Ventilation Group



UL Standard 705
(optional)



STANDARD CONSTRUCTION FEATURES

- High strength internal support and external stainless steel wire tie downs.
- High efficiency, dynamically balanced non-stalling backward inclined wheel.
- Motor and drive assembly isolated from air stream and external environment for extended life.
- 1 or 3Ph ODP, TEFC, Explosion Proof or Premium Efficiency motors available.
- **Ideally suited for coastline installations** includes stainless steel fasteners and non-corrosive materials.
- NEMA disconnect switches available.

SIZE	DIMENSIONS (IN.)						AVG. SHIP WT. LBS.
	A	B	C	D	E	F	
6-8-9	20 1/2	17 1/2	16 1/2	3 1/2	16 1/8	1 3/4	80
11	28 3/8	23	24	3 1/2	22 1/2	2	130
12	28 3/8	23	24	3 1/2	22 1/2	2	130
14	28 3/8	23	24	3 1/2	22 1/2	2	140
16	32 1/4	24	24	6	26 1/4	2 1/2	145
18	32 1/4	24	29 1/2	4 1/2	26 1/4	2 1/2	160
20	36 3/4	24 1/2	29 1/2	4 1/2	26 1/4	2 1/2	215
24	41 1/4	26 1/2	35 3/4	8 1/2	30	2 1/2	290
30	58 3/8	37	42 1/2	5 1/2	41	2 1/2	465
36	58 3/8	37	42 1/2	10	41	2 1/2	475
42	73	40 1/2	55	10	54 5/8	2 1/2	700
48	73	40 1/2	55	13	54 5/8	2 1/2	830

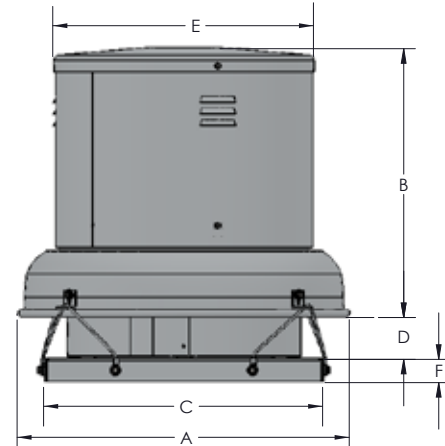

A - Skirt OD (Dia). D - Skirt height.
B - Height. E - Motor cover OD (Dia).
C - Curb cap OD. F - Curb cap flange.

DIMENSIONS REPRESENT GENERAL CONSTRUCTION AND MAY VARY SLIGHTLY. CONTACT FACTORY FOR CERTIFIED DRAWINGS.

NOTES:

1. MODEL DB HAS BEEN SUCCESSFULLY TESTED IN ACCORDANCE WITH MIAMI DADE TEST PROTOCOL TAS-201 (LARGE MISSILE IMPACT); TAS-202 (STATIC LOADING); TAS-203 (CYCLIC WIND PRESSURE LOADING).
2. ROOF STRUCTURE MUST BE DESIGNED TO WITHSTAND THE WEIGHT AND LOADING TRANSMITTED BY ROOF TOP FANS. FASTENERS SHALL BE AS SPECIFIED AND INSTALLED AS DETAILED.
3. DESIGN TESTING AND INSTALLATION CONFORMS TO 2004 FLORIDA BUILDING CODE AND ITS 2005 AND 2006 SUPPLEMENTS.
4. CERTIFIED HWL FAN CURBS MUST BE ANCHORED TO ROOF FRAMING MEMBERS AND NOT TO THE ROOFING SYSTEM.

FAN SPECIFICATIONS									MOTOR SPECIFICATIONS				
Line	Qty.	Model No.	Tag	CFM	SP	Fan RPM	BHP	Sones	HP	Volts	Phase	Hertz	Encl
1													
2													
3													
4													
5													

ACCESSORY ITEMS	1	2	3	4	5	ACCESSORY ITEMS	1	2	3	4	5
<input type="checkbox"/>						<input type="checkbox"/>					
<input type="checkbox"/>						<input type="checkbox"/>					
<input type="checkbox"/>						<input type="checkbox"/>					
<input type="checkbox"/>						<input type="checkbox"/>					
<input type="checkbox"/>						<input type="checkbox"/>					