

MODEL BDT BELT DRIVEN TUBEAXIAL DUCT FANS



6393 Powers Avenue
Jacksonville, Florida 32217-2298
P: 800.961.7370 / F: 800.961.7379
www.solerpalau-usa.com

STANDARD FEATURES

- Housing - Heavy-gauge rolled steel, continuously welded.
- Adjustable motor base.
- Pillow block ball bearings with lube fittings.
- L50-200,000 hours average bearing life.
- Propellers available in steel or aluminum.
- Motor, drives and bearings out of the airstream.
- Adjustable sheaves - thru 3HP
- Prepunched - welded flange rings.
- cULus Listed - Standard 705 (optional).

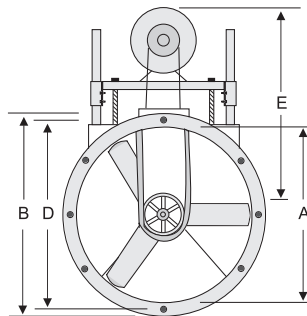

Front View

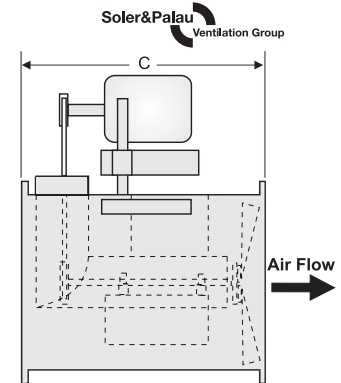

Side View

Model No.	Housings			Flange Hole Center D	E (Max)	Holes		Max Motor Frame	Steel Housing Gauges	Avg. Ship Wt. (Lbs)
	I.D. A	O.D. B	Length C			Dia.	#			
12	13 1/32	16 3/16	15	15	16	1/2	8	145T	14	75
16	17 1/32	20 3/16	19	19	19	1/2	8	145T	14	85
18	19 1/32	22 3/16	19	20 3/4	21	1/2	8	145T	14	110
21	22 1/32	25 3/16	19	23 3/4	23	1/2	8	182T	14	125
24	25 1/8	29 1/8	30	27 1/8	33	1/2	8	215T	12	180
30	31 1/8	35 1/8	30	33 1/8	36	1/2	8	215T	12	250
36	37 1/8	41 1/8	30	39 5/8	39	1/2	8	215T	12	280
42	43 1/8	47 1/8	32	45 1/8	42	1/2	8	254T	12	390
48	49 1/8	53 1/8	32	51 1/5	45	1/2	8	254T	10	500
54	55 1/8	59 1/8	32	57 1/8	48	1/2	8	256T	10	800

NOTE: All dimensions shown are in inches.

FAN SPECIFICATIONS									MOTOR SPECIFICATIONS				
Line	Qty.	Model No.	Tag	CFM	SP	Fan RPM	BHP	Sones	HP	Volts	Phase	Hertz	Encl
1													
2													
3													
4													
5													

ACCESSORY ITEMS					1	2	3	4	5	ACCESSORY ITEMS					1	2	3	4	5

