

MODEL CWD DIRECT DRIVE CENTRIFUGAL SIDEWALL EXHAUSTER



6393 Powers Avenue
Jacksonville, Florida 32217-2298
P: 800.961.7370 / F: 800.961.7379
www.solerpalau-usa.com

Soler&Palau
Ventilation Group

STANDARD FEATURES

- Heavy-gauge, corrosion free, spun aluminum housing and all stainless steel fastenings.
- Permanently lubricated motor, mounted in compartment sealed from exhaust airstream.
- Exclusive steel U-spring suspension for permanent maximum vibration isolation (except 141 and 161).
- Nonoverloading all aluminum wheel dynamically and statically balanced.
- Internal, watertight, aluminum wiring post provided for electrical conduit.

NOTE: For round duct connection to unit without damper, cut a circular hole in the wall to dimension E.

NOTE: Disconnect switch ships loose for field installation and wiring.

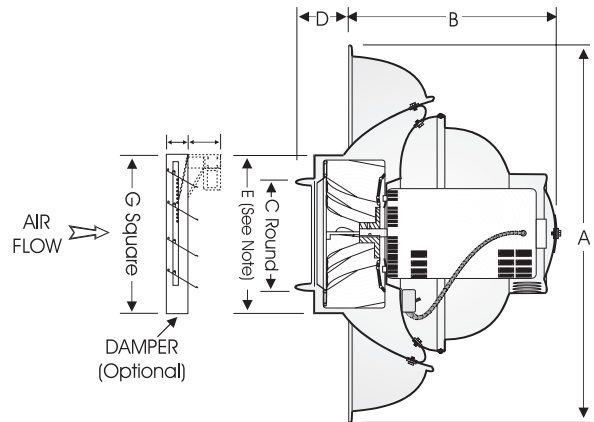

MODEL NO.	DIMENSIONS (IN)						AVG. SHIP WT. (LBS)
	A	B	C	D	E	G	
070A	15	8	5 15/16	1 1/2	8	8	15
080A	20	9	9 15/16	2	12	11	25
090A - 101A	26	13 1/2	11 15/16	3	15	14	37
110A - 121A	30	15 1/2	13 15/16	3	17 1/2	14	80
141A - 161A	36	16 1/2	17 15/16	4	22	18	84



FAN SPECIFICATIONS									MOTOR SPECIFICATIONS				
Line	Qty.	Model No.	Tag	CFM	SP	Fan RPM	BHP	Sones	HP	Volts	Phase	Hertz	Encl
1													
2													
3													
4													
5													

ACCESSORY ITEMS	1	2	3	4	5	ACCESSORY ITEMS	1	2	3	4	5
<input type="checkbox"/>						<input type="checkbox"/>					
<input type="checkbox"/>						<input type="checkbox"/>					
<input type="checkbox"/>						<input type="checkbox"/>					
<input type="checkbox"/>						<input type="checkbox"/>					
<input type="checkbox"/>						<input type="checkbox"/>					

Project: _____ Submitted: _____
 Customer: _____ Approved: _____
 Location: _____