

# MODELS UBB & UBX

## UPBLAST PROPELLER ROOF EXHAUSTERS

### BELT AND DIRECT DRIVE



### **MODEL FEATURES**

- Exhaust air up to 78,000 CFM in static pressure applications up to 1/2" w.g.
- Straight-through air flow design results in maximum exhaust efficiency
- Belt drives permit easy performance adjustments when needed
- Direct drive units have low sound levels and quiet operation
- cULus 705 Listed

---

### **MODEL OPTIONS**

<b>MODEL NAME</b>	<b>DESCRIPTION</b>
<b>UBB</b>	Belt Drive Upblast Propeller Roof Exhauster
<b>UBX</b>	Direct Drive Upblast Propeller Roof Exhauster

---

### **MODEL OVERVIEW**

Models UBB and UBX are high capacity roof mounted exhausters rated from 5,900 to 78,000 CFM. They are general ventilation units designed to economically remove large volumes of air, fumes and vapors from commercial and industrial buildings such as warehouses, manufacturing and assembly plants, distribution centers, chemical plants, foundries and paper mills.

Straight-through air flow design results in maximum exhaust efficiency. During operation, high air flow velocity opens butterfly dampers and prevents rain or snow from entering. Dampers close and cover the venturi opening when unit is not in use.

The roof mounted location eliminates interference with processes and equipment inside the building. It also permits locating the exhauster over a source of heated or contaminated air, allowing direct upward venting to the outside, unlike wall mounted exhausters which may move contaminated air through adjacent work spaces.

Belt drive units usually operate more quietly and afford easier performance adjustments, while direct drive models require less maintenance.

**2 year fan housing warranty, 1 year motor warranty**



## CONSTRUCTION FEATURES AND OPTIONS

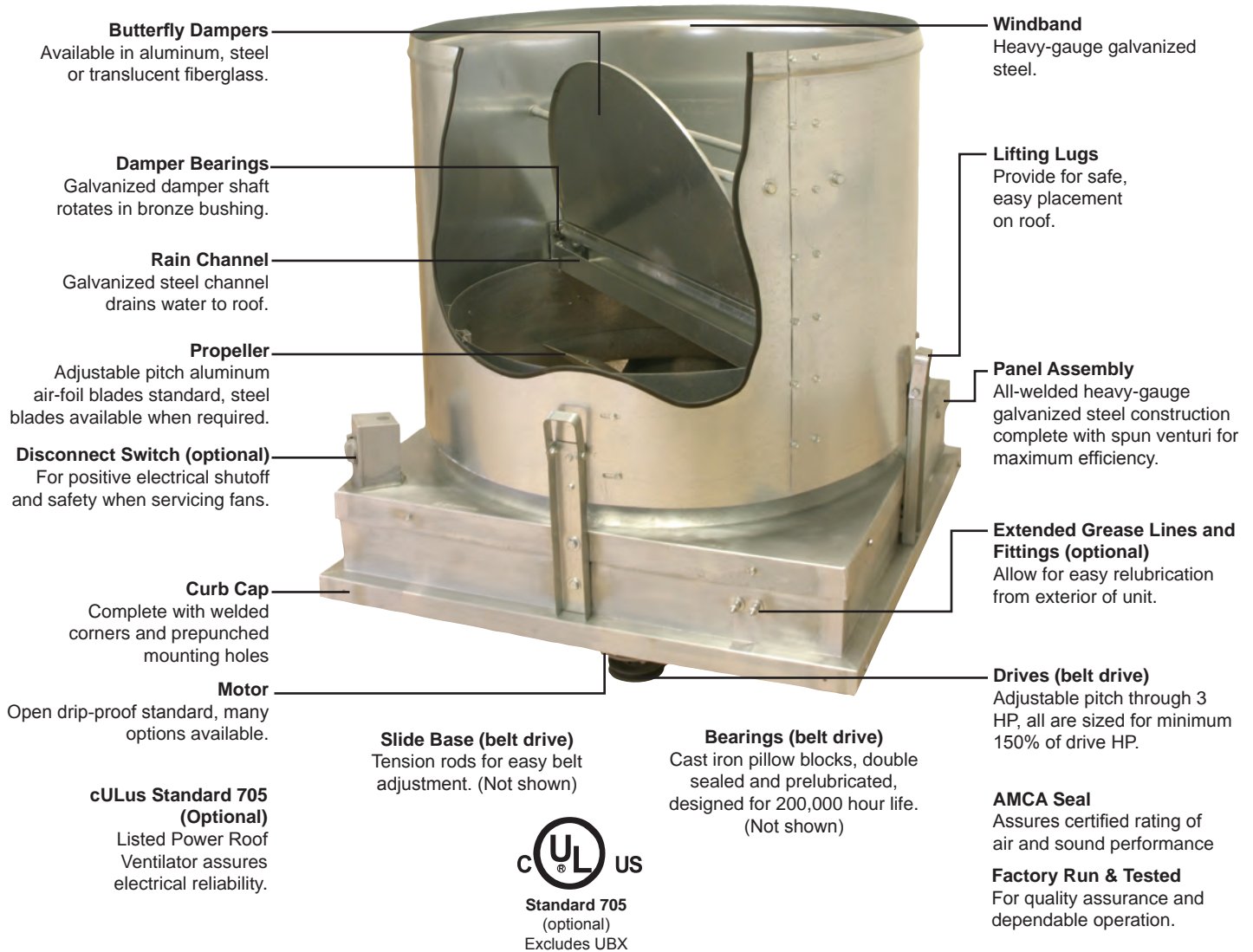

**Butterfly Dampers**  
Available in aluminum, steel or translucent fiberglass.

**Windband**  
Heavy-gauge galvanized steel.

**Damper Bearings**  
Galvanized damper shaft rotates in bronze bushing.

**Lifting Lugs**  
Provide for safe, easy placement on roof.

**Rain Channel**  
Galvanized steel channel drains water to roof.

**Propeller**  
Adjustable pitch aluminum air-foil blades standard, steel blades available when required.

**Panel Assembly**  
All-welded heavy-gauge galvanized steel construction complete with spun venturi for maximum efficiency.

**Disconnect Switch (optional)**  
For positive electrical shutoff and safety when servicing fans.

**Extended Grease Lines and Fittings (optional)**  
Allow for easy relubrication from exterior of unit.

**Curb Cap**  
Complete with welded corners and prepunched mounting holes

**Motor**  
Open drip-proof standard, many options available.

**Slide Base (belt drive)**  
Tension rods for easy belt adjustment. (Not shown)

**Bearings (belt drive)**  
Cast iron pillow blocks, double sealed and prelubricated, designed for 200,000 hour life. (Not shown)

**Drives (belt drive)**  
Adjustable pitch through 3 HP, all are sized for minimum 150% of drive HP.

**cULus Standard 705 (Optional)**  
Listed Power Roof Ventilator assures electrical reliability.



**AMCA Seal**  
Assures certified rating of air and sound performance

**Factory Run & Tested**  
For quality assurance and dependable operation.



## **CONSTRUCTION/SPECIFICATION CHECKLIST**

### **Panel Assembly**

- Heavy-gauge G90 galvanized steel panel on all sizes.
- One piece venturi for maximum efficiency.
- All welded support structure of schedule 40 galvanized pipe.
- Motor/bearing plates of minimum 10 gauge galvanized steel.

### **Windband/Butterfly Dampers**

- Heavy-gauge galvanized steel windband.
- Steel dampers standard (except on sizes 48-72).
- Translucent fiberglass dampers available on all sizes (standard on sizes 48-72).
- Galvanized rain channel drains water from damper area to roof.
- Galvanized damper shaft rotates in bronze bushing.

### **Propeller**

- Two, three, four or six airfoil aluminum blades.
- Steel hub plate with steel taper lock bushing.
- Adjustable pitch for optimum efficiency.
- Die formed steel blades are optional where required.

### **Drives (belt drive models)**

- Sized for minimum 150% of drive horsepower.
- Single belt adjustable pitch sheaves through 3HP.
- Two belt fixed pitch sheaves through 10HP.
- Three belt fixed pitch sheaves on 15 HP.
- Adjustable pitch sheaves are optional above 3HP.
- Adjustable tension rods for belt adjustment.
- Nonstatic oil resistant v-belts.
- Keyed, turned, ground and polished shafts.

### **Bearings**

- Bearings designed for minimum 200,000 hour life, L50.
- Cast iron self-aligning pillow block ball bearings.
- Bearings are sealed, prelubricated with relube fittings.

### **Motors**

- Brands are nationally recognized and locally serviced.
- Open drip-proof construction is standard.
- High-efficiency, explosion proof, totally enclosed fan cooled (TEFC) and corrosion duty motors can be specified.

### **Certifications**

- AMCA Air & Sound Licensed.
- cULus 705 listed power roof ventilator assures electrical reliability (optional). Excludes UBX.



## **OPTIONS/ACCESSORIES**

**Roof Curb:** Prefabricated heavy-gauge galvanized steel, welded construction, 12" high with 1-1/2" wood nailer. Options include burglar bars, single and double pitch construction, and additional curb heights.



**Disconnect Switch:** Nonfused safety disconnects are available for all motor sizes in rain-tight or open enclosures.

**Magnetic Latches:** Help reduce damper chatter when the units are not in operation.

**Heat/Smoke Vent:** Opens damper doors when temperature exceeds 165°F. Allows heat and smoke to escape building without use of fan power.

**Outlet Guard:** 1/2" x 1" wire mesh guard will prevent birds and other objects from entering fan.

**Extended Grease Lines:** Extended grease lines allow fan bearings to be relubricated from the exterior.

**Aluminum Construction:** Optional aluminum construction available on windbands, curb caps, panel and blades.

**Special Coatings:** Powered roof exhausters often require special coatings for protective and decorative purposes. Available coatings include: Synthetic Resin, Epoxy, and Heresite (air-dried phenolic). Contact your representative or the factory for more information on available coatings and colors.



## PERFORMANCE

### UBB - Belt Drive

Model UBB	CFM @ Static Pressure					HP	RPM	Blades / Pitch	Max. BHP	Sones @ 5 ft.
	0	1/8	1/4	3/8	1/2					
24	7180	6500	5720	4800	-	3/4	1210	3	0.82	22
	7920	7300	6610	5880	-	1	1335	3	1.11	25
	9080	8550	7960	7340	6600	1-1/2	1525	3	1.65	32
	10000	9500	9000	8450	7900	2	1680	3	2.21	37
30	9398	8323	7039	5381	3254	1	960	3	1.14	25
	10670	9740	8685	7436	5389	1-1/2	1090	3	1.67	33
	11747	10910	9987	8941	7716	2	1200	3	2.23	39
	13411	12686	11907	11059	10118	3	1370	3	3.33	46
36	13279	11086	-	-	-	1	700	3	1.26	21
	15081	13170	11062	-	-	1-1/2	795	3	1.85	27
	16978	15289	13502	11351	-	2	895	3	2.64	32
	19349	17872	16345	14714	12675	3	1020	3	3.91	37
42	19800	16800	-	-	-	1-1/2	640	3	1.68	25
	22100	19300	16000	-	-	2	710	3	2.30	30
	25000	22600	19800	16800	-	3	805	3	3.35	37
	29700	27600	25300	23000	20300	5	950	3	5.51	45
48	26300	22500	17600	-	-	2	575	3	2.31	25
	30200	26700	22700	17800	-	3	655	3	3.41	34
	35500	32500	29400	25800	21500	5	770	3	5.54	45
	40600	38000	35300	32600	29300	7-1/2	880	3	8.27	54
	44800	42500	40100	37500	34800	10	970	3	11.07	60
54	35000	30200	24200	-	-	3	545	3	3.39	28
	41200	36900	32500	27000	-	5	640	3	5.49	40
	47200	43700	39800	35700	30900	7-1/2	735	3	8.32	50
	51800	48500	45000	41300	37400	10	805	3	10.92	58
60	48200	42600	36000	27800	-	5	550	3	5.50	38
	55200	50300	45000	38800	-	7-1/2	630	3	8.27	51
	61000	56600	51900	46700	40700	10	695	3	11.10	60
72	61700	51900	40500	-	-	5	410	3	5.47	31
	70700	62300	53200	-	-	7-1/2	470	3	8.24	42
	70800	62800	52800	53300	-	10	520	3	11.15	50

Performance shown is for installation type A: free inlet, free outlet Power Rating (BHP) does not include transmission losses.

Performance ratings do not include the effects of appurtenances in the airstream.

The sound ratings shown are loudness values in fan sones at 1.5 m (5 ft) in a hemispherical free field calculated per AMCA International Standard 301. Values shown are for: Installation Type A: free inlet hemispherical sone levels. The AMCA ratings sound seal applies to sone ratings only.



### UBX - Direct Drive

Model UBX	CFM @ Static Pressure					HP	RPM	Blades / Pitch	Max. BHP	Sones @ 5 ft.
	0	1/8	1/4	3/8	1/2					
24	5900	5200	-	-	-	1/2	870	6	0.54	15
	6300	5400	-	-	-	1/2	1160	2	0.55	18
	6900	6300	5600	-	-	3/4	1160	3	0.81	22
	7400	6900	6400	5700	-	1	1160	6	1.10	23
	6600	6100	5500	4900	-	3/4	1750	2	0.82	30
	7500	7100	6500	5900	5200	1	1750	2	1.09	32
	9100	8500	7900	7300	6600	1-1/2	1750	2	1.63	36
	7700	7200	6800	6300	5800	2	1750	3	1.86	42
	11200	10800	10400	10000	9700	3	1750	4	3.30	54
	10100	8700	-	-	-	3/4	870	4	0.83	21
30	10600	9400	7900	-	-	1	870	6	1.11	22
	9800	8500	-	-	-	3/4	1160	2	0.81	27
	10900	9600	8300	-	-	1	1160	2	1.08	30
	12300	11300	10100	8600	-	1-1/2	1160	3	1.62	34
	13800	12900	11900	10700	-	2	1160	4	2.20	37
	10800	10000	9100	8200	9100	1-1/2	1750	2	1.65	44
	12800	12000	11200	10400	9500	2	1750	2	2.19	48
	15800	15000	14100	13200	12300	3	1750	2	3.30	58
	18600	17900	17200	16500	15600	5	1750	3	5.51	70



S&P USA Ventilation Systems, LLC., Div. of Soler & Palau Ventilation Group, certifies that the Models UBB and UBX shown herein are licensed to bear the AMCA Seal. The ratings shown are based on test and procedures performed in accordance with AMCA Publication 211 and AMCA Publication 311 and comply with the requirement of the AMCA Certified Ratings Program.

Performance certified is for installation type A - free inlet, free outlet. Performance ratings do not include the effects of appurtenances in the airstream. The sound ratings shown are loudness values in fan sones @ 5' (1.5m) in a hemispherical free field calculated per AMCA Standard 301. Values shown are for: Installation Type A: free inlet hemispherical sone levels Speed (RPM) shown is nominal. Performance is based on actual speed of test.



## UBX - Direct Drive (Cont.)

Model UBX	CFM @ Static Pressure					HP	RPM	Blades / Pitch	Max BHP	Sones @ 5 ft.
	0	1/8	1/4	3/8	1/2					
36	14200	12000	-	-	-	1	870	2	1.10	23
	15900	14300	12500	-	-	1-1/2	870	4	1.64	25
	17700	16200	14300	12400	-	2	870	4	2.17	33
	18900	17700	16300	14800	12700	3	870	6	3.24	36
	15700	14200	12400	-	-	1-1/2	1160	2	1.65	36
	17600	16000	14300	12200	-	2	1160	2	2.19	38
	20000	18400	16700	14900	12700	3	1160	2	3.32	42
	23000	22000	20700	19400	18000	5	1160	4	5.40	58
	17900	16700	15500	14300	13100	3	1750	2	3.26	75
	23700	22800	21700	20700	19500	5	1750	2	5.60	77
27400	26500	25300	24200	23100	7-1/2	1750	2	8.20	78	
42	20400	17800	14000	-	-	1-1/2	870	2	1.60	28
	22800	19800	16700	-	-	2	870	2	2.24	31
	25400	23500	21400	19100	15900	3	870	4	3.27	33
	20800	18700	16200	13300	-	2	1160	2	2.23	42
	25200	23200	20900	18300	15000	3	1160	2	3.18	44
	30800	28300	26000	23600	21500	5	1160	2	5.58	50
	34600	33300	31800	30200	28500	7-1/2	1160	4	8.20	58
	32800	30000	30000	28500	-	7-1/2	1750	2	8.15	92
48	26200	22800	19700	-	-	2	870	2	2.17	33
	30800	27200	23200	18600	-	3	870	2	3.35	38
	36300	33500	30500	27000	21500	5	870	3	5.60	42
	40300	37700	34800	31800	27600	7-1/2	870	3	8.27	48
	27900	25000	22100	19700	-	3	1160	2	3.40	49
	35900	33500	31000	28900	24300	5	1160	2	5.55	57
	41800	39300	36500	33900	30700	7-1/2	1160	2	8.23	67
	45800	43000	40200	37400	34500	10	1160	2	11.10	69
54	35700	31600	26700	19400	-	3	870	2	3.28	47
	43900	39200	34600	29300	21900	5	870	2	5.55	54
	48900	45500	41900	38100	33300	7-1/2	870	3	8.32	59
	38500	35200	31800	28300	25000	5	1160	2	5.55	68
	49200	46400	43000	39700	35700	7-1/2	1160	2	8.40	75
55600	52500	49200	46400	41900	10	1160	2	11.20	77	
60	57200	52600	47500	41800	35100	7-1/2	870	2	8.30	64
72	65500	59000	52000	44000	-	7-1/2	870	2	8.24	78

Performance certified is for installation type A - free inlet, free outlet. Performance ratings do not include the effects of appurtenances in the airstream. The sound ratings shown are loudness values in fan sones @ 5' (1.5m) in a hemispherical free field calculated per AMCA Standard 301. Values shown are for: Installation Type A: free inlet hemispherical sone levels Speed (RPM) shown is nominal. Performance is based on actual speed of test.



S&P USA Ventilation Systems, LLC., Div. of Soler & Palau Ventilation Group, certifies that the Models UBB and UBX shown herein are licensed to bear the AMCA Seal. The ratings shown are based on test and procedures performed in accordance with AMCA Publication 211 and AMCA Publication 311 and comply with the requirement of the AMCA Certified Ratings Program.



## DIMENSIONS

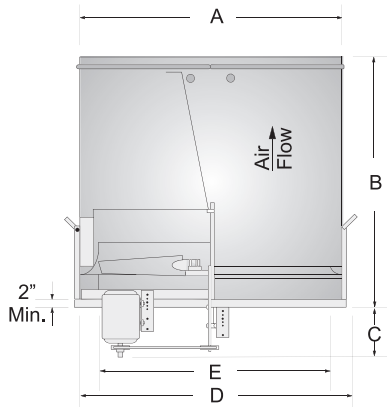

**Model UBB - Belt Drive**

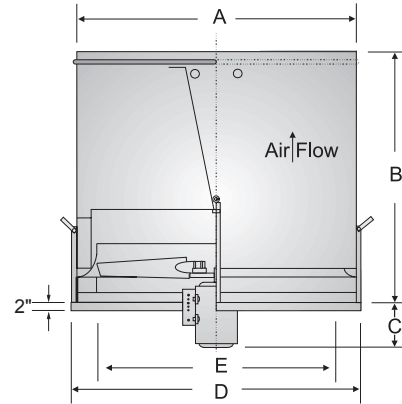

**Model UBX - Direct Drive**

Size	Dimensions (Inches)							Metal Gauges			Avg. Wt.
	A	B	C	D Sq.	E Sq.	F Sq.	G Sq.	Wind-band	Curb Cap	Fan Panel	
24	30	33	16	32	24	31	28	18	16	16	310
30	36	36	17	38	30	37	34	18	16	16	340
36	42	38	17	44	36	43	40	18	16	16	430
42	48	41	18	50	42	49	46	18	16	16	490
48	54	44	22	56	48	55	52	18	14	16	640
54	60	47	22	62	54	61	58	18	14	14	840
60	66	50	22	68	60	67	64	18	14	14	1000
72	80	56	31	82	72	81	78	18	12	12	1550

**A** - Outside dimension of windband.

**B** - Height of unit above curb cap.

**C** - Maximum depth of unit below top of curb, actual depth varies with motor size.

**D** - Inside dimension of square curb cap.

**E** - Minimum inside dimension of curb opening required for adequate clearance of fan frame.

**F** - Outside dimension of factory built pre-fab curb.

**G** - Recommended roof opening (inside dimension of factory built prefab curb.)