

TXB Centrifugal Roof Upblast Exhausters

Belt Drive

Catalog TXB01-July 2007



The World's Leading Producer of
Air Movement Products



Soler & Palau USA, Div. of Soler & Palau Ventilation Group, certifies that the Models TXB shown herein are licensed to bear the AMCA Seal. The ratings shown are based on test and procedures performed in accordance with AMCA Publication 211 and AMCA Publication 311 and comply with the requirement of the AMCA Certified Ratings Program.

Soler&Palau  Ventilation Group

COMMERCIAL PRODUCT LINE



Model TXB Belt Drive Centrifugal Upblast Roof Exhausters

Application

Model TXB belt drive fans are roof mounted centrifugal upblast exhausters rated from 250 to 35,000 CFM with static pressure capabilities to 3-1/4 inches. Soler & Palau USA offers the widest horsepower and CFM selection in the industry. All fans are factory test run for quality assurance. Check our Quickship Program for your rapid delivery requirements.

The TXB was designed with serviceability in mind. The motor compartment can be serviced through the removable top, or the motor housing can be removed by loosening four nuts. Soler & Palau USA's optional "Grease Grabber" is an inexpensive and easy solution to grease containment. The Grease Grabber media allows water to drain away while grease is contained.

Isolation of motor and drive components from the airstream and the high velocity vertical air discharge make the Model TXB ideally suited for the removal of dirty contaminated and/or high temperature air from processes and buildings. Typical applications include restaurant hoods and similar kitchen exhaust ventilation, fume and smoke removal, laboratory fume hood exhaust and chemical process exhaust.

All TXB fans are designed and manufactured for high performance and long life. Soler & Palau USA covers the TXB with a 5 year fan warranty and a 1 year motor warranty. TXB-UL762 units have a 1 year fan and motor warranty. Heavy-gauge materials are used throughout the TXB. The spun inlet and shroud design provide excellent air moving efficiencies. The motor brackets are heavy-gauge steel, and isolated from the unit to eliminate unwanted vibration and noise transmission. For companion direct drive upblast fans, see the Model TXD with it's complementing design. There is no finer centrifugal upblast made period.

Construction/Specification Checklist

Housing

- Curb cap with integral deep single piece spun inlet for efficient performance and prevention of leakage into ductwork.
- Heavy-gauge aluminum housing and curb cap for strength and rigidity. Curb cap is galvanized steel on all UL 762 units.
- Adjustable motor base for proper belt tension and ease of adjustment.
- Enclosed ventilated motor/drive compartment isolates motor and drives from exhaust air.
- Neoprene isolators for reduction of vibration and sound.
- The motor compartment housing easily removes with a minimum of tools for complete maintenance access.
- Water-tight conduit tube for easy electrical connection without having to wire through the breather tube.
- Birdscreen and disconnect are included on standard models (Disconnects not included on 2 speed and explosion proof units).
- Birdscreen not included on UL762 units.

Centrifugal Wheel

- Backward inclined for efficiency at higher static pressure.
- Nonoverloading for safe operation in ducted systems.
- Heavy aluminum hub for extra strength.
- Close running tolerance between inlet cone and wheel inlet for maximum efficiency.
- Statically and dynamically balanced for smooth quiet operation.

Motors

- Brands are nationally recognized and locally serviced.
- Single speed drip-proof motors are provided on standard models.
- Disconnect switch is standard with single speed motors.
- Welded motor brackets designed for maximum strength.

Drives

- Sized for minimum 150% of drive horse power.
- Machined cast iron adjustable motor pulleys.
- Adjustable base for belt tensioning.
- Nonstatic oil resistant V-Belts.

Bearings

- 5 year bearing warranty.
- Heavy-duty ball bearing type.
- Prelubricated and permanently sealed.
- Sized for a minimum L50 life in excess of 200,000 hours.

Certifications

- AMCA Air and Sound Licensed.
- cULus 705 Listed Power Roof Ventilator label assures electrical reliability.
- cULus 762 Listed for Restaurant Exhaust Appliance available for applications where required.
- cULus 705 and cULus 762 assure electrical reliability for Canadian use.
- cULus label must be specified when needed.
- NFPA - Model TXB is suitable for National Fire Protection Association installations. Contact factory for required accessories.

Options/Accessories

Roof Curb: Prefabricated heavy-gauge galvanized steel, welded construction, 12" high (other heights are also available) with 1-1/2" wood nailer. Assures perfect fit of exhauster to roof opening. Options include burglar bars, single or double pitch construction and hinged curbs for easy duct access.

Motor Operated Damper: Motor operated aluminum damper for positive closure against backdraft. (Not for UL 762 use).

Automatic Damper: Automatic aluminum damper for ease in installation and effective backdraft protection. (Not for UL 762 use).

Grease Grabber or Aluminum Grease Trough: Trap designed for fast and inexpensive replacement. Grease collects in a container for safe and sanitary disposal. Keeps roof clean with proper use.

Wall Mount Kit: Kit allows 8-24" fans to be wall mounted. Kit can be field installed or ordered assembled from the factory. See current submittal for details.

Special Coatings: Epoxy, Heresite and Eisenheiss are available when special coatings are required.

Birdscreen: Integral birdscreen provides protection from birds or other objects. Screen is horizontal with access to wheel provided.

Hinged Curb Cap: For easy access to ductwork.

Optimizer Selection Program

Please refer to Soler & Palau USA's Optimizer Program for fan curve, submittal information and other details of the TXB series and other Soler & Palau USA products. Contact your representative or factory for a copy. Visit Soler & Palau USA's website for additional information: www.solerpalau-usa.com.

Quickship Program

Most TXB Models and many optional accessories are available on the Quickship Program. This program provides rapid delivery of standard products so that tight project deadlines can be met and downtime on replacement work can be held to a minimum.

All specifications are subject to change without notice unless approved in submittal by Soler & Palau USA.

Model TXB

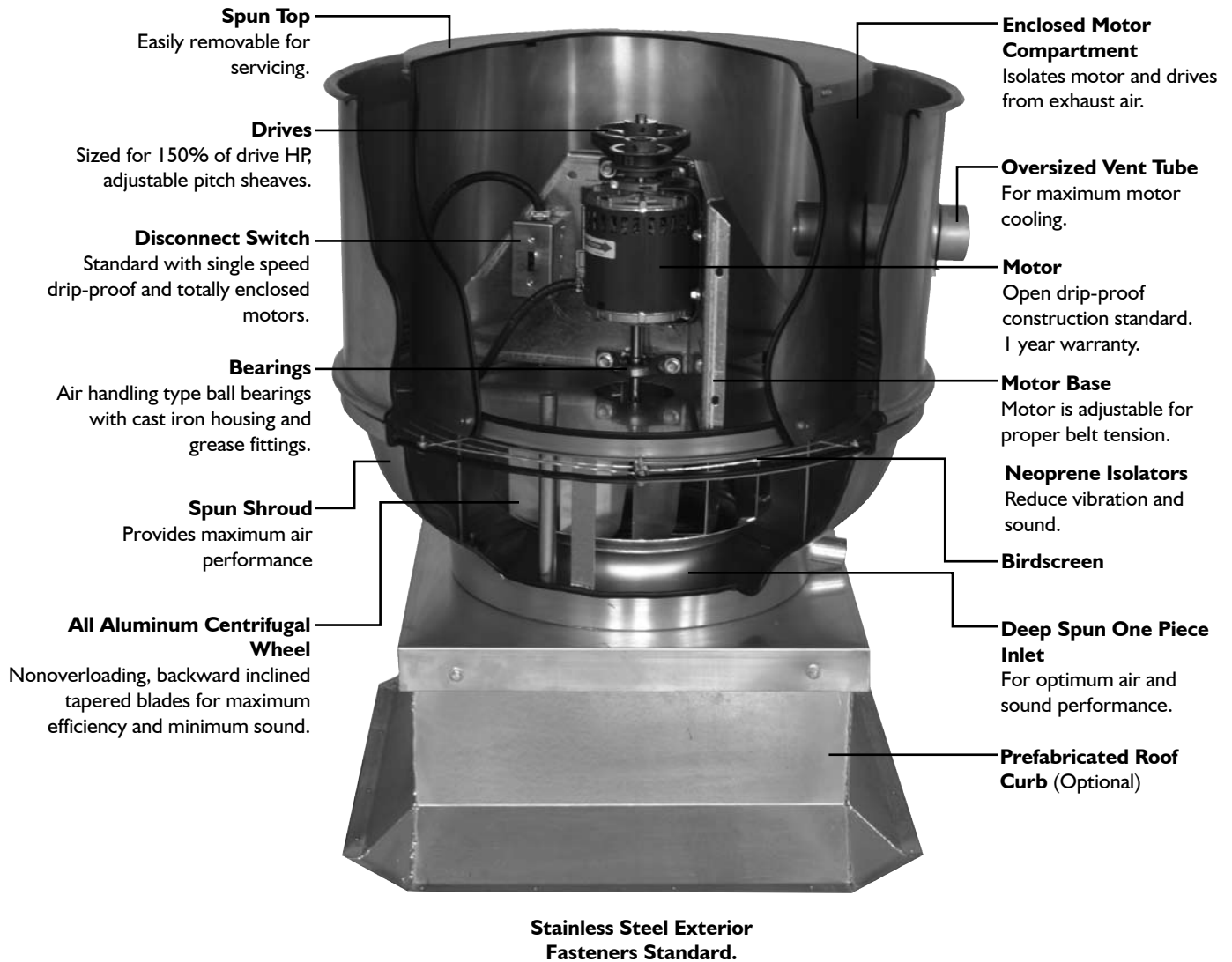

TYPICAL SPECIFICATIONS

Roof exhaust fan shall be centrifugal belt drive upblast type. Unit shall be constructed of aluminum for corrosion resistance, durability and appearance. Fan windband shall have a rolled bead edge for rigidity. Units shall have a deep venturi inlet to prevent snow and rain entry. All external fasteners shall be stainless steel.

Fan wheels shall be of the centrifugal backward inclined type, constructed of all aluminum and containing a matching inlet venturi for optimum unit performance. Wheels shall be statically and dynamically balanced.

Motor and drive assembly shall be isolated from unit to eliminate vibration and noise transmission.

Motor and wheel assemblies shall be removable as a complete module without complete disassembly of the unit for service and maintenance. Motors shall be mounted out of the exhaust airstream and cooled by air separate from the exhaust. A wiring conduit shall be provided to allow motor wiring and fan servicing without using the breather tube as a wiring path. Fan shafts shall be precision ground and polished. Shafts shall not be pressed onto bearings.

Bearings shall be of the one-piece, cast iron, pillow block type with relubrical zerk fittings. Bearings service shall be designed for a minimum L50 life in excess of 200,000 hours. Fan housing and drive assembly will have a 5 year warranty (UL762 unit has 1 year warranty).

Motors shall be from nationally recognized manufacturers and of the specified electrical power (volts/phase/Hz.) and enclosure type. Fans shall be AMCA licensed for Air and Sound performance.

Drive assembly shall be constructed of heavy-gauge galvanized steel and contain no welding. Drives shall be sized for a minimum of 150% of driven horsepower. Machined, cast iron motor sheaves shall be adjustable for final system balance.

Fans shall be Model TXB as manufactured by Soler & Palau USA, Jacksonville, Florida.



Model TXB-UL762 Restaurant Exhaust

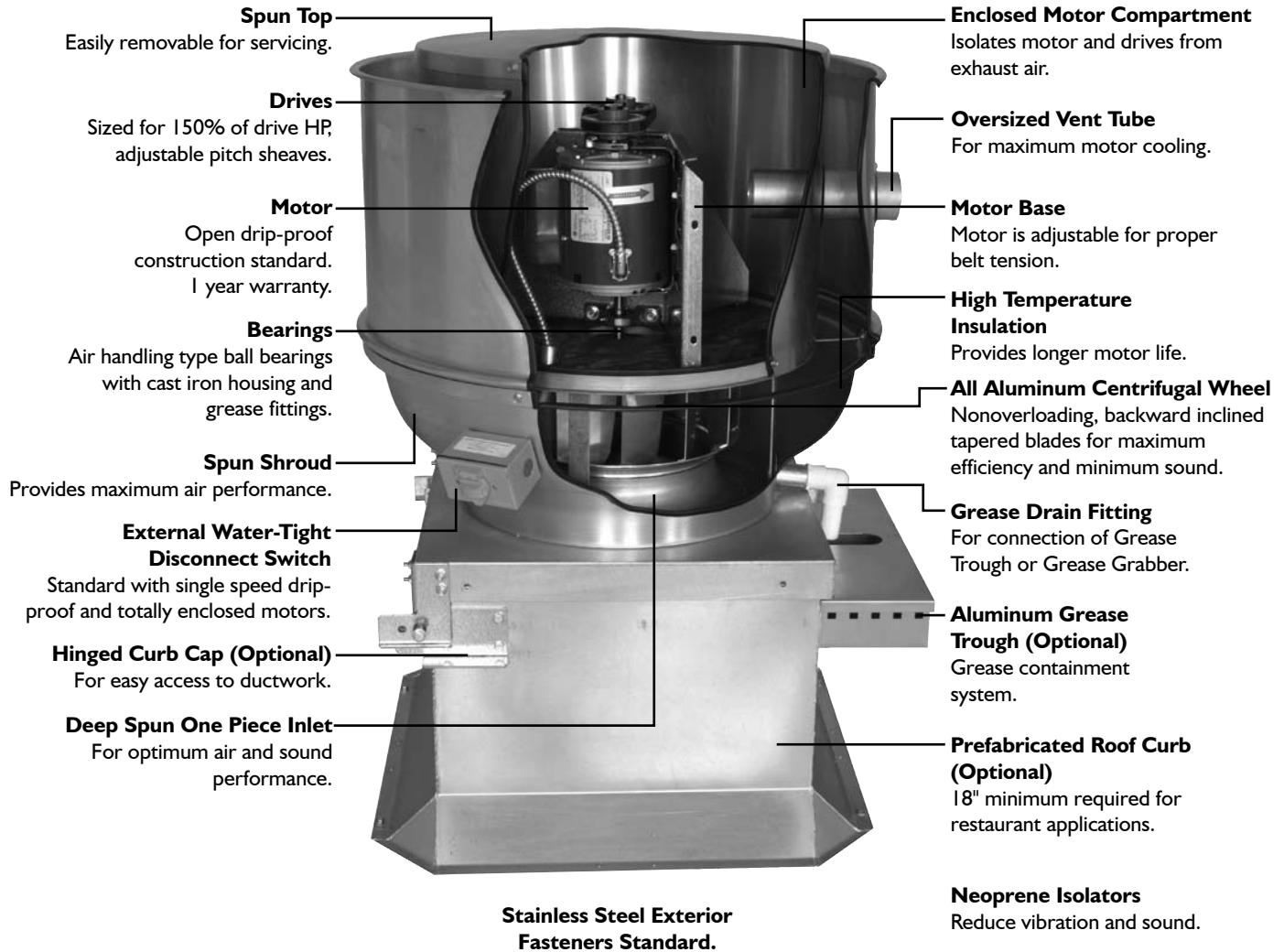

SOLER & PALAU USA LIMITED WARRANTY

Soler & Palau USA (manufacturer), 6393 Powers Avenue, Jacksonville, Florida 32217, warrants the TXB-UL762 to be free from defects in design, materials and workmanship (exclusive of abrasion, corrosion or erosion) for one (1) year from the date of shipment to the original purchaser or the date of notification of readiness to ship. Motor warranty is one (1) year. In order to claim the benefit of this warranty, buyer must notify manufacturer in writing of the claimed defect within ten (10) days after discovering it and return the equipment or parts to the factory with transportation prepaid. In the event of on-site repair, no service technician will be dispatched until manufacturer receives your written purchase order. If any of the following conditions exist, the warranty will be null and void: (1) Buyer has permitted other persons not approved or authorized by manufacturer to alter, adjust, replace or repair the equipment or any part thereof. (2) Buyer has not followed instructions or other directions given in the contract documents or our maintenance manual. (3) When breakage or other loss or damage is the result of any negligence, misuse or fault on the part of any operator or other person not under our supervision or control. (4) The defect is the result of designs or drawings made, furnished or specified by others. (5) In the case of goods not manufactured but supplied by the manufacturer as part of a contract, manufacturer shall only be liable to the same extent that our supplier is to manufacturer, not to exceed any liability manufacturer would have for warranty on our own equipment. (6) Buyer has not paid in full any invoices submitted to buyer which are due for payment. (7) Unusual wear and tear of the equipment. Statements relating to the product, its use or installation made prior to the execution of the agreement, are not warranties except to the extent that the contrary is expressly set forth herein. It is understood that such statements were not intended to, and did not, form a part of the agreement; they were merely made in the course of negotiations of the parties. **THIS WARRANTY IS IN LIEU OF ANY OTHER EXPRESS OR IMPLIED WARRANTIES, INCLUDING ANY IMPLIED WARRANTY OF MERCHANTABILITY OR FITNESS FOR ANY PARTICULAR PURPOSE. OUR SOLE AND EXCLUSIVE OBLIGATION UNDER THIS WARRANTY IS TO REPAIR OR REPLACE DEFECTIVE EQUIPMENT OR PARTS OR, AT OUR OPTION, TO PAY THE REASONABLE COST OF REPAIR OR REPLACEMENT. BUYER AGREES THAT NO OTHER REMEDY (INCLUDING, BUT NOT LIMITED TO, INCIDENTAL OR CONSEQUENTIAL DAMAGES, DAMAGES FOR LOST PROFITS OR SALES, OR DAMAGES FOR INJURIES TO PERSON OR PROPERTY) SHALL BE AVAILABLE. NOTWITHSTANDING THE ABOVE, THE TOTAL AMOUNT THAT MAY IN ANY EVENT BE PAYABLE IN SETTLEMENT OF LIABILITY, HOWEVER INCURRED, SHALL NOT EXCEED THE CONTRACT PRICE.**

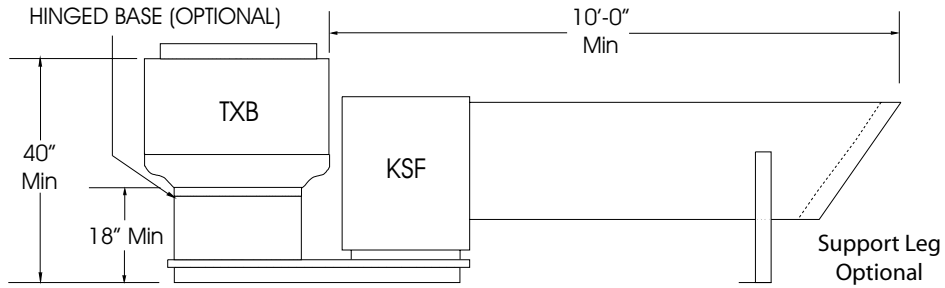

TYPICAL INSTALLATION

NFPA96 requires a 10 foot minimum distance between the exhaust fan and supply fan intake. The intake extension (optional) provides this clearance. Also required are hinged curb caps on the exhaust fan and some areas require a vented curb extension.

NFPA96 ALTERNATE INSTALLATION

Where space limitations absolutely prevent a 10 foot separation from the air intake, a vertical separation may be permitted with the exhaust outlet being a minimum of 3 feet above any air intake located within 10 feet horizontally.

IMPORTANT: Always check with the authority having jurisdiction to verify local codes and requirements.

COMMON CURB AND ADAPTOR

The common curb and adaptor allows for mounting both the exhaust fan and supply fans onto one roof opening. Follow the chart below for sizing and ordering common curbs and adaptors.

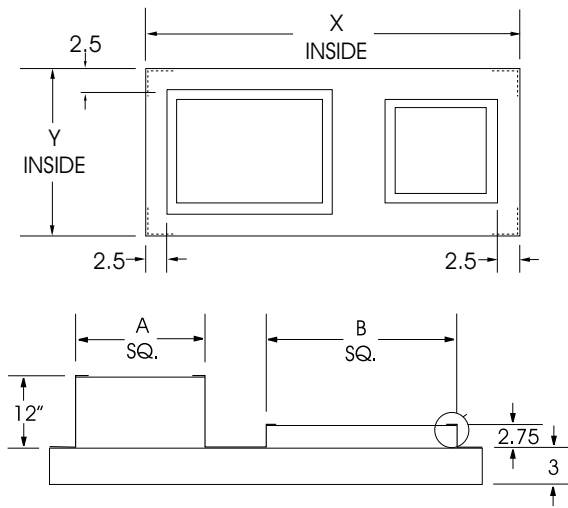

MODEL		STOCK NO. 8" HIGH COMMON CURB	COMMON CURB L x W OD	STOCK NO. CURB CAP ADAPTOR	CURB CAP ADAPTOR X x Y OD	CURB CAP OPENING	
TXB	KSF					EXHAUST FAN OUTLET A Sq.	SUPPLY FAN OUTLET B Sq.
8/10	9	2302BC10X9	55-3/4 x 27-1/2	2302BA10X9	56-3/4 x 29	16	23-3/4
12	9	2302BC12X9	59-1/4 x 27-1/2	2302BA12X9	60-3/4 x 29	23-1/2	23-3/4
15/16	10	2302BC15X10	65 x 31-1/4	2302BA15X10	66-1/2 x 32-3/4	23-1/2	27-3/4
15/16	12	2302BC15X12	69 x 35-1/4	2302BA15X12	70-1/4 x 36-3/4	23-1/2	31-3/4
15/16	15	2302BC15X15	69 x 35-1/4	2302BA15X15	70-1/4 x 36-3/4	23-1/2	31-3/4
18	12	2302BC18X12	74-1/2 x 35-1/4	2302BA18X12	76 x 36-3/4	29	31-3/4
18	15	2302BC18X15	74-1/2 x 35-1/4	2302BA18X15	76 x 36-3/4	29	31-3/4
20	12	2302BC20X12	74-1/2 x 35-1/4	2302BA20X12	76 x 36-3/4	29	31-3/4
20	15	2302BC20X15	74-1/2 x 35-1/4	2302BA20X15	76 x 36-3/4	29	31-3/4
24	15	2302BC24X15	82-1/2 x 38-1/2	2302BA24X15	84 x 40	35	31-3/4
24	18	2302BC24X18	86-1/2 x 39-1/4	2302BA24X18	88 x 40-3/4	35	35-3/4
30	18	2302BC30X18	94-1/2 x 45-3/4	2302BA30X18	96 x 47-1/4	42	35-3/4
30	20	2302BC30X20	108-1/2 x 54-1/4	2302BA30X20	110 x 55-3/4	42	50-1/4
36	20	2302BC36X20	113-1/2 x 54-1/4	2302BA36X20	115 x 55-3/4	42	50-1/4



Performance/Dimensional Data

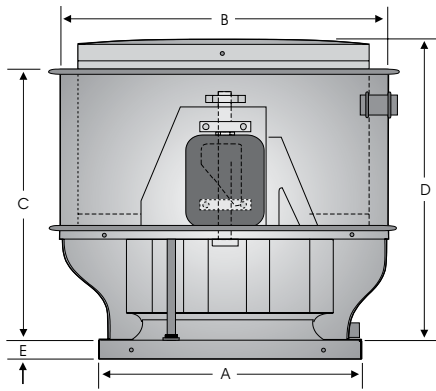

Dimensions (in.)				
A	B	C	D	E
16-1/2	24	24	27	1-3/4

Dimensional Data				Metal Thickness			Avg. Ship Wt. (lbs.)
Damper		Roof Opening	Curb OD	Curb Cap	Wind Band	Motor Cover	
ID	OD						
11	11	11-3/4	14-3/4	.063	.050	.050	68

SIZE 8

TXB 8

CFM / BHP @ Static Pressure / Sones													RPM	HP	Tip Speed
0	1/8	1/4	3/8	1/2	5/8	3/4	1	1-1/4	1-1/2	1-3/4	2	Catalog Number			
431 0.01/3.8	301 0.01/2.5	-	-	-	-	-	-	-	-	-	-	TXB-801	800	1/4	2130
485 0.02/4.6	379 0.02/3.5	-	-	-	-	-	-	-	-	-	-	TXB-802	900	1/4	2396
512 0.02/5.1	409 0.02/4.1	224 0.02/3.1	-	-	-	-	-	-	-	-	-	TXB-803	950	1/4	2629
538 0.03/5.6	439 0.03/4.7	294 0.03/3.6	-	-	-	-	-	-	-	-	-	TXB-804	1000	1/4	2662
565 0.03/6.1	468 0.03/5.3	347 0.03/4.2	-	-	-	-	-	-	-	-	-	TXB-805	1050	1/4	2796
592 0.04/6.6	496 0.03/5.8	399 0.04/4.8	-	-	-	-	-	-	-	-	-	TXB-806	1100	1/4	2929
619 0.04/7.2	525 0.04/6.4	441 0.04/5.4	249 0.04/4.5	-	-	-	-	-	-	-	-	TXB-807	1150	1/4	3062
646 0.05/7.8	554 0.05/7.0	480 0.05/6.0	329 0.04/5.1	-	-	-	-	-	-	-	-	TXB-808	1200	1/4	3195
673 0.05/8.4	583 0.05/7.6	519 0.06/6.6	389 0.05/5.7	-	-	-	-	-	-	-	-	TXB-809	1250	1/4	3328
700 0.06/9.0	612 0.06/8.2	553 0.06/7.2	439 0.06/6.3	221 0.06/5.6	-	-	-	-	-	-	-	TXB-810	1300	1/4	3461
727 0.06/9.7	641 0.06/8.8	583 0.07/7.8	492 0.07/7.0	328 0.06/6.2	-	-	-	-	-	-	-	TXB-811	1350	1/4	3594
781 0.08/10.7	698 0.08/9.9	641 0.6/9.0	571 0.09/8.1	456 0.08/7.4	236 0.08/6.7	-	-	-	-	-	-	TXB-812	1450	1/4	3861
818 0.09/11.4	738 0.09/10.6	681 0.06/9.8	628 0.10/9.0	526 0.11/8.2	384 0.09/7.5	-	-	-	-	-	-	TXB-813	1520	1/4	4047
856 0.11/12.2	777 0.11/11.3	722 0.11/10.6	676 0.11/9.8	595 0.11/9.1	476 0.10/8.4	-	-	-	-	-	-	TXB-814	1590	1/4	4233
896 0.12/13.0	820 0.12/12.2	766 0.12/11.5	721 0.13/10.7	653 0.13/10.0	553 0.13/9.3	420 0.12/8.7	-	-	-	-	-	TXB-815	1665	1/4	4433
972 0.15/14.5	899 0.16/13.9	846 0.15/13.3	802 0.16/12.6	761 0.17/11.8	687 0.17/11.1	587 0.16/10.6	-	-	-	-	-	TXB-816	1805	1/4	4806
993 0.17/15.0	921 0.17/14.4	869 0.16/13.8	825 0.17/13.1	786 0.18/12.4	717 0.18/11.6	627 0.18/11.1	334 0.17/10.0	-	-	-	-	TXB-817	1845	1/4	4912
1034 0.19/16.0	962 0.19/15.4	912 0.19/14.8	869 0.19/14.1	831 0.19/13.4	777 0.20/12.8	706 0.20/12.1	481 0.18/11.0	-	-	-	-	TXB-818	1920	1/4	5112
1074 0.21/17.1	1005 0.21/16.4	955 0.21/15.9	912 0.21/15.2	875 0.21/14.5	834 0.22/13.8	766 0.22/13.2	583 0.20/12.1	-	-	-	-	TXB-819	1995	1/4	5312
1115 0.23/18.1	1047 0.24/17.5	998 0.23/16.9	955 0.23/16.3	918 0.27/15.6	883 0.25/14.9	824 0.25/14.3	664 0.24/13.1	390 0.23/12.1	-	-	-	TXB-820	2070	1/4	5511
1141 0.25/18.8	1075 0.25/18.2	1026 0.25/17.6	984 0.25/17.1	947 0.25/16.3	913 0.26/15.6	865 0.27/15.0	713 0.27/13.8	493 0.24/12.9	-	-	-	TXB-821	2120	1/3	5644
1222 0.31/21	1159 0.31/20	1111 0.31/19.9	1070 0.31/19.3	1034 0.31/18.6	1001 0.31/18.0	969 0.33/17.3	858 0.33/16.1	697 0.30/15.0	-	-	-	TXB-822	2270	1/3	6044

Power Ratings (BHP) does not include drive losses.
 Performance certified is for installation type A - free inlet, free outlet.
 Performance ratings do not include the effects of birdscreen in the airstream.
 The sound ratings shown are loudness values in fan sones @ 5' (1.5m) in a hemispherical free field calculated per AMCA Standard 301. Values shown are for free inlet fan sone levels.



Soler & Palau USA, Div. of Soler & Palau Ventilation Group, certifies that the Models TXB shown herein are licensed to bear the AMCA Seal. The ratings shown are based on test and procedures performed in accordance with AMCA Publication 211 and AMCA Publication 311 and comply with the requirement of the AMCA Certified Ratings Program.



UL STANDARD 705 for Electrical
UL STANDARD 762 for
Grease Removal

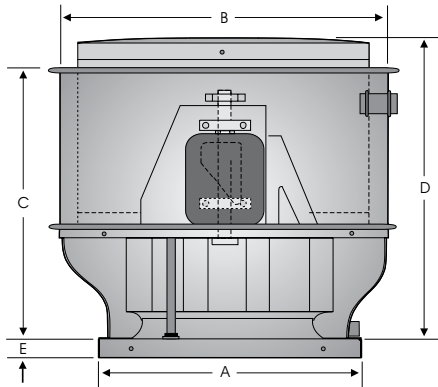

Dimensions (in.)				
A	B	C	D	E
16-1/2	27	26	29	1-3/4

Dimensional Data			Metal Thickness			Avg. Ship Wt. (lbs.)	
Damper		Roof Opening	Curb OD	Curb Cap	Wind Band		Motor Cover
ID	OD						
11	11	11-3/4	14-3/4	.063	.050	.050	70

SIZE 10

TXB 10

CFM / BHP @ Static Pressure / Sones													RPM	HP	Tip Speed
0	1/8	1/4	3/8	1/2	5/8	3/4	1	1-1/4	1-1/2	1-3/4	2	Catalog Number			
628 0.02/2.9	386 0.02/1.9	-	-	-	-	-	-	-	-	-	-	TXB-1001	640	1/4	2052
667 0.03/3.3	448 0.03/2.3	-	-	-	-	-	-	-	-	-	-	TXB-1002	680	1/4	2181
706 0.03/3.7	506 0.03/2.8	-	-	-	-	-	-	-	-	-	-	TXB-1003	720	1/4	2309
746 0.04/4.2	560 0.04/3.3	-	-	-	-	-	-	-	-	-	-	TXB-1004	760	1/4	2437
785 0.05/4.8	612 0.05/3.8	349 0.04/3.5	-	-	-	-	-	-	-	-	-	TXB-1005	800	1/4	2566
863 0.06/5.8	711 0.06/4.9	504 0.06/4.4	-	-	-	-	-	-	-	-	-	TXB-1006	880	1/4	2822
903 0.07/6.3	758 0.07/5.5	570 0.07/4.9	-	-	-	-	-	-	-	-	-	TXB-1007	920	1/4	2950
981 0.09/7.5	851 0.09/6.6	689 0.09/6.0	471 0.09/5.8	-	-	-	-	-	-	-	-	TXB-1008	1000	1/4	3207
1020 0.10/8.0	896 0.11/7.2	745 0.11/6.6	550 0.10/6.3	242 0.08/6.3	-	-	-	-	-	-	-	TXB-1009	1040	1/4	3335
1099 0.13/9.3	985 0.13/8.4	851 0.13/7.8	687 0.13/7.3	468 0.12/7.3	-	-	-	-	-	-	-	TXB-1010	1120	1/4	3592
1128 0.14/9.7	1017 0.14/8.8	889 0.14/8.2	734 0.14/7.7	534 0.13/7.6	-	-	-	-	-	-	-	TXB-1011	1150	1/4	3688
1236 0.18/11.1	1136 0.19/10.3	1023 0.19/9.6	894 0.19/9.1	739 0.18/8.8	542 0.17/8.8	-	-	-	-	-	-	TXB-1012	1260	1/4	4041
1290 0.21/12	1195 0.21/11.1	1088 0.21/10.4	968 0.21/9.9	828 0.21/9.5	657 0.20/9.4	429 0.18/9.4	-	-	-	-	-	TXB-1013	1315	1/4	4217
1339 0.23/12.7	1248 0.24/11.9	1146 0.24/11.2	1033 0.24/10.6	903 0.24/10.2	750 0.23/10.1	558 0.22/10.1	-	-	-	-	-	TXB-1014	1365	1/4	4378
1393 0.26/13.5	1306 0.26/12.8	1209 0.27/12.1	1103 0.27/11.5	983 0.27/11.1	845 0.26/10.7	678 0.25/10.7	-	-	-	-	-	TXB-1015	1420	1/4	4554
1452 0.29/14.5	1368 0.30/13.8	1277 0.30/13.2	1177 0.30/12.5	1066 0.30/12.1	940 0.30/11.6	794 0.29/11.6	-	-	-	-	-	TXB-1016	1480	1/3	4746
1501 0.32/15.5	1421 0.33/14.6	1334 0.34/13.9	1238 0.34/13.3	1133 0.34/12.9	1015 0.33/12.5	881 0.33/12.3	530 0.29/12.3	-	-	-	-	TXB-1017	1530	1/3	4907
1540 0.35/16.2	1462 0.36/15.5	1377 0.36/14.8	1285 0.36/14.1	1185 0.36/13.6	1074 0.36/13.2	949 0.36/12.9	630 0.33/12.9	-	-	-	-	TXB-1018	1570	1/2	5033
1570 0.37/16.8	1493 0.38/16.1	1410 0.38/15.4	1321 0.38/14.7	1223 0.38/14.1	1116 0.38/13.7	997 0.38/13.4	699 0.35/13.4	-	-	-	-	TXB-1019	1600	1/2	5131
1599 0.39/17.4	1524 0.40/16.7	1443 0.40/16.0	1356 0.41/15.3	1261 0.41/14.7	1158 0.41/14.3	1044 0.40/13.9	763 0.38/13.8	-	-	-	-	TXB-1020	1630	1/2	5227
1638 0.42/18.1	1565 0.43/17.4	1486 0.43/16.8	1402 0.44/16.1	1311 0.44/15.5	1213 0.44/15.1	1104 0.43/14.7	844 0.42/14.5	471 0.36/14.5	-	-	-	TXB-1021	1670	1/2	5356
1731 0.50/20	1663 0.51/19.2	1589 0.51/18.4	1511 0.52/17.8	1428 0.52/17.4	1338 0.52/16.9	1240 0.51/16.6	1015 0.50/16.1	727 0.47/16.1	-	-	-	TXB-1022	1765	1/2	5660

Power Ratings (BHP) does not include drive losses.
 Performance certified is for installation type A - free inlet, free outlet.
 Performance ratings do not include the effects of birdscreen in the airstream.
 The sound ratings shown are loudness values in fan sones @ 5' (1.5m) in a hemispherical free field calculated per AMCA Standard 301. Values shown are for free inlet fan sone levels.



Soler & Palau USA, Div. of Soler & Palau Ventilation Group, certifies that the Models TXB shown herein are licensed to bear the AMCA Seal. The ratings shown are based on test and procedures performed in accordance with AMCA Publication 211 and AMCA Publication 311 and comply with the requirement of the AMCA Certified Ratings Program.



UL STANDARD 705 for Electrical
 UL STANDARD 762 for Grease Removal

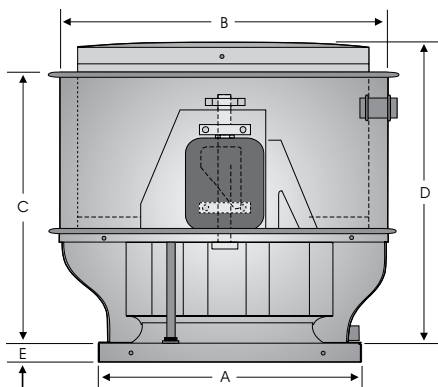

Dimensions (in.)				
A	B	C	D	E
24	31-1/2	26	29	2-1/2

Dimensional Data		Metal Thickness				Avg. Ship Wt. (lbs.)	
Damper ID	Roof OD	Curb OD	Curb Cap	Wind Band	Motor Cover		
18	18	19-1/4	22-1/4	.063	.050	.050	90

SIZE 12

CFM / BHP @ Static Pressure / Sones													RPM	HP	Tip Speed
0	1/8	1/4	3/8	1/2	5/8	3/4	1	1-1/4	1-1/2	1-3/4	2	Catalog Number			
1055 0.09/7.7	945 0.09/7.2	836 0.09/6.8	687 0.09/6.4	466 0.11/6.9	-	-	-	-	-	-	-	TXB-12161	1050	1/4	3367
1120 0.10/8.7	1016 0.11/8.2	916 0.11/7.8	789 0.11/7.3	623 0.11/6.9	-	-	-	-	-	-	-	TXB-12162	1115	1/4	3576
1185 0.12/9.8	1085 0.13/9.3	994 0.13/8.8	883 0.13/8.3	740 0.13/7.9	539 0.13/7.6	-	-	-	-	-	-	TXB-12163	1180	1/4	3784
1251 0.14/10.6	1154 0.15/10.1	1070 0.15/9.6	970 0.15/9.1	845 0.15/8.7	693 0.15/8.4	383 0.13/8.1	-	-	-	-	-	TXB-12164	1245	1/4	3993
1316 0.17/11.5	1223 0.17/11.0	1144 0.18/10.6	1054 0.18/10.2	945 0.18/9.8	812 0.18/9.4	638 0.17/9.0	-	-	-	-	-	TXB-12165	1310	1/4	4201
1346 0.18/12.0	1255 0.18/11.5	1177 0.19/11.1	1091 0.19/10.6	988 0.19/10.2	862 0.19/9.9	709 0.19/9.5	-	-	-	-	-	TXB-12251	1340	1/4	4297
1381 0.19/12.5	1292 0.20/12.1	1217 0.21/11.7	1134 0.21/11.2	1037 0.21/10.8	918 0.21/10.4	782 0.21/10.1	-	-	-	-	-	TXB-12252	1375	1/4	4410
1411 0.21/13.0	1323 0.21/12.6	1250 0.22/12.1	1170 0.22/11.7	1077 0.22/11.3	966 0.22/11.0	837 0.22/10.6	-	-	-	-	-	TXB-12253	1405	1/4	4506
1446 0.22/13.6	1360 0.23/13.6	1288 0.24/12.7	1211 0.24/12.3	1124 0.24/11.9	1019 0.24/11.6	898 0.24/11.2	461 0.20/10.7	-	-	-	-	TXB-12254	1440	1/4	4618
1477 0.24/14.1	1391 0.24/13.6	1321 0.25/13.2	1246 0.25/12.9	1163 0.25/12.5	1064 0.25/12.1	948 0.25/11.7	610 0.23/11.1	-	-	-	-	TXB-12255	1470	1/4	4714
1507 0.25/14.6	1423 0.26/14.2	1353 0.27/13.7	1281 0.27/13.3	1201 0.27/13.0	1107 0.27/12.6	996 0.27/12.3	703 0.26/11.6	-	-	-	-	TXB-12256	1500	1/4	4810
1542 0.27/15.2	1459 0.27/14.8	1391 0.28/14.4	1322 0.29/14.0	1245 0.29/13.6	1156 0.29/13.2	1051 0.29/12.9	791 0.28/12.2	-	-	-	-	TXB-12331	1535	1/3	4923
1577 0.29/15.9	1496 0.29/15.4	1429 0.30/15.0	1362 0.31/14.6	1288 0.31/14.3	1204 0.31/13.9	1105 0.31/13.5	867 0.31/12.9	-	-	-	-	TXB-12332	1570	1/3	5035
1617 0.31/16.6	1538 0.32/16.2	1472 0.33/15.8	1407 0.33/15.4	1336 0.33/15.0	1256 0.33/14.7	1165 0.33/14.3	944 0.33/13.6	515 0.28/13.1	-	-	-	TXB-12333	1610	1/3	5163
1652 0.33/17.2	1574 0.34/16.8	1509 0.35/17.0	1446 0.35/17.0	1378 0.35/16.0	1302 0.35/16.0	1215 0.35/16.0	1006 0.35/15.0	687 0.33/14.0	-	-	-	TXB-12334	1645	1/3	5275
1713 0.37/19.0	1636 0.37/19.0	1573 0.38/18.0	1513 0.39/18.0	1448 0.39/17.0	1378 0.39/17.0	1298 0.39/17.0	1106 0.39/16.0	858 0.39/16.0	-	-	-	TXB-12501	1705	1/2	5468
1773 0.41/20	1699 0.41/20	1637 0.42/20	1579 0.44/19.0	1517 0.44/19.0	1451 0.44/18.0	1378 0.44/18.0	1202 0.44/17.0	898 0.44/17.0	573 0.37/16.0	-	-	TXB-12502	1765	1/2	5660
1838 0.45/22	1766 0.46/22	1706 0.47/21	1650 0.48/21	1592 0.49/20	1529 0.49/20	1462 0.49/20	1302 0.49/19.0	1109 0.49/18.0	841 0.47/18.0	-	-	TXB-12503	1830	1/2	5869
1898 0.50/24	1828 0.51/23	1769 0.52/23	1715 0.53/22	1659 0.54/22	1600 0.54/21	1537 0.54/21	1390 0.54/20	1211 0.54/20	992 0.53/19.0	-	-	TXB-12504	1890	1/2	6061
1969 0.56/25	1900 0.56/25	1843 0.58/25	1790 0.59/24	1738 0.60/24	1681 0.60/23	1622 0.60/23	1487 0.60/22	1323 0.60/22	1134 0.60/21	858 0.57/21	-	TXB-12751	1960	3/4	6286
2039 0.62/27	1972 0.63/27	1917 0.64/26	1865 0.65/26	1815 0.66/26	1761 0.67/25	1705 0.67/25	1581 0.66/24	1432 0.66/24	1258 0.67/23	1045 0.65/22	601 0.54/22	TXB-12752	2030	3/4	6510
2104 0.68/29	2039 0.69/29	1985 0.70/28	1934 0.71/28	1886 0.73/28	1835 0.73/27	1781 0.73/27	1665 0.73/26	1528 0.73/25	1366 0.73/25	1184 0.73/24	917 0.69/24	TXB-12753	2095	3/4	6719
2175 0.75/32	2111 0.76/31	2058 0.77/31	2009 0.78/30	1961 0.80/30	1913 0.81/29	1862 0.81/29	1753 0.81/28	1627 0.81/27	1478 0.81/27	1312 0.81/26	1105 0.79/26	TXB-12754	2165	3/4	6943

Power Ratings (BHP) does not include drive losses.
 Performance certified is for installation type A - free inlet, free outlet.
 Performance ratings do not include the effects of birdscreen in the airstream.
 The sound ratings shown are loudness values in fan sones @ 5' (1.5m) in a hemispherical free field calculated per AMCA Standard 301. Values shown are for free inlet fan sone levels.



Soler & Palau USA, Div. of Soler & Palau Ventilation Group, certifies that the Models TXB shown herein are licensed to bear the AMCA Seal. The ratings shown are based on test and procedures performed in accordance with AMCA Publication 211 and AMCA Publication 311 and comply with the requirement of the AMCA Certified Ratings Program.



UL STANDARD 705 for Electrical
 UL STANDARD 762 for
 Grease Removal

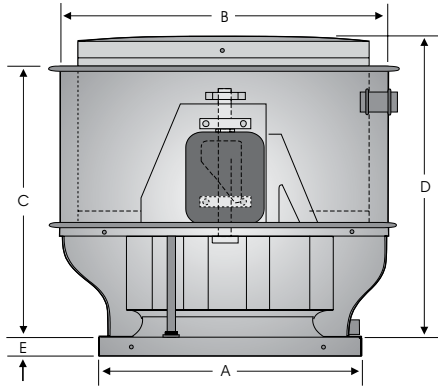

Dimensions (in.)				
A	B	C	D	E
24	31-1/2	26	29	2-1/2

Dimensional Data				Metal Thickness			Avg. Ship Wt. (lbs.)
Damper		Roof Opening	Curb OD	Curb Cap	Wind Band	Motor Cover	
ID	OD						
18	18	19-1/4	22-1/4	.063	.050	.050	95

SIZE 15

TXB 15

CFM / BHP @ Static Pressure / Sones													RPM	HP	Tip Speed
0	1/8	1/4	3/8	1/2	5/8	3/4	1	1-1/4	1-1/2	1-3/4	2	Catalog Number			
1525 0.09/6.8	1301 0.09/6.0	1019 0.09/5.2	-	-	-	-	-	-	-	-	-	TXB-15161	700	1/4	2792
1710 0.12/8.3	1513 0.13/7.4	1286 0.13/6.9	972 0.12/5.9	-	-	-	-	-	-	-	-	TXB-15162	785	1/4	3134
1895 0.17/9.9	1719 0.17/9.0	1525 0.18/8.4	1291 0.17/7.7	944 0.16/6.9	-	-	-	-	-	-	-	TXB-15163	870	1/4	3473
1938 0.18/10.3	1767 0.19/9.4	1579 0.19/8.8	1356 0.18/7.3	1047 0.18/7.3	-	-	-	-	-	-	-	TXB-15251	890	1/4	3553
1982 0.19/10.7	1814 0.20/9.8	1632 0.20/9.2	1420 0.20/8.7	1137 0.19/7.7	544 0.15/7.4	-	-	-	-	-	-	TXB-15252	910	1/4	3633
2026 0.21/11.1	1862 0.21/10.2	1685 0.21/9.6	1481 0.21/9.2	1220 0.21/8.2	763 0.18/7.7	-	-	-	-	-	-	TXB-15253	930	1/4	3713
2080 0.22/11.6	1921 0.23/10.8	1750 0.23/10.1	1556 0.23/9.7	1317 0.23/8.8	951 0.21/8.1	-	-	-	-	-	-	TXB-15254	955	1/4	3813
2124 0.24/12.1	1968 0.24/11.2	1801 0.25/10.6	1615 0.25/10.1	1389 0.24/9.3	1068 0.23/8.4	-	-	-	-	-	-	TXB-15255	975	1/4	3893
2167 0.25/12.5	2015 0.26/11.6	1852 0.26/11.1	1672 0.26/10.6	1458 0.26/9.8	1170 0.25/8.9	572 0.19/8.8	-	-	-	-	-	TXB-15256	995	1/4	3972
2243 0.28/13.3	2096 0.29/12.4	1941 0.29/11.9	1770 0.29/11.4	1574 0.29/10.8	1325 0.28/9.9	929 0.25/9.4	-	-	-	-	-	TXB-15331	1030	1/3	4112
2309 0.31/13.9	2166 0.31/13.1	2016 0.32/12.7	1853 .32/12.2	1668 0.32/11.6	1443 0.31/10.7	1125 0.29/9.9	-	-	-	-	-	TXB-15332	1060	1/3	4232
2385 0.34/14.7	2247 0.34/13.9	2103 0.35/13.5	1947 0.35/13.1	1774 0.35/12.6	1570 0.34/11.7	1305 0.33/10.8	-	-	-	-	-	TXB-15333	1095	1/3	4372
2472 0.38/15.7	2339 0.38/14.9	2201 0.39/14.5	2053 0.39/14.0	1891 0.39/13.6	1706 0.39/12.9	1479 0.38/12.0	-	-	-	-	-	TXB-15501	1135	1/2	4531
2559 0.42/16.7	2431 0.42/16.0	2298 0.43/15.6	2157 0.43/15.1	2004 0.43/14.6	1833 0.43/14.1	1632 0.42/13.2	953 0.35/12.1	-	-	-	-	TXB-15502	1175	1/2	4691
2646 0.46/17.7	2522 0.47/17.1	2394 0.47/16.7	2260 0.48/16.3	2115 0.48/15.8	1956 0.48/15.3	1774 0.47/14.4	1247 0.43/13.0	-	-	-	-	TXB-15503	1215	1/2	4851
2733 0.51/18.7	2613 0.52/18.2	2490 0.52/17.8	2361 0.52/17.4	2223 0.53/16.9	2074 0.53/16.4	1906 0.52/15.7	1462 0.49/14.0	-	-	-	-	TXB-15504	1255	1/2	5011
2831 0.57/19.8	2715 0.57/19.2	2597 0.58/18.8	2473 0.58/18.4	2343 0.58/17.9	2203 0.58/17.4	2048 0.58/17.0	1664 0.56/15.2	928 0.46/14.5	-	-	-	TXB-15751	1300	3/4	5190
2929 0.63/21	2817 0.63/20	2703 0.64/19.8	2585 0.64/19.4	2460 0.65/19.0	2328 0.65/18.5	2184 0.65/18.0	1841 0.63/16.5	1308 0.57/15.2	-	-	-	TXB-15752	1345	3/4	5370
3027 0.69/22	2919 0.70/21	2809 0.70/21	2695 0.71/20	2576 0.71/20	2450 0.71/19.6	2316 0.71/19.1	2003 0.70/17.7	1569 0.66/16.1	-	-	-	TXB-15753	1390	3/4	5549
3125 0.76/23	3020 0.77/22	2914 0.77/22	2804 0.78/21	2690 0.78/21	2571 0.79/21	2444 0.79/20	2155 0.78/19.0	1782 0.75/17.4	1129 0.64/16.7	-	-	TXB-15754	1435	3/4	5729
3213 0.83/24	3110 0.83/24	3007 0.84/23	2901 0.85/22	2791 0.85/22	2676 0.85/22	2555 0.85/21	2284 0.85/20	1948 0.83/18.5	1444 0.75/17.4	-	-	TXB-15101	1475	1	5889
3330 0.90/25	3200 0.90/25	3100 0.91/24	2997 0.92/23	2891 0.92/23	2780 0.92/23	2664 0.93/22	2408 0.92/21	2100 0.91/19.7	1679 0.85/18.2	805 0.64/18.1	-	TXB-15102	1515	1	6049
3376 0.96/26	3279 0.97/25	3181 0.97/25	3080 0.98/24	2977 0.98/24	2870 0.99/24	2758 0.99/23	2513 0.99/22	2226 0.98/21	1853 0.93/19.3	1220 0.80/18.8	-	TXB-15103	1550	1	6188
3463 1.04/27	3368 1.04/27	3273 1.05/26	3175 1.06/25	3075 1.06/25	2972 1.07/25	2864 1.07/24	2631 1.07/23	2362 1.06/22	2029 1.03/21	1538 0.94/19.6	-	TXB-15104	1590	1	6348
3692 1.26/30	3603 1.26/30	3514 1.27/29	3423 1.28/28	3330 1.28/28	3235 1.29/27	3136 1.29/27	2927 1.30/26	2696 1.29/26	2428 1.28/24	2095 1.23/23	1612 1.13/22	TXB-15151	1695	1-1/2	6767
3931 1.52/34	3848 1.53/33	3764 1.53/32	3679 1.54/32	3593 1.55/31	3505 1.55/31	3414 1.56/30	3225 1.56/30	3020 1.57/29	2792 1.56/28	2530 1.53/26	2209 1.49/25	TXB-15152	1805	1-1/2	7206

Power Ratings (BHP) does not include drive losses.
 Performance certified is for installation type A - free inlet, free outlet.
 Performance ratings do not include the effects of birdscreen in the airstream.
 The sound ratings shown are loudness values in fan sones @ 5' (1.5m) in a hemispherical free field calculated per AMCA Standard 301. Values shown are for free inlet fan sone levels.



Soler & Palau USA, Div. of Soler & Palau Ventilation Group, certifies that the Models TXB shown herein are licensed to bear the AMCA Seal. The ratings shown are based on test and procedures performed in accordance with AMCA Publication 211 and AMCA Publication 311 and comply with the requirement of the AMCA Certified Ratings Program.



UL STANDARD 705 for Electrical
UL STANDARD 762 for
Grease Removal

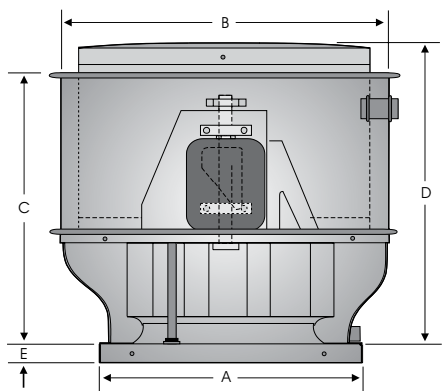

Dimensions (in.)				
A	B	C	D	E
24	31-1/2	26	29	2-1/2

Dimensional Data		Metal Thickness				Avg. Ship Wt. (lbs.)	
Damper ID	Roof OD	Curb OD	Curb Cap	Wind Band	Motor Cover		
18	18	19-1/4	22-1/4	.063	.050	.050	95

SIZE 15 - HIGH PRESSURE

Performance/Dimensional Data

TXBHP 15

CFM / BHP @ Static Pressure / Sones													Catalog Number	RPM	HP	Tip Speed
1/4	3/8	1/2	5/8	3/4	1	1-1/4	1-1/2	1-3/4	2	2-1/4	2-1/2					
1033 0.09/5.4	573 0.07/4.8	-	-	-	-	-	-	-	-	-	-	-	TXBHP-15161	740	1/4	2954
1266 0.13/7.5	1003 0.12/6.1	-	-	-	-	-	-	-	-	-	-	-	TXBHP-15162	825	1/4	3294
1479 0.17/9.7	1276 0.17/8.2	989 0.16/7.4	-	-	-	-	-	-	-	-	-	-	TXBHP-15163	910	1/4	3633
1539 0.18/10.4	1348 0.18/8.9	1092 0.18/7.8	-	-	-	-	-	-	-	-	-	-	TXBHP-15251	935	1/4	3733
1586 0.19/11.0	1403 0.19/9.5	1166 0.19/8.2	737 0.16/8.2	-	-	-	-	-	-	-	-	-	TXBHP-15252	955	1/4	3813
1645 0.21/11.7	1471 0.21/10.3	1253 0.21/8.9	916 0.19/8.7	-	-	-	-	-	-	-	-	-	TXBHP-15253	980	1/4	3913
1692 0.22/12.3	1524 0.22/10.9	1319 0.22/9.4	1024 0.21/9.0	-	-	-	-	-	-	-	-	-	TXBHP-15254	1000	1/4	3992
1749 0.24/13.1	1589 0.24/11.7	1397 0.24/10.2	1138 0.23/9.5	-	-	-	-	-	-	-	-	-	TXBHP-15255	1025	1/4	4092
1795 0.25/13.8	1640 0.26/12.4	1456 0.25/10.8	1219 0.24/9.9	796 0.21/9.9	-	-	-	-	-	-	-	-	TXBHP-15256	1045	1/4	4172
1874 0.28/14.9	1727 0.28/13.6	1557 0.28/11.8	1348 0.27/10.6	1041 0.25/10.6	-	-	-	-	-	-	-	-	TXBHP-15331	1080	1/3	4312
1941 0.30/15.4	1800 0.31/14.3	1640 0.31/12.7	1448 0.30/11.4	1190 0.29/11.0	-	-	-	-	-	-	-	-	TXBHP-15332	1110	1/3	4432
2019 0.33/16.2	1885 0.33/15.1	1734 0.34/13.7	1558 .33/12.2	1337 0.32/11.5	-	-	-	-	-	-	-	-	TXBHP-15333	1145	1/3	4571
2118 0.37/17.1	1991 0.37/16.3	1851 0.38/14.9	1691 .38/13.4	1500 0.37/12.2	-	-	-	-	-	-	-	-	TXBHP-15501	1190	1/2	4751
2205 0.41/17.9	2084 0.41/17.3	1952 0.42/16.1	1804 .42/14.6	1632 0.41/13.3	1100 0.36/12.7	-	-	-	-	-	-	-	TXBHP-15502	1230	1/2	4911
2292 0.45/18.7	2176 0.45/18.4	2050 .46/17.2	1912 .46/15.8	1755 0.46/14.5	1320 0.42/13.4	-	-	-	-	-	-	-	TXBHP-15503	1270	1/2	5070
2378 0.49/19.5	2267 0.50/19.4	2147 0.50/18.3	2017 .50/16.9	1871 0.50/15.7	1495 0.48/14.1	-	-	-	-	-	-	-	TXBHP-15504	1310	1/2	5230
2485 0.55/20	2379 0.55/20	2266 0.56/19.6	2144 .56/18.5	2010 0.56/17.1	1683 0.55/15.1	1121 0.47/15.0	-	-	-	-	-	-	TXBHP-15751	1360	3/4	5430
2580 0.60/21	2479 0.61/21	2371 0.62/21	2256 0.62/19.8	2131 0.62/18.6	1835 0.61/16.4	1402 0.56/15.9	-	-	-	-	-	-	TXBHP-15752	1405	3/4	5609
2686 0.67/23	2589 0.68/23	2486 0.68/22	2377 0.69/21	2261 0.69/20	1992 0.68/17.9	1632 0.65/16.9	824 0.48/16.9	-	-	-	-	-	TXBHP-15753	1455	3/4	5809
2781 0.73/23	2687 0.74/23	2589 0.75/23	2485 0.75/22	2374 0.75/21	2124 0.75/19.3	1808 0.73/17.7	1303 0.65/17.7	-	-	-	-	-	TXBHP-15754	1500	3/4	5989
2875 0.80/24	2784 0.81/24	2690 0.81/24	2591 0.82/24	2486 0.82/23	2252 0.82/21	1966 0.81/18.9	1566 0.75/18.7	-	-	-	-	-	TXBHP-15101	1545	1	6168
2969 0.87/26	2881 0.88/26	2790 0.89/26	2695 0.89/25	2595 0.90/24	2374 0.90/22	2113 0.89/20	1772 0.85/19.6	1154 0.71/19.6	-	-	-	-	TXBHP-15102	1590	1	6348
3062 0.95/27	2978 0.95/27	2890 0.96/27	2799 0.97/27	2703 0.97/26	2494 0.98/24	2251 0.97/22	1950 0.94/21	1504 0.86/21	-	-	-	-	TXBHP-15103	1635	1	6527
3156 1.03/29	3074 1.03/29	2989 1.04/29	2901 1.05/29	2809 1.05/28	2610 1.06/26	2384 1.06/24	2111 1.04/22	1746 0.98/21	950 0.74/21	-	-	-	TXBHP-15104	1680	1	6707
3372 1.23/33	3296 1.24/33	3217 1.25/33	3136 1.25/33	3052 1.26/32	2873 1.27/30	2674 1.27/28	2448 1.26/26	2176 1.23/24	1813 1.16/24	1067 0.91/24	-	-	TXBHP-15151	1785	1-1/2	7127
3598 1.47/37	3527 1.48/37	3454 1.49/37	3378 1.49/37	3301 1.50/37	3137 1.51/35	2961 1.52/33	2765 1.52/30	2543 1.51/28	2278 1.47/27	1931 1.40/27	1318 1.18/27	-	TXBHP-15152	1895	1-1/2	7568

Power Ratings (BHP) does not include drive losses.
 Performance certified is for installation type A - free inlet, free outlet.
 Performance ratings do not include the effects of birdscreen in the airstream.
 The sound ratings shown are loudness values in fan sones @ 5' (1.5m) in a hemispherical free field calculated per AMCA Standard 301. Values shown are for free inlet fan sone levels.



Soler & Palau USA, Div. of Soler & Palau Ventilation Group, certifies that the Models TXB shown herein are licensed to bear the AMCA Seal. The ratings shown are based on test and procedures performed in accordance with AMCA Publication 211 and AMCA Publication 311 and comply with the requirement of the AMCA Certified Ratings Program.



UL STANDARD 705 for Electrical
 UL STANDARD 762 for Grease Removal

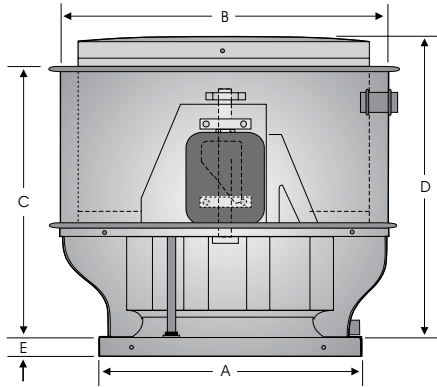

Dimensions (in.)				
A	B	C	D	E
24	31-1/2	26	29	2-1/2

Dimensional Data				Metal Thickness			Avg. Ship Wt. (lbs.)
Damper		Roof Opening	Curb OD	Curb Cap	Wind Band	Motor Cover	
ID	OD						
18	18	19-1/4	22-1/4	.063	.050	.050	100

SIZE 16

TXB 16

CFM / BHP @ Static Pressure / Sones													RPM	HP	Tip Speed
0	1/8	1/4	3/8	1/2	5/8	3/4	7/8	1	1-1/4	1-1/2	1-3/4	Catalog Number			
2223 0.15/7.9	2016 0.16/7.5	1746 0.16/6.7	1375 0.15/5.2	-	-	-	-	-	-	-	-	TXB-1601	680	1/4	3202
2289 0.16/8.4	2086 0.17/7.9	1829 0.18/7.2	1490 0.17/5.7	-	-	-	-	-	-	-	-	TXB-1602	700	1/4	3297
2354 0.18/8.8	2156 0.19/8.3	1911 0.19/7.7	1594 0.19/6.3	1007 0.16/5.1	-	-	-	-	-	-	-	TXB-1603	720	1/4	3391
2485 0.21/9.8	2295 0.22/9.2	2071 0.23/8.8	1796 0.22/7.4	1410 0.21/6.2	-	-	-	-	-	-	-	TXB-1604	760	1/4	3580
2550 0.23/10.2	2364 0.24/9.8	2152 0.24/9.3	1897 0.24/8.1	1554 0.23/6.8	-	-	-	-	-	-	-	TXB-1605	780	1/4	3674
2616 0.24/10.7	2432 0.26/10.2	2235 0.26/9.8	1993 0.27/8.7	1676 0.25/7.3	1052 0.21/6.2	-	-	-	-	-	-	TXB-1606	800	1/4	3768
2681 0.26/11.2	2501 0.28/10.8	2317 0.28/10.3	2084 0.29/9.3	1782 0.28/8.0	1307 0.25/6.8	-	-	-	-	-	-	TXB-1607	820	1/3	3862
2747 0.28/11.7	2569 0.30/11.3	2397 0.30/10.9	2169 0.31/9.9	1884 0.30/8.6	1495 0.28/7.4	-	-	-	-	-	-	TXB-1608	840	1/3	3956
2877 0.32/12.8	2705 0.35/12.3	2553 0.35/11.9	2333 0.35/11.4	2087 0.35/9.9	1789 0.34/8.6	1208 0.28/7.5	-	-	-	-	-	TXB-1609	880	1/3	4145
2943 0.35/13.3	2773 0.37/12.9	2629 0.37/12.5	2413 0.38/12.1	2187 0.38/10.6	1904 0.36/9.3	1450 0.33/8.2	-	-	-	-	-	TXB-1610	900	1/2	4239
3057 0.39/14.3	2892 0.41/13.9	2757 0.41/13.9	2553 0.42/13.1	2353 0.42/11.9	2086 0.41/10.5	1759 0.39/9.3	1025 0.30/8.3	-	-	-	-	TXB-1611	935	1/2	4404
3172 0.43/15.3	3010 0.46/14.9	2881 0.47/14.6	2697 0.47/14.2	2505 0.48/13.1	2262 0.46/11.8	1997 0.45/10.5	1545 0.41/9.5	-	-	-	-	TXB-1612	970	1/2	4569
3270 0.48/16.2	3111 0.50/15.8	2986 0.51/15.5	2820 0.51/15.1	2628 0.52/14.4	2414 0.51/12.9	2161 0.50/11.7	1821 0.47/10.5	1105 0.37/9.5	-	-	-	TXB-1613	1000	1/2	4710
3335 0.51/16.8	3179 0.50/16.4	3056 0.54/16.1	2901 0.54/15.7	2709 0.55/15.2	2512 0.55/13.7	2264 0.53/12.4	1975 0.51/11.2	1448 0.45/10.1	-	-	-	TXB-1614	1020	1/2	4804
3433 0.55/17.7	3280 0.58/17.3	3160 0.59/17.0	3020 0.59/16.7	2830 0.60/16.3	2652 0.60/14.9	2413 0.59/13.5	2170 0.57/12.3	1780 0.53/11.2	-	-	-	TXB-1615	1050	3/4	4946
3531 0.60/18.6	3381 0.63/18.3	3263 0.64/18.0	3136 0.64/17.6	2949 0.65/17.3	2781 0.66/16.2	2567 0.64/14.8	2333 0.63/13.5	2034 0.60/12.4	-	-	-	TXB-1616	1080	3/4	5087
3629 0.65/19.6	3481 0.69/19.3	3367 0.70/19.0	3249 0.70/18.7	3073 0.70/18.4	2906 0.71/17.4	2716 0.71/16	2487 0.69/14.8	2243 0.67/13.5	-	-	-	TXB-1617	1110	3/4	5181
3728 0.71/21	3582 0.74/20	3469 0.75/19.9	3358 0.76/19.7	3197 0.76/19.4	3028 0.77/18.8	2858 0.77/17.3	2636 0.75/16.0	2417 0.74/14.8	1613 0.63/12.6	-	-	TXB-1618	1140	3/4	5369
3826 0.76/22	3682 0.80/21	3572 0.81/21	3465 0.82/21	3319 0.82/20	3148 0.83/20	2992 0.83/18.7	2790 0.82/17.3	2574 0.80/16.0	1953 0.73/13.8	-	-	TXB-1619	1170	1	5511
3907 0.81/22	3766 0.85/22	3657 0.87/22	3553 0.87/22	3419 0.87/21	3248 0.88/21	3097 0.89/19.9	2914 0.88/18.5	2700 0.86/17.1	2175 0.81/14.9	-	-	TXB-1620	1195	1	5628
4038 0.90/24	3900 0.94/24	3794 0.96/23	3693 0.96/23	3574 0.96/23	3410 0.97/23	3261 0.98/22	3104 0.98/20	2902 0.96/19.0	2469 0.92/16.5	1556 0.75/14.5	-	TXB-1621	1235	1	5817
4169 0.99/25	4034 1.03/25	3929 1.05/25	3832 1.06/24	3727 1.06/24	3576 1.07/24	3422 1.07/24	3279 1.08/22	3103 1.07/21	2704 1.03/18.2	2073 1.03/16	-	TXB-1622	1275	1	6005
4218 1.02/26	4084 1.07/25	3980 1.09/25	3884 1.09/25	3783 1.09/24	3637 1.10/24	3482 1.11/24	3342 1.12/23	3176 1.11/21	2784 1.07/18.8	2218 1.07/16.5	-	TXB-1623	1290	1	6076

Power Ratings (BHP) does not include drive losses.
 Performance certified is for installation type A - free inlet, free outlet.
 Performance ratings do not include the effects of birdscreen in the airstream.
 The sound ratings shown are loudness values in fan sones @ 5' (1.5m) in a hemispherical free field calculated per AMCA Standard 301. Values shown are for free inlet fan sone levels.



Soler & Palau USA, Div. of Soler & Palau Ventilation Group, certifies that the Models TXB shown herein are licensed to bear the AMCA Seal. The ratings shown are based on test and procedures performed in accordance with AMCA Publication 211 and AMCA Publication 311 and comply with the requirement of the AMCA Certified Ratings Program.



UL STANDARD 705 for Electrical
 UL STANDARD 762 for Grease Removal

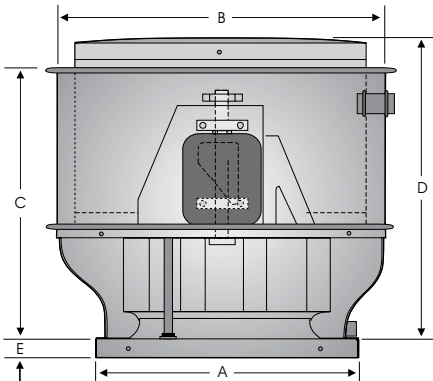

Dimensions (in.)				
A	B	C	D	E
29-1/2	37-3/4	28-1/2	32	2-1/2

Dimensional Data				Metal Thickness			Avg. Ship Wt. (lbs.)
Damper		Roof Opening	Curb OD	Curb Cap	Wind Band	Motor Cover	
ID	OD						
24	24	24-3/4	27-3/4	.080	.050	.050	120

SIZE 18

TXB 18

CFM / BHP @ Static Pressure / Sones													Catalog Number	RPM	HP	Tip Speed
0	1/8	1/4	3/8	1/2	5/8	3/4	1	1-1/4	1-1/2	1-3/4	2					
2339 0.15/7.8	2104 0.16/6.9	1839 0.17/6.3	1497 0.16/5.8	-	-	-	-	-	-	-	-	TXB-18251	650	1/4	3127	
2447 0.17/8.4	2223 0.18/7.5	1975 0.19/7.0	1674 0.19/6.5	-	-	-	-	-	-	-	-	TXB-18252	680	1/4	3271	
2573 0.19/9.1	2360 0.21/8.3	2131 0.22/7.7	1861 0.22/7.2	1476 0.21/6.7	-	-	-	-	-	-	-	TXB-18253	715	1/4	3440	
2681 0.22/9.8	2476 0.23/8.9	2261 0.24/8.3	2011 0.25/7.8	1693 0.25/7.4	-	-	-	-	-	-	-	TXB-18254	745	1/4	3584	
2753 0.24/10.2	2553 0.25/9.4	2346 0.26/8.8	2107 0.27/8.3	1817 0.27/7.8	-	-	-	-	-	-	-	TXB-18331	765	1/3	3680	
2825 0.26/10.6	2630 0.27/9.8	2430 0.28/9.2	2201 0.29/8.7	1932 0.29/8.3	-	-	-	-	-	-	-	TXB-18332	785	1/3	3776	
2879 0.27/11.0	2688 0.29/10.1	2493 0.30/9.5	2271 0.31/9.0	2014 0.31/8.6	1655 0.30/8.1	-	-	-	-	-	-	TXB-18333	800	1/3	3848	
2950 0.29/11.4	2764 0.31/10.5	2576 0.32/9.9	2362 0.33/9.4	2120 0.33/9.0	1807 0.33/8.6	-	-	-	-	-	-	TXB-18334	820	1/3	3945	
3058 0.33/12.1	2879 0.34/11.2	2698 0.35/10.5	2496 0.37/10.1	2271 0.37/9.6	2000 0.37/9.2	-	-	-	-	-	-	TXB-18501	850	1/2	4089	
3166 0.36/12.8	2992 0.38/11.8	2819 0.39/11.1	2628 0.41/10.7	2417 0.41/10.3	2173 0.41/9.8	1844 0.40/9.4	-	-	-	-	-	TXB-18502	880	1/2	4233	
3274 0.40/13.5	3106 0.42/12.6	2939 0.43/11.8	2758 0.45/11.3	2558 0.45/10.9	2334 0.45/10.5	2058 0.45/10.1	-	-	-	-	-	TXB-18503	910	1/2	4378	
3382 0.44/14.1	3219 0.46/13.3	3058 0.47/12.5	2886 0.49/10.0	2696 0.50/11.6	2488 0.50/11.2	2243 0.50/10.8	-	-	-	-	-	TXB-18504	940	1/2	4522	
3472 0.48/14.8	3313 0.49/13.9	3156 0.51/13.2	2991 0.53/12.6	2809 0.54/12.2	2611 0.54/11.7	2386 0.54/11.3	-	-	-	-	-	TXB-18751	965	3/4	4642	
3580 0.52/15.5	3426 0.54/14.6	3274 0.56/13.9	3116 0.57/13.3	2942 0.59/12.9	2755 0.59/12.5	2548 0.59/12.1	-	-	-	-	-	TXB-18752	995	3/4	4786	
3670 0.56/16.1	3519 0.58/15.3	3371 0.60/14.5	3219 0.61/13.9	3052 0.63/13.5	2872 0.64/13.1	2675 0.64/12.7	2160 0.63/11.9	-	-	-	-	TXB-18753	1020	3/4	4907	
3778 0.61/16.9	3631 0.63/16.1	3488 0.65/15.3	3341 0.67/14.6	3181 0.68/14.2	3010 0.70/13.8	2826 0.70/13.4	2372 0.69/12.7	-	-	-	-	TXB-18754	1050	3/4	5051	
3868 0.66/17.5	3725 0.68/16.7	3584 0.70/16.0	3442 0.71/15.3	3288 0.73/14.8	3123 0.74/14.4	2950 0.85/14.0	2786 0.85/13.3	-	-	-	-	TXB-18755	1075	3/4	5171	
4030 0.74/18.7	3892 0.77/17.9	3757 0.79/17.2	3621 0.80/16.5	3478 0.82/16.0	3323 0.84/15.6	3158 0.85/15.2	2786 0.85/14.4	2240 0.82/13.7	-	-	-	TXB-18101	1120	1	5388	
4174 0.83/19.7	4041 0.85/19.0	3910 0.87/18.3	3780 0.89/17.6	3644 0.91/17.1	3497 0.92/16.7	3341 0.94/16.3	2999 0.94/15.7	2558 0.93/14.8	-	-	-	TXB-18102	1160	1	5580	
4318 0.92/21	4189 0.94/20	4063 0.96/19.4	3937 0.98/18.8	3808 1.00/18.2	3668 1.02/17.8	3521 1.03/17.4	3201 1.04/16.6	2816 1.04/15.9	-	-	-	TXB-18103	1200	1	5773	
4498 1.03/22	4374 1.06/22	4253 1.08/21	4132 1.10/20	4009 1.12/19.6	3879 1.14/19.2	3741 1.16/18.8	3444 1.18/18.1	3103 1.18/17.4	2651 1.16/16.7	-	-	TXB-18151	1250	1-1/2	6013	
4678 1.16/24	4558 1.19/23	4442 1.21/22	4326 1.23/22	4208 1.25/21	4087 1.27/21	3957 1.30/20	3678 1.32/19.5	3369 1.33/18.8	2995 1.32/18.2	-	-	TXB-18152	1300	1-1/2	6254	
4857 1.30/25	4742 1.33/24	4630 1.35/24	4518 1.38/23	4406 1.40/23	4291 1.42/22	4169 1.44/22	3906 1.48/21	3621 1.49/20	3292 1.48/19.6	2862 1.46/19	-	TXB-18153	1350	1-1/2	6494	
5037 1.45/27	4926 1.48/26	4818 1.51/25	4710 1.53/25	4602 1.55/24	4492 1.58/24	4377 1.60/23	4129 1.64/23	3862 1.66/22	3566 1.65/21	3208 1.65/21	2665 1.57/20	TXB-18201	1400	2	6735	
5217 1.62/28	5110 1.64/27	5005 1.67/27	4901 1.70/26	4797 1.72/26	4692 1.74/25	4583 1.76/25	4348 1.81/24	4096 1.84/23	3823 1.84/23	3509 1.84/22	3112 1.81/22	TXB-18202	1450	2	6975	
5397 1.79/30	5293 1.82/29	5192 1.85/28	5091 1.87/28	4991 1.90/27	4889 1.92/27	4786 1.94/26	4564 1.99/26	4325 2.03/25	4069 2.04/24	3786 2.04/24	3451 2.03/23	TXB-18203	1500	2	7216	

Power Ratings (BHP) does not include drive losses.
 Performance certified is for installation type A - free inlet, free outlet.
 Performance ratings do not include the effects of birdscreen in the airstream.
 The sound ratings shown are loudness values in fan sones @ 5' (1.5m) in a hemispherical free field calculated per AMCA Standard 301. Values shown are for free inlet fan sone levels.



Soler & Palau USA, Div. of Soler & Palau Ventilation Group, certifies that the Models TXB shown herein are licensed to bear the AMCA Seal. The ratings shown are based on test and procedures performed in accordance with AMCA Publication 211 and AMCA Publication 311 and comply with the requirement of the AMCA Certified Ratings Program.



UL STANDARD 705 for Electrical
 UL STANDARD 762 for Grease Removal

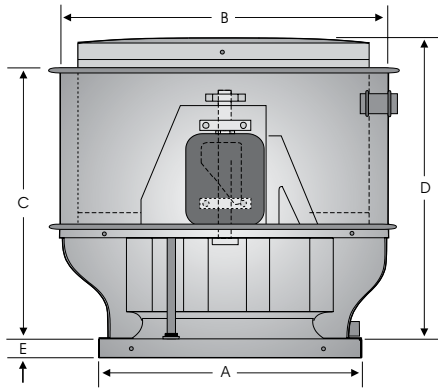

Dimensions (in.)				
A	B	C	D	E
29-1/2	37-3/4	28-1/2	32	2-1/2

Dimensional Data				Metal Thickness			Avg. Ship Wt. (lbs.)
Damper		Roof Opening	Curb OD	Curb Cap	Wind Band	Motor Cover	
ID	OD						
24	24	24-3/4	27-3/4	.080	.050	.050	120

SIZE 18 - HIGH PRESSURE

TXBHP 18

CFM / BHP @ Static Pressure / Sones													RPM	HP	Tip Speed
5/8	3/4	1	1-1/4	1-1/2	1-3/4	2	2-1/4	2-1/2	2-3/4	3	3-1/4	Catalog Number			
1326 0.24/13.1	-	-	-	-	-	-	-	-	-	-	-	TXBHP-18254	805	1/3	3872
1479 0.26/13.5	-	-	-	-	-	-	-	-	-	-	-	TXBHP-18331	825	1/3	3969
1611 0.29/14.0	-	-	-	-	-	-	-	-	-	-	-	TXBHP-18332	845	1/3	4065
1731 0.31/14.5	1293 0.28/14.4	-	-	-	-	-	-	-	-	-	-	TXBHP-18333	865	1/3	4161
1842 0.33/15.0	1480 0.32/14.9	-	-	-	-	-	-	-	-	-	-	TXBHP-18334	885	1/3	4257
2021 0.37/15.9	1729 0.37/15.8	-	-	-	-	-	-	-	-	-	-	TXBHP-18501	920	1/2	4426
2164 0.41/16.7	1910 0.41/16.5	-	-	-	-	-	-	-	-	-	-	TXBHP-18502	950	1/2	4570
2323 0.45/17.8	2099 0.46/17.7	1244 0.38/17.5	-	-	-	-	-	-	-	-	-	TXBHP-18503	985	1/2	4738
2456 0.50/19.4	2249 0.50/19.2	1651 0.47/18.9	-	-	-	-	-	-	-	-	-	TXBHP-18504	1015	1/2	4883
2584 0.54/21	2391 0.55/21	1881 0.53/21	-	-	-	-	-	-	-	-	-	TXBHP-18751	1045	3/4	5027
2707 0.58/23	2527 0.59/23	2076 0.59/22	-	-	-	-	-	-	-	-	-	TXBHP-18752	1075	3/4	5171
2808 0.62/24	2639 0.63/24	2223 0.64/24	-	-	-	-	-	-	-	-	-	TXBHP-18753	1100	3/4	5292
2925 0.67/28	2768 0.68/26	2386 0.69/26	1802 0.65/26	-	-	-	-	-	-	-	-	TXBHP-18754	1130	3/4	5436
3040 0.72/29	2894 0.73/29	2538 0.75/30	2044 0.72/28	-	-	-	-	-	-	-	-	TXBHP-18755	1160	3/4	5580
3206 0.80/33	3076 0.82/35	2753 0.84/32	2340 0.83/32	-	-	-	-	-	-	-	-	TXBHP-18101	1205	1	5797
3388 0.90/40	3270 0.92/40	2980 0.94/37	2623 0.95/39	2120 0.90/39	-	-	-	-	-	-	-	TXBHP-18102	1255	1	6037
3548 1.00/42	3439 1.01/41	3176 1.04/41	2852 1.05/41	2439 1.03/40	-	-	-	-	-	-	-	TXBHP-18103	1300	1	6254
3742 1.12/44	3639 1.14/44	3405 1.17/44	3114 1.19/43	2766 1.19/43	2285 1.14/43	-	-	-	-	-	-	TXBHP-18151	1355	1-1/2	6518
3935 1.25/44	3837 1.27/47	3625 1.31/46	3362 1.33/46	3055 1.35/45	2671 1.32/45	2083 1.22/45	-	-	-	-	-	TXBHP-18152	1410	1-1/2	6783
4126 1.39/49	4032 1.42/49	3837 1.46/49	3600 1.49/48	3321 1.51/48	2995 1.51/48	2568 1.45/48	-	-	-	-	-	TXBHP-18153	1465	1-1/2	7047
4315 1.55/52	4224 1.57/52	4040 1.61/51	3828 1.65/51	3573 1.67/51	3284 1.69/51	2934 1.66/51	2453 1.58/51	-	-	-	-	TXBHP-18201	1520	2	7312
4503 1.71/55	4416 1.74/54	4240 1.78/54	4047 1.82/54	3816 1.85/54	3553 1.87/53	3250 1.87/53	2873 1.83/53	-	-	-	-	TXBHP-18202	1575	2	7576
4690 1.88/57	4606 1.91/57	4437 1.97/56	4259 2.01/56	4049 2.04/56	3806 2.06/56	3537 2.08/56	3219 2.06/56	2813 1.99/56	-	-	-	TXBHP-18203	1630	2	7841
5061 2.27/62	4983 2.30/62	4825 2.36/62	4665 2.41/62	4490 2.45/62	4287 2.49/62	4057 2.51/61	3807 2.53/61	3518 2.52/61	3168 2.46/61	2690 2.34/61	-	TXBHP-183001	1740	3	8370
5428 2.70/68	5356 2.74/68	5208 2.81/68	5059 2.86/68	4906 2.92/68	4735 2.96/68	4540 2.99/68	4323 3.02/68	4090 3.04/68	3829 3.03/68	3522 2.99/68	3141 2.90/68	TXBHP-183002	1850	3	8899

Power Ratings (BHP) does not include drive losses.
 Performance certified is for installation type A - free inlet, free outlet.
 Performance ratings do not include the effects of birdscreen in the airstream.
 The sound ratings shown are loudness values in fan sones @ 5' (1.5m) in a hemispherical free field calculated per AMCA Standard 301. Values shown are for free inlet fan sone levels.



Soler & Palau USA, Div. of Soler & Palau Ventilation Group, certifies that the Models TXB shown herein are licensed to bear the AMCA Seal. The ratings shown are based on test and procedures performed in accordance with AMCA Publication 211 and AMCA Publication 311 and comply with the requirement of the AMCA Certified Ratings Program.



UL STANDARD 705 for Electrical
UL STANDARD 762 for Grease Removal

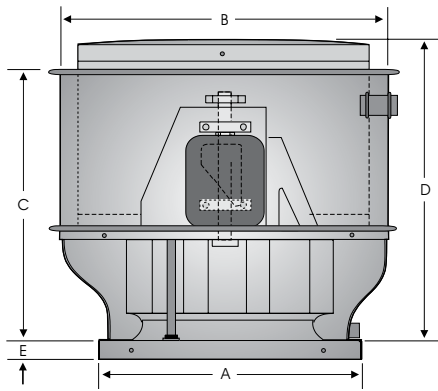

Dimensions (in.)				
A	B	C	D	E
29-1/2	37-3/4	28-1/2	32	2-1/2

Dimensional Data				Metal Thickness			Avg. Ship Wt. (lbs.)
Damper		Roof Opening	Curb OD	Curb Cap	Wind Band	Motor Cover	
ID	OD						
24	24	24-3/4	27-3/4	.063	.050	.050	120

SIZE 20

TXB 20

Performance/Dimensional Data

CFM / BHP @ Static Pressure / Sones													RPM	HP	Tip Speed
0	1/8	1/4	3/8	1/2	5/8	3/4	7/8	1	1-1/4	1-1/2	1-3/4	Catalog Number			
2813 0.15/7.6	2452 0.16/6.7	1962 0.17/6.4	-	-	-	-	-	-	-	-	-	TXB-20251	525	1/4	2935
3322 0.24/10.3	3023 0.26/9.4	2684 0.27/8.9	2182 0.27/8.7	1366 0.22/8.6	-	-	-	-	-	-	-	TXB-20252	620	1/4	3466
3429 0.26/10.7	3140 0.28/9.8	2818 0.30/9.3	2376 0.30/9.1	1660 0.26/9.0	-	-	-	-	-	-	-	TXB-20331	640	1/3	3578
3617 0.31/11.4	3345 0.33/10.6	3045 0.35/10.0	2676 0.36/9.8	2087 0.33/9.7	1191 0.26/9.5	-	-	-	-	-	-	TXB-20332	675	1/3	3773
3777 0.35/11.9	3518 0.38/11.2	3235 0.39/10.6	2906 0.41/10.4	2407 0.39/10.2	1708 0.34/10.0	-	-	-	-	-	-	TXB-20501	705	1/2	3941
3965 0.41/12.8	3719 0.43/12	3452 0.45/11.4	3155 0.47/11.2	2753 0.46/11.0	2165 0.43/10.8	1318 0.35/10.6	-	-	-	-	-	TXB-20502	740	1/2	4137
4152 0.47/13.7	3919 0.49/13.2	3666 0.52/12.5	3392 0.53/12.2	3054 0.54/12.0	2554 0.51/11.8	1910 0.46/11.6	-	-	-	-	-	TXB-20503	775	1/2	4332
4286 0.52/14.4	4060 0.54/13.8	3817 0.56/13.4	3557 0.58/13.0	3250 0.59/12.7	2813 0.58/12.6	2242 0.53/12.4	1439 0.44/12.1	-	-	-	-	TXB-20751	800	3/4	4472
4420 0.57/15.2	4202 0.59/14.6	3967 0.62/14.0	3718 0.64/13.7	3436 0.65/13.6	3056 0.64/13.3	2537 0.60/13.1	1883 0.54/12.9	-	-	-	-	TXB-20752	825	3/4	4612
4554 0.62/16.0	4343 0.65/15.4	4116 0.67/14.8	3877 0.69/14.4	3612 0.71/14.2	3278 0.71/14.2	2809 0.68/14	2241 0.62/13.8	1423 0.51/13.6	-	-	-	TXB-20753	850	3/4	4752
4688 0.68/16.9	4483 0.70/16.3	4264 0.73/15.7	4034 0.75/15.2	3784 0.77/15.0	3482 0.77/14.8	3067 0.75/14.6	2554 0.71/14.3	1902 0.63/14.1	-	-	-	TXB-20754	875	3/4	4891
4849 0.75/17.8	4651 0.78/17.3	4441 0.80/16.7	4220 0.83/16.2	3984 0.85/16.0	3713 0.86/15.6	3359 0.85/15.6	2894 0.81/15.3	2346 0.75/15.1	-	-	-	TXB-20101	905	1	5059
5037 0.84/18.9	4846 0.87/18.4	4645 0.90/17.9	4434 0.92/17.4	4212 0.94/17.1	3967 0.96/16.9	3665 0.96/16.8	3261 0.93/16.4	2785 0.88/16.1	-	-	-	TXB-20102	940	1	5255
5224 0.93/20	5041 0.96/19.6	4848 1.00/19.1	4646 1.02/18.5	4436 1.05/18.2	4208 1.07/18	3944 1.07/17.9	3605 1.06/17.7	3175 1.02/17.5	2072 0.86/17.1	-	-	TXB-20103	975	1	5450
5412 1.04/22	5235 1.07/21	5050 1.10/21	4856 1.13/19.8	4656 1.16/19.3	4442 1.18/19.2	4205 1.19/19.0	3915 1.19/18.9	3538 1.16/18.8	2598 1.03/18.5	-	-	TXB-20151	1010	1-1/2	5646
5599 1.15/23	5429 1.18/22	5251 1.22/22	5065 1.25/21	4873 1.27/21	4671 1.30/20	4452 1.32/20	4197 1.32/20	3879 1.30/20	3043 1.20/19.3	-	-	TXB-20152	1045	1-1/2	5842
5787 1.27/24	5622 1.30/24	5451 1.34/23	5272 1.37/23	5087 1.40/22	4895 1.42/22	4690 1.45/22	4462 1.46/21	4187 1.45/21	3441 1.37/21	-	-	TXB-20153	1080	1-1/2	6037
5974 1.40/26	5815 1.43/25	5649 1.47/24	5477 1.50/24	5300 1.53/23	5116 1.56/23	4923 1.58/23	4713 1.60/23	4470 1.60/23	3808 1.55/22	-	-	TXB-20154	1115	1-1/2	6233
6162 1.53/27	6008 1.57/26	5848 1.60/26	5682 1.64/25	5510 1.67/25	5335 1.70/24	5151 1.73/24	4954 1.75/24	4736 1.76/24	4163 1.72/23	-	-	TXB-20201	1150	2	6429
6296 1.64/28	6145 1.67/28	5989 1.71/27	5827 1.75/26	5660 1.78/26	5489 1.81/25	5311 1.83/25	5123 1.86/25	4918 1.88/25	4398 1.85/25	-	-	TXB-20202	1175	2	6568
6430 1.74/29	6282 1.78/29	6130 1.82/28	5972 1.85/27	5809 1.89/27	5642 1.92/26	5470 1.95/26	5289 1.97/26	5094 2.00/26	4618 1.99/26	-	-	TXB-20203	1200	2	6708
6564 1.85/30	6419 1.89/30	6270 1.93/29	6116 1.97/28	5957 2.00/28	5795 2.04/27	5627 2.07/27	5452 2.09/27	5267 2.12/27	4825 2.12/26	-	-	TXB-20204	1225	2	6848

Power Ratings (BHP) does not include drive losses.
 Performance certified is for installation type A - free inlet, free outlet.
 Performance ratings do not include the effects of birdscreen in the airstream.
 The sound ratings shown are loudness values in fan sones @ 5' (1.5m) in a hemispherical free field calculated per AMCA Standard 301. Values shown are for free inlet fan sone levels.



Soler & Palau USA, Div. of Soler & Palau Ventilation Group, certifies that the Models TXB shown herein are licensed to bear the AMCA Seal. The ratings shown are based on test and procedures performed in accordance with AMCA Publication 211 and AMCA Publication 311 and comply with the requirement of the AMCA Certified Ratings Program.



UL STANDARD 705 for Electrical
 UL STANDARD 762 for Grease Removal

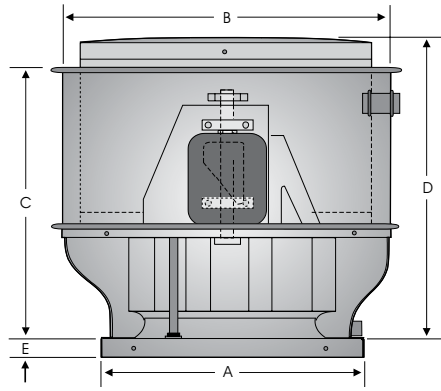

Dimensions (in.)				
A	B	C	D	E
29-1/2	37-3/4	28-1/2	32	2-1/2

Dimensional Data				Metal Thickness			Avg. Ship Wt. (lbs.)
Damper		Roof Opening	Curb OD	Curb Cap	Wind Band	Motor Cover	
ID	OD						
24	24	24-3/4	27-3/4	.080	.050	.050	120

SIZE 20 - HIGH PRESSURE

TXBHP 20

CFM / BHP @ Static Pressure / Sones													RPM	HP	Tip Speed
3/8	1/2	5/8	3/4	7/8	1	1-1/4	1-1/2	1-3/4	2	2-1/4	2-1/2	Catalog Number			
2313 0.30/9.4	1909 0.29/8.3	1373 0.26/7.4	-	-	-	-	-	-	-	-	-	TXBHP-20501	700	1/2	3940
2612 0.36/10.4	2286 0.36/9.6	1858 0.35/8.7	1316 0.31/8.0	-	-	-	-	-	-	-	-	TXBHP-20502	750	1/2	4222
2890 0.44/11.5	2619 0.44/10.7	2272 0.44/10.0	1837 0.41/9.3	1301 0.37/8.7	-	-	-	-	-	-	-	TXBHP-20503	800	1/2	4503
3156 0.52/12.7	2923 0.53/11.9	2635 0.53/11.2	2279 0.52/10.5	1848 0.49/9.9	1324 0.44/9.4	-	-	-	-	-	-	TXBHP-20504	850	1/2	4784
3284 0.57/13.4	3067 0.58/12.7	2803 0.58/12.0	2478 0.57/11.4	2086 0.55/10.7	1622 0.51/10.2	-	-	-	-	-	-	TXBHP-20751	875	3/4	4925
3437 0.63/14.6	3235 0.64/13.8	2994 0.64/13.1	2703 0.64/12.4	2352 0.62/11.8	1938 0.59/11.2	-	-	-	-	-	-	TXBHP-20752	905	3/4	5094
3586 0.69/15.8	3398 0.70/15.0	3177 0.71/14.3	2913 0.71/13.6	2598 0.69/12.9	2227 0.67/12.3	1268 0.55/11.4	-	-	-	-	-	TXBHP-20753	935	3/4	5263
3734 0.75/16.9	3558 0.77/16.2	3353 0.78/15.5	3112 0.78/14.8	2828 0.77/14.1	2493 0.75/13.5	1661 0.66/12.3	-	-	-	-	-	TXBHP-20754	965	3/4	5432
4000 0.88/19.2	3842 0.90/18.6	3662 0.91/17.8	3455 0.92/17.1	3215 0.92/16.4	2936 0.91/15.7	2248 0.85/14.4	1324 0.71/13.6	-	-	-	-	TXBHP-20101	1020	1	5741
4238 1.01/21	4093 1.03/21	3931 1.05/20	3747 1.06/19.4	3538 1.06/18.7	3298 1.06/18.0	2710 1.02/16.5	1968 0.93/15.3	-	-	-	-	TXBHP-20102	1070	1	6023
4427 1.13/23	4290 1.15/23	4139 1.17/22	3971 1.18/21	3781 1.18/21	3566 1.18/20	3045 1.16/18.5	2390 1.09/17.1	1555 0.94/16.2	-	-	-	TXBHP-20151	1110	1-1/2	6248
4614 1.25/25	4485 1.27/25	4344 1.29/24	4188 1.30/24	4014 1.31/23	3820 1.32/22	3354 1.30/20	2772 1.25/19.0	2061 1.14/17.6	-	-	-	TXBHP-20152	1150	1-1/2	6473
4799 1.38/28	4677 1.40/27	4545 1.42/27	4400 1.44/26	4240 1.45/25	4062 1.46/24	3643 1.45/23	3122 1.41/21	2492 1.33/19.6	1710 1.17/18.6	-	-	TXBHP-20153	1190	1-1/2	6698
4960 1.50/30	4844 1.52/29	4718 1.55/29	4581 1.56/28	4431 1.58/27	4266 1.59/27	3881 1.59/25	3408 1.56/23	2835 1.49/21	2153 1.37/20	1120 1.05/19.8	-	TXBHP-20154	1225	1-1/2	6895
5167 1.66/32	5057 1.69/31	4938 1.71/31	4810 1.74/31	4672 1.75/30	4520 1.77/29	4172 1.77/27	3750 1.76/26	3241 1.70/24	2642 1.61/22	1920 1.77/21	-	TXBHP-20201	1270	2	7148
5349 1.82/33	5244 1.85/33	5131 1.87/32	5011 1.90/32	4880 1.92/31	4739 1.93/30	4419 1.95/29	4035 1.94/27	3576 1.90/26	3034 1.82/24	2405 1.70/22	1596 1.46/22	TXBHP-20202	1310	2	7374
5531 1.98/34	5430 2.01/34	5323 2.04/34	5208 2.07/34	5086 2.09/33	4954 2.11/32	4656 2.13/31	4305 2.13/29	3888 2.10/27	3398 2.04/26	2832 1.94/24	2170 1.44/23	TXBHP-20203	1350	2	7599
5712 2.16/35	5615 2.19/35	5512 2.22/35	5404 2.25/35	5287 2.27/34	5163 2.29/33	4886 2.32/32	4563 2.33/30	4183 2.31/29	3737 2.26/27	3223 2.18/26	2637 2.05/24	TXBHP-20301	1390	3	7824
5869 2.32/36	5776 2.35/36	5677 2.38/36	5573 2.41/35	5462 2.44/35	5344 2.46/34	5082 2.49/33	4780 2.51/31	4428 2.50/30	4017 2.46/28	3543 2.39/27	3005 2.28/26	TXBHP-20302	1425	3	8021
6027 2.49/37	5936 2.52/37	5841 2.56/36	5741 2.59/36	5635 2.61/36	5522 2.64/35	5274 2.68/34	4990 2.69/33	4662 2.69/31	4283 2.66/30	3845 2.61/28	3349 2.51/27	TXBHP-20303	1460	3	8218
6184 2.67/38	6096 2.70/38	6004 2.74/37	5908 2.77/37	5806 2.80/37	5698 2.82/36	5462 2.86/35	5195 2.89/34	4888 2.89/32	4536 2.88/32	4131 2.83/30	3672 2.75/29	TXBHP-20304	1495	3	8415
6340 2.85/38	6255 2.89/38	6167 2.92/38	6073 2.96/38	5975 2.99/38	5872 3.02/37	5647 3.06/36	5394 3.09/35	5107 3.10/34	4779 3.09/32	4403 3.06/31	3977 2.99/30	TXBHP-20305	1530	3	8612

Power Ratings (BHP) does not include drive losses.
 Performance certified is for installation type A - free inlet, free outlet.
 Performance ratings do not include the effects of birdscreen in the airstream.
 The sound ratings shown are loudness values in fan sones @ 5' (1.5m) in a hemispherical free field calculated per AMCA Standard 301. Values shown are for free inlet fan sone levels.



Soler & Palau USA, Div. of Soler & Palau Ventilation Group, certifies that the Models TXB shown herein are licensed to bear the AMCA Seal. The ratings shown are based on test and procedures performed in accordance with AMCA Publication 211 and AMCA Publication 311 and comply with the requirement of the AMCA Certified Ratings Program.



UL STANDARD 705 for Electrical
UL STANDARD 762 for Grease Removal

Performance/Dimensional Data

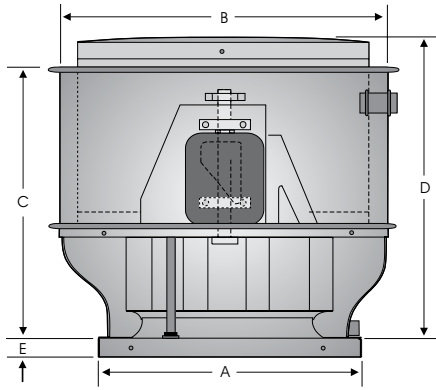

Dimensions (in.)				
A	B	C	D	E
35-1/2	47-1/4	31-1/2	42	2-1/2

Dimensional Data		Metal Thickness				Avg. Ship Wt. (lbs.)	
Damper	Roof Opening	Curb OD	Curb Cap	Wind Band	Motor Cover		
ID	OD						
30	30	30-3/4	33-3/4	.10	.050	.050	245

SIZE 24

TXB 24

Performance/Dimensional Data

CFM / BHP @ Static Pressure / Sones													Catalog Number	RPM	HP	Tip Speed
0	1/8	1/4	3/8	1/2	5/8	3/4	1	1-1/4	1-1/2	1-3/4	2					
3681 0.15/7.3	3200 0.17/6.0	2377 0.17/4.6	-	-	-	-	-	-	-	-	-	-	TXB-24251	400	1/4	2566
4141 0.22/9.1	3728 0.24/7.8	3170 0.25/6.4	-	-	-	-	-	-	-	-	-	-	TXB-24252	450	1/4	2886
4371 0.26/9.8	3985 0.29/8.5	3490 0.29/7.3	2537 0.27/6.0	-	-	-	-	-	-	-	-	-	TXB-24331	475	1/3	3047
4555 0.29/10.3	4188 0.32/9.2	3731 0.33/8.0	3018 0.33/6.8	-	-	-	-	-	-	-	-	-	TXB-24332	495	1/3	3175
4601 0.30/10.4	4238 0.33/9.3	3789 0.34/8.2	3114 0.34/6.9	-	-	-	-	-	-	-	-	-	TXB-24501	500	1/2	3207
4831 0.35/11.1	4488 0.38/10.0	4077 0.40/9.0	3516 0.40/7.8	2235 0.34/6.8	-	-	-	-	-	-	-	-	TXB-24502	525	1/2	3367
5015 0.39/11.6	4687 0.42/10.6	4300 0.44/9.7	3800 0.44/8.5	2825 0.41/7.6	-	-	-	-	-	-	-	-	TXB-24503	545	1/2	3496
5199 0.44/12.2	4884 0.47/11.2	4519 0.49/10.3	4063 0.50/9.2	3346 0.48/8.3	-	-	-	-	-	-	-	-	TXB-24504	565	1/2	3624
5291 0.46/12.6	4982 0.49/11.5	4626 0.52/10.6	4190 0.52/9.5	3552 0.52/8.6	1261 0.28/7.8	-	-	-	-	-	-	-	TXB-24751	575	3/4	3688
5705 0.58/14.3	5421 0.61/13.3	5103 0.64/12.4	4730 0.65/11.4	4259 0.66/10.4	3462 0.62/9.5	-	-	-	-	-	-	-	TXB-24752	620	3/4	3977
5935 0.65/15.4	5663 0.69/14.3	5362 0.72/13.4	5016 0.73/12.6	4596 0.74/11.4	4012 0.73/10.5	2813 0.63/9.6	-	-	-	-	-	-	TXB-24753	645	3/4	4137
5981 0.66/15.6	5712 0.70/14.5	5413 0.73/13.6	5072 0.75/12.8	4661 0.75/11.6	4099 0.75/10.7	2979 0.66/9.8	-	-	-	-	-	-	TXB-24754	650	3/4	4169
6212 0.74/16.6	5953 0.79/15.6	5669 0.82/14.7	5349 0.84/13.7	4975 0.84/12.8	4498 0.84/11.8	3680 0.79/10.8	-	-	-	-	-	-	TXB-24101	675	1	4329
6396 0.81/17.4	6145 0.86/16.5	5871 0.89/15.6	5567 0.91/14.7	5216 0.92/13.6	4787 0.92/12.6	4163 0.90/11.7	-	-	-	-	-	-	TXB-24102	695	1	4458
6580 0.88/18.4	6336 0.93/17.3	6073 0.97/16.4	5782 0.99/15.6	5451 1.00/14.6	5058 1.00/13.5	4541 1.00/12.6	-	-	-	-	-	-	TXB-24103	715	1	4586
6626 0.90/18.6	6384 0.95/17.6	6123 0.98/16.6	5835 1.01/15.8	5509 1.02/14.8	5124 1.03/13.7	4623 1.02/12.8	-	-	-	-	-	-	TXB-24104	720	1	4618
6856 1.00/19.8	6623 1.05/18.8	6373 1.09/17.8	6099 1.11/16.9	5794 1.13/16.0	5442 1.13/14.9	5011 1.14/13.9	3256 0.97/12.2	-	-	-	-	-	TXB-24151	745	1-1/2	4778
7178 1.15/21	6956 1.120/20	6720 1.24/19.5	6464 1.27/18.6	6183 1.29/17.7	5867 1.30/16.7	5498 1.30/15.6	4265 1.22/13.8	-	-	-	-	-	TXB-24152	780	1-1/2	5003
7362 1.24/23	7146 1.29/21	6917 1.33/21	6670 1.37/19.6	6401 1.39/18.7	6102 1.40/17.7	5759 1.41/16.6	4754 1.37/14.7	-	-	-	-	-	TXB-24153	800	1-1/2	5131
7546 1.33/24	7336 1.39/23	7113 1.43/22	6874 1.47/21	6616 1.49/19.7	6332 1.15/18.7	6010 1.51/17.6	5146 1.50/15.7	2245 0.93/14.0	-	-	-	-	TXB-24154	820	1-1/2	5259
7730 1.43/25	7525 1.49/24	7309 1.54/23	7078 1.57/22	6829 1.60/21	6557 1.62/19.8	6254 1.63/18.7	5477 1.62/16.7	3873 1.43/15.0	-	-	-	-	TXB-24201	840	2	5388
7960 1.56/26	7761 1.62/25	7552 1.67/24	7330 1.71/23	7092 1.74/22	6835 1.76/21	6552 1.77/20	5854 1.78/18	4566 1.63/16.2	-	-	-	-	TXB-24202	865	2	5548
8098 1.65/27	7903 1.71/26	7698 1.76/25	7481 1.80/24	7249 1.83/23	6999 1.85/22	6726 1.87/21	6067 1.87/18.8	4977 1.78/17.0	-	-	-	-	TXB-24203	880	2	5644
8282 1.76/28	8091 1.82/27	7892 1.87/26	7681 1.92/24	7457 1.95/23	7216 1.98/23	6956 1.99/22	6339 2.00/19.8	5433 1.96/18.0	-	-	-	-	TXB-24204	900	2	5773
8742 2.07/30	8562 2.14/29	8374 2.19/28	8178 2.24/27	7970 2.28/26	7750 2.31/25	7514 2.33/24	6979 2.35/22	6292 2.35/20	5073 2.18/18.8	-	-	-	TXB-24301	950	3	6093
9432 2.60/32	9266 2.67/32	9093 2.74/31	8914 2.79/30	8727 2.84/29	8531 2.88/28	8324 2.91/28	7869 2.95/26	7334 2.96/24	6649 2.95/23	5447 2.73/21	-	-	TXB-24302	1025	3	6574

Power Ratings (BHP) does not include drive losses.
 Performance certified is for installation type A - free inlet, free outlet.
 Performance ratings do not include the effects of birdscreen in the airstream.
 The sound ratings shown are loudness values in fan sones @ 5' (1.5m) in a hemispherical free field calculated per AMCA Standard 301. Values shown are for free inlet fan sone levels.



Soler & Palau USA, Div. of Soler & Palau Ventilation Group, certifies that the Models TXB shown herein are licensed to bear the AMCA Seal. The ratings shown are based on test and procedures performed in accordance with AMCA Publication 211 and AMCA Publication 311 and comply with the requirement of the AMCA Certified Ratings Program.



UL STANDARD 705 for Electrical
UL STANDARD 762 for Grease Removal

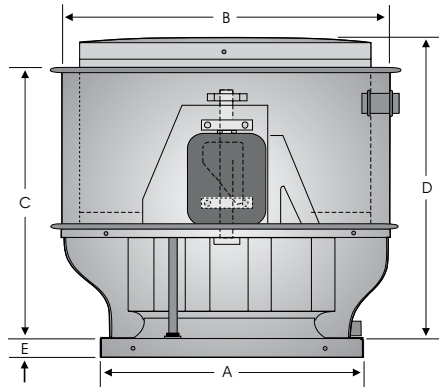

Dimensions (in.)				
A	B	C	D	E
35-1/2	47-1/4	31-1/2	42	2-1/2

Dimensional Data				Metal Thickness			Avg. Ship Wt. (lbs.)
Damper		Roof Opening	Curb OD	Curb Cap	Wind Band	Motor Cover	
ID	OD						
30	30	30-3/4	33-3/4	.10	.050	.050	245

SIZE 24 - HIGH PRESSURE

TXBHP 24

CFM / BHP @ Static Pressure / Sones													RPM	HP	Tip Speed
1/2	5/8	3/4	1	1-1/4	1-1/2	1-3/4	2	2-1/4	2-1/2	2-3/4	3	Catalog Number			
2564 0.37/6.8	-	-	-	-	-	-	-	-	-	-	-	TXBHP-24501	580	1/2	3720
3218 0.46/8.2	1910 0.38/7.2	-	-	-	-	-	-	-	-	-	-	TXBHP-24503	620	1/2	3977
3487 0.51/9.0	2680 0.48/7.8	-	-	-	-	-	-	-	-	-	-	TXBHP-24504	640	1/2	4105
3793 0.57/9.9	3170 0.56/8.8	-	-	-	-	-	-	-	-	-	-	TXBHP-24751	665	3/4	4265
4018 0.62/10.6	3481 0.62/9.5	2423 0.55/8.5	-	-	-	-	-	-	-	-	-	TXBHP-24752	685	3/4	4394
4495 0.74/12.7	4079 0.75/11.3	3498 0.74/10.2	-	-	-	-	-	-	-	-	-	TXBHP-24754	730	3/4	4682
4697 0.80/13.4	4315 0.82/12.2	3808 0.81/11.0	-	-	-	-	-	-	-	-	-	TXBHP-24101	750	1	4810
4896 0.87/14.2	4538 0.88/13.0	4089 0.89/11.8	-	-	-	-	-	-	-	-	-	TXBHP-24102	770	1	4939
5092 0.93/15.0	4753 0.95/13.9	4349 0.96/12.8	2752 0.84/10.8	-	-	-	-	-	-	-	-	TXBHP-24103	790	1	5067
5285 1.00/15.8	4962 1.02/14.8	4593 1.03/13.6	3401 0.98/11.6	-	-	-	-	-	-	-	-	TXBHP-24104	810	1	5195
5570 1.11/17.0	5267 1.13/16.2	4933 1.14/15.0	3991 1.13/12.9	-	-	-	-	-	-	-	-	TXBHP-24151	840	1-1/2	5388
5855 1.22/18.3	5563 1.25/17.4	5255 1.26/16.3	4455 1.27/14.2	-	-	-	-	-	-	-	-	TXBHP-24152	870	1-1/2	5580
6088 1.32/19.3	5806 1.35/18.5	5515 1.37/17.5	4800 1.39/15.3	3525 1.29/13.6	-	-	-	-	-	-	-	TXBHP-24153	895	1-1/2	5740
6364 1.44/21	6094 1.48/19.8	5818 1.51/18.9	5180 1.53/16.7	4210 1.49/14.8	-	-	-	-	-	-	-	TXBHP-24154	925	1-1/2	5933
6591 1.55/22	6331 1.60/21	6065 1.62/20	5473 1.66/17.9	4639 1.64/15.9	-	-	-	-	-	-	-	TXBHP-24201	950	2	6093
6816 1.67/23	6567 1.71/22	6308 1.75/21	5751 1.79/19.1	5014 1.79/17.1	3684 1.64/15.7	-	-	-	-	-	-	TXBHP-24202	975	2	6254
6993 1.77/24	6754 1.81/23	6501 1.85/22	5967 1.89/20	5291 1.91/18.1	4234 1.83/16.4	-	-	-	-	-	-	TXBHP-24203	995	2	6382
7214 1.89/25	6985 1.94/24	6739 1.98/23	6229 2.03/21	5616 2.06/19.3	4735 2.01/17.5	-	-	-	-	-	-	TXBHP-24204	1020	2	6542
7822 2.28/29	7619 2.33/28	7399 2.38/27	6934 2.46/25	6429 2.50/23	5797 2.51/21	4895 2.44/19.3	-	-	-	-	-	TXBHP-24301	1090	3	6991
8460 2.75/34	8281 2.81/32	8086 2.86/31	7660 2.96/29	7217 3.02/27	6720 3.06/25	6093 2.97/21	5228 2.97/21	2739 2.09/21	-	-	-	TXBHP-24302	1165	3	7472
9338 3.53/38	9183 3.58/36	9017 3.64/35	8646 3.76/33	8253 3.86/31	7843 3.96/30	7390 3.96/28	6845 3.97/27	6151 3.92/25	5107 3.73/24	-	-	TXBHP-245001	1270	5	8146
10248 4.48/42	10108 4.54/41	9964 4.60/40	9649 4.73/38	9298 4.86/36	8932 4.96/35	8555 5.02/33	8146 5.07/32	7678 5.09/30	7107 5.08/29	6392 4.98/28	5248 4.67/27	TXBHP-245002	1380	5	8851

Power Ratings (BHP) does not include drive losses.
 Performance certified is for installation type A - free inlet, free outlet.
 Performance ratings do not include the effects of birdscreen in the airstream.
 The sound ratings shown are loudness values in fan sones @ 5' (1.5m) in a hemispherical free field calculated per AMCA Standard 301. Values shown are for free inlet fan sone levels.



Soler & Palau USA, Div. of Soler & Palau Ventilation Group, certifies that the Models TXB shown herein are licensed to bear the AMCA Seal. The ratings shown are based on test and procedures performed in accordance with AMCA Publication 211 and AMCA Publication 311 and comply with the requirement of the AMCA Certified Ratings Program.



UL STANDARD 705 for Electrical
 UL STANDARD 762 for Grease Removal

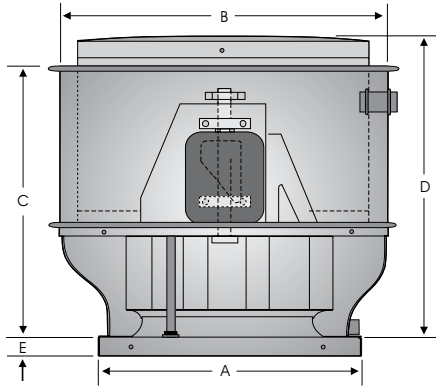

Dimensions (in.)				
A	B	C	D	E
42-1/2	56-3/4	41	45	2-1/2

Dimensional Data				Metal Thickness			Avg. Ship Wt. (lbs.)
Damper		Roof	Curb	Curb	Wind	Motor	
ID	OD	Opening	OD	Cap	Band	Cover	
36	36	37-3/4	40-3/4	.090	.050	.050	365

SIZE 30

TXB 30

CFM / BHP @ Static Pressure / Sones													RPM	HP	Tip Speed
1/8	1/4	3/8	1/2	5/8	3/4	1	1-1/4	1-1/2	1-3/4	2	2-1/4	Catalog Number			
3720 0.16/3.8	-	-	-	-	-	-	-	-	-	-	-	TXB-30331	280	1/3	2236
4477 0.23/4.9	-	-	-	-	-	-	-	-	-	-	-	TXB-30332	315	1/3	2515
5280 0.32/6.2	4249 0.34/5.8	-	-	-	-	-	-	-	-	-	-	TXB-30333	355	1/3	2835
5572 0.36/6.7	4639 0.38/6.3	-	-	-	-	-	-	-	-	-	-	TXB-30501	370	1/2	2954
5860 0.41/7.2	5005 0.43/6.8	3594 0.41/6.3	-	-	-	-	-	-	-	-	-	TXB-30502	385	1/2	3074
6240 0.47/7.9	5466 0.50/7.5	4315 0.49/7.1	-	-	-	-	-	-	-	-	-	TXB-30503	405	1/2	3234
6615 0.54/8.6	5902 0.57/8.2	4931 0.58/7.8	3194 0.51/7.2	-	-	-	-	-	-	-	-	TXB-30751	425	3/4	3394
6987 0.62/9.3	6322 0.65/8.9	5474 0.67/8.5	4167 0.63/8.1	-	-	-	-	-	-	-	-	TXB-30752	445	3/4	3553
7356 0.70/10.0	6730 0.74/9.6	5973 0.76/9.3	4894 0.74/9.0	-	-	-	-	-	-	-	-	TXB-30753	465	3/4	3713
7631 0.77/10.7	7032 0.81/10.2	6328 0.83/9.8	5375 0.83/9.6	3866 .075/8.9	-	-	-	-	-	-	-	TXB-30101	480	1	3833
7904 0.84/11.3	7328 0.88/10.8	6671 0.91/10.4	5814 0.91/10.2	4598 0.86/9.7	-	-	-	-	-	-	-	TXB-30102	495	1	3952
8176 0.91/11.9	7622 0.96/11.5	7003 0.99/11.1	6221 1.00/10.7	5125 0.97/10.4	-	-	-	-	-	-	-	TXB-30103	510	1	4072
8628 1.05/13.1	8106 1.10/12.6	7534 1.13/12.2	6850 1.15/11.7	5959 1.15/11.5	4685 1.07/10.9	-	-	-	-	-	-	TXB-30151	535	1-1/2	4272
9078 1.20/14.2	8583 1.25/13.8	8050 1.29/13.3	7440 1.32/12.8	6682 1.32/12.5	5662 1.29/12.1	-	-	-	-	-	-	TXB-30152	560	1-1/2	4471
9525 1.36/15.3	9055 1.42/14.8	8555 1.46/14.4	8001 1.50/14.0	7334 1.51/13.6	6495 1.50/13.2	-	-	-	-	-	-	TXB-30153	585	1-1/2	4671
9881 1.50/16.2	9429 1.56/15.7	8951 1.61/15.2	8431 1.65/14.8	7824 1.67/14.4	7087 1.67/14.2	4766 1.50/13.1	-	-	-	-	-	TXB-30201	605	2	4831
10325 1.69/17.3	9894 1.75/16.8	9440 1.80/16.4	8954 1.85/15.9	8407 1.88/15.6	7758 1.89/15.2	5919 1.79/14.4	-	-	-	-	-	TXB-30202	630	2	5030
10680 1.85/18.1	10263 1.91/17.7	9827 1.97/17.3	9364 2.02/16.9	8855 2.05/16.5	8262 2.07/16.1	6658 2.02/15.4	-	-	-	-	-	TXB-30203	650	2	5190
11122 2.07/19.3	10721 2.13/18.8	10306 2.19/18.4	9868 2.25/18.1	9397 2.29/17.7	8860 2.31/17.3	7484 2.30/16.7	5245 2.08/15.6	-	-	-	-	TXB-30301	675	3	5390
11650 2.35/20	11268 2.42/20	10874 2.48/19.8	10462 2.54/19.5	10024 2.59/19.1	9545 2.62/18.8	8360 2.64/18.1	6643 2.52/17.2	-	-	-	-	TXB-30302	705	3	5629
12177 2.66/22	11812 2.73/22	11437 2.80/21	11047 2.86/20	10637 2.91/21	10199 2.96/20	9152 3.00/19.6	7730 2.94/19.0	5454 2.65/18.1	-	-	-	TXB-30303	735	3	5869
12966 3.17/24	12623 3.24/24	12273 3.32/23	11911 3.39/23	11535 3.45/23	11140 3.50/22	10244 3.57/22	9119 3.57/21	7571 3.44/21	-	-	-	TXB-305001	780	5	6228
13839 3.80/26	13518 3.89/26	13191 3.97/26	12856 4.04/25	12511 4.11/25	12152 4.17/25	11374 4.27/25	10439 4.32/24	9268 4.28/23	7696 4.09/23	-	-	TXB-305002	830	5	6627
14623 4.44/29	14319 4.53/28	14011 4.62/28	13696 4.70/27	13373 4.78/27	13040 4.85/27	12332 4.96/27	11522 5.04/26	10552 5.05/26	9325 4.97/25	7711 4.71/25	-	TXB-305003	875	5	6987
15752 5.50/32	15471 5.59/32	15185 5.69/31	14895 5.78/31	14599 5.86/30	14296 5.94/30	13661 6.08/30	12977 6.19/30	12187 6.26/29	11261 6.26/29	10120 6.17/29	8680 5.93/28	TXB-307501	940	7-1/2	7506
16792 6.60/36	16528 6.71/35	16261 6.81/35	15990 6.90/34	15715 7.00/34	15434 7.09/34	14854 7.25/34	14238 7.38/33	13564 7.49/33	12794 7.54/33	11905 7.54/32	10831 7.44/32	TXB-307502	1000	7-1/2	7985

Power Ratings (BHP) does not include drive losses.
 Performance certified is for installation type A - free inlet, free outlet.
 Performance ratings do not include the effects of birdscreen in the airstream.
 The sound ratings shown are loudness values in fan sones @ 5' (1.5m) in a hemispherical free field calculated per AMCA Standard 301. Values shown are for free inlet fan sone levels.



Soler & Palau USA, Div. of Soler & Palau Ventilation Group, certifies that the Models TXB shown herein are licensed to bear the AMCA Seal. The ratings shown are based on test and procedures performed in accordance with AMCA Publication 211 and AMCA Publication 311 and comply with the requirement of the AMCA Certified Ratings Program.



UL STANDARD 705 for Electrical
 UL STANDARD 762 for Grease Removal

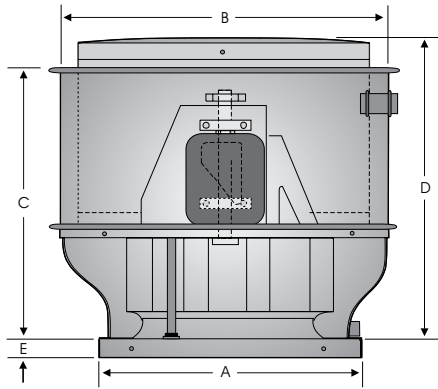

Dimensions (in.)				
A	B	C	D	E
42-1/2	56-3/4	41	45	2-1/2

Dimensional Data				Metal Thickness			Avg. Ship Wt. (lbs.)
Damper		Roof Opening	Curb OD	Curb Cap	Wind Band	Motor Cover	
ID	OD						
36	36	37-3/4	40-3/4	.090	.050	.050	365

SIZE 30 - HIGH PRESSURE

TXBHP 30

Performance/Dimensional Data

CFM / BHP @ Static Pressure / Sones													RPM	HP	Tip Speed
1/4	3/8	1/2	5/8	3/4	1	1-1/4	1-1/2	1-3/4	2	2-1/4	2-1/2	Catalog Number			
3328 0.24/4.3	-	-	-	-	-	-	-	-	-	-	-	TXBHP-30332	345	1/3	2755
4276 0.34/ 5.5	-	-	-	-	-	-	-	-	-	-	-	TXBHP-30333	385	1/3	3074
4666 0.39/6.2	3395 0.38/5.8	-	-	-	-	-	-	-	-	-	-	TXBHP-30501	405	1/2	3234
4942 0.43/6.7	3992 0.44/6.2	-	-	-	-	-	-	-	-	-	-	TXBHP-30502	420	1/2	3354
5298 0.49/7.3	4548 0.51/6.8	-	-	-	-	-	-	-	-	-	-	TXBHP-30503	440	1/2	3513
5643 0.56/8.0	4997 0.58/7.4	3645 0.54/7.1	-	-	-	-	-	-	-	-	-	TXBHP-30751	460	3/4	3673
5980 0.63/8.7	5407 0.65/8.2	4430 0.65/78	-	-	-	-	-	-	-	-	-	TXBHP-30752	480	3/4	3833
6311 0.70/9.5	5789 0.73/8.9	5053 0.74/8.4	3581 0.68/8.3	-	-	-	-	-	-	-	-	TXBHP-30753	500	3/4	3992
6638 0.79/10.3	6154 0.82/9.6	5527 0.84/9.1	4265 0.79/9.0	-	-	-	-	-	-	-	-	TXBHP-30101	520	1	4152
6880 0.85/10.9	6420 0.89/10.3	5851 0.91/9.7	4890 0.89/9.4	3348 0.77/9.5	-	-	-	-	-	-	-	TXBHP-30102	535	1	4272
7201 0.94/11.8	6767 0.98/11.1	6258 1.01/10.6	5545 1.02/10.1	4180 0.94/10.1	-	-	-	-	-	-	-	TXBHP-30103	555	1	4432
7597 1.07/12.7	7192 1.11/12.2	6734 1.14/11.5	6148 1.16/11.0	5113 1.13/10.9	-	-	-	-	-	-	-	TXBHP-30151	580	1-1/2	4631
7989 1.20/13.6	7608 1.25/13.0	7817 1.29/12.5	6684 1.31/12.0	5996 1.32/11.6	-	-	-	-	-	-	-	TXBHP-30152	605	1-1/2	4831
8379 1.35/14.6	8018 1.40/14.0	7627 1.44/13.5	7181 1.47/13.0	6614 1.49/12.5	4439 1.35/12.4	-	-	-	-	-	-	TXBHP-30153	630	1-1/2	5030
8765 1.51/15.6	8423 1.56/15.0	8055 1.61/14.4	7649 1.64/14.0	7161 1.67/13.5	5303 1.58/13.2	-	-	-	-	-	-	TXBHP-30201	655	2	5230
9073 1.64/16.3	8743 1.70/15.8	8393 1.75/15.3	8011 1.79/14.8	7570 1.82/14.3	6119 1.79/13.9	-	-	-	-	-	-	TXBHP-30202	675	2	5390
9456 1.82/17.3	9141 1.88/16.8	8808 1.94/16.3	8451 1.98/15.8	8055 2.02/15.4	6960 2.04/14.7	-	-	-	-	-	-	TXBHP-30203	700	2	5589
9988 2.09/18.7	9692 2.16/18.2	9381 2.22/17.8	9052 2.27/17.3	8696 2.31/16.9	7808 2.36/16.1	6018 2.24/16.3	-	-	-	-	-	TXBHP-30301	735	3	5869
10443 2.35/19.9	10159 2.42/19.4	9865 2.48/19.0	9556 2.54/18.6	9226 2.59/18.2	8449 2.66/17.4	7224 2.63/17.3	-	-	-	-	-	TXBHP-30302	765	3	6108
10970 2.67/21	10701 2.75/21	10423 2.82/21	10134 2.88/20	9828 2.93/20	9143 3.02/19.0	8224 3.05/19.0	6421 2.87/19.0	-	-	-	-	TXBHP-30303	800	3	6388
11720 3.18/23	11469 3.26/23	11211 3.34/23	10944 3.41/22	10667 3.47/22	10065 3.58/21	9337 3.65/21	8308 3.64/21	6462 3.39/21	-	-	-	TXBHP-305001	850	5	6787
12392 3.69/26	12155 3.78/25	11912 3.86/25	11663 3.94/24	11405 4.01/24	10855 4.13/23	10233 4.22/23	9445 4.27/22	8174 4.18/23	-	-	-	TXBHP-305002	895	5	7146
13135 4.32/28	12912 4.42/28	12684 4.51/27	12451 4.59/27	12211 4.67/26	11708 4.81/26	11156 4.92/25	10513 4.96/25	9692 5.03/25	8529 4.85/25	6658 4.54/25	-	TXBHP-305003	945	5	7546
14172 5.32/32	13964 5.43/31	13754 5.53/30	13541 5.62/30	13322 5.71/30	12868 5.87/29	12385 6.01/28	11856 6.12/28	11239 6.20/28	10477 6.23/28	9274 6.10/28	7691 5.77/29	TXBHP-307501	1015	7-1/2	8104
15130 6.38/36	14936 6.49/35	14740 6.60/35	14541 6.71/34	14338 6.81/34	13921 6.99/33	13483 7.15/32	13015 7.28/31	12504 7.39/31	11910 7.47/31	11193 7.50/31	10150 7.40/31	TXBHP-307502	1080	7-1/2	8623

Power Ratings (BHP) does not include drive losses.

Performance certified is for installation type A - free inlet, free outlet.

Performance ratings do not include the effects of birdscreen in the airstream.

The sound ratings shown are loudness values in fan sones @ 5' (1.5m) in a hemispherical free field calculated per AMCA Standard 301. Values shown are for free inlet fan sone levels.



Soler & Palau USA, Div. of Soler & Palau Ventilation Group, certifies that the Models TXB shown herein are licensed to bear the AMCA Seal. The ratings shown are based on test and procedures performed in accordance with AMCA Publication 211 and AMCA Publication 311 and comply with the requirement of the AMCA Certified Ratings Program.



**UL STANDARD 705 for Electrical
UL STANDARD 762 for
Grease Removal**

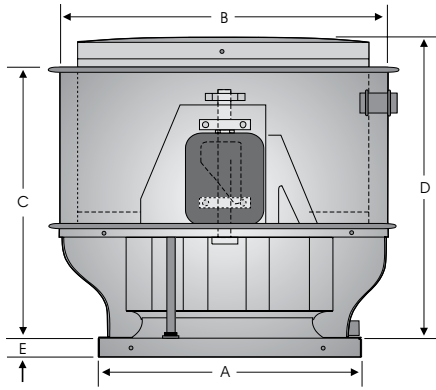

Dimensions (in.)				
A	B	C	D	E
42-1/2	66	44	48	2-1/2

Dimensional Data				Metal Thickness			Avg. Ship Wt. (lbs.)
Damper		Roof Opening	Curb OD	Curb Cap	Wind Band	Motor Cover	
ID	OD						
36	36	37-3/4	40-3/4	.090	.050	.050	365

SIZE 36

TXB 36

CFM / BHP @ Static Pressure / Sones													Catalog Number	RPM	HP	Tip Speed
0	1/8	1/4	3/8	1/2	5/8	3/4	1	1-1/4	1-1/2	1-3/4	2					
7797 0.30/5.3	6629 0.33/4.9	4391 0.31/4.3	-	-	-	-	-	-	-	-	-	-	TXB-36501	270	1/2	2523
8953 0.45/6.8	8009 0.49/6.4	6496 0.50/6.0	3165 0.35/4.4	-	-	-	-	-	-	-	-	-	TXB-36502	310	1/2	2896
9386 0.52/7.3	8503 0.56/6.9	7139 0.57/6.6	5105 0.53/5.6	-	-	-	-	-	-	-	-	-	TXB-36751	325	3/4	3036
9819 0.60/7.9	8988 0.64/7.5	7771 0.66/7.2	5791 0.62/6.8	-	-	-	-	-	-	-	-	-	TXB-36852	340	3/4	3177
10252 0.68/8.5	9468 0.72/8.1	8369 0.75/7.7	6717 0.73/7.4	-	-	-	-	-	-	-	-	-	TXB-36753	355	3/4	3317
10685 0.77/9.1	9942 0.81/8.7	8940 0.85/8.3	7521 0.84/8.0	5459 0.76/6.8	-	-	-	-	-	-	-	-	TXB-36101	370	1	3457
10974 0.83/9.5	10255 0.88/9.1	9308 0.92/8.7	7971 0.91/8.4	6124 0.85/7.7	-	-	-	-	-	-	-	-	TXB-36102	380	1	3550
11407 0.93/10.2	10722 0.98/9.8	9844 1.02/9.4	8611 1.03/9.0	6793 0.97/8.7	-	-	-	-	-	-	-	-	TXB-36103	395	1	3690
11985 1.08/11.0	11339 1.14/10.6	10537 1.18/10.3	9459 1.20/9.9	8086 1.17/9.6	6251 1.08/8.4	-	-	-	-	-	-	-	TXB-36151	415	1-1/2	3877
12418 1.21/11.8	11799 1.26/11.3	11045 1.31/10.9	10063 1.33/10.6	7081 1.32/10.3	7081 1.24/9.7	-	-	-	-	-	-	-	TXB-36152	430	1-1/2	4017
12996 1.34/12.7	12410 1.44/12.4	11710 1.49/12.0	10832 1.53/11.5	9685 1.52/11.2	8075 1.46/10.9	6094 1.32/9.5	-	-	-	-	-	-	TXB-36153	450	1-1/2	4204
13285 1.48/13.2	12713 1.53/12.8	12037 1.59/12.5	11203 1.63/12.1	10113 1.63/11.7	8792 1.59/11.4	7239 1.50/10.3	-	-	-	-	-	-	TXB-36201	460	2	4298
13573 1.50/13.7	13016 1.63/13.3	12362 1.69/12.9	11566 1.73/12.7	10540 1.74/12.2	9344 1.71/11.9	7711 1.62/11.4	-	-	-	-	-	-	TXB-36202	470	2	4391
13862 1.68/14.2	13318 1.74/13.8	12685 1.79/13.4	11923 1.84/13.0	10955 1.86/12.8	9817 1.83/12.4	8152 1.74/12.2	-	-	-	-	-	-	TXB-36203	480	2	4484
14295 1.84/15.0	13770 1.90/14.6	13165 1.96/14.2	12449 2.01/13.8	11560 2.04/13.5	10483 2.02/13.3	8988 1.95/13.0	-	-	-	-	-	-	TXB-36204	495	2	4625
14873 2.07/15.9	14371 2.14/15.6	13799 2.20/15.2	13135 2.25/14.8	12334 2.29/14.5	11337 2.29/14.2	10243 2.25/14.0	-	-	-	-	-	-	TXB-36301	515	3	4811
15306 2.26/16.6	14819 2.32/16.3	14271 2.39/16.0	13640 2.45/15.6	12894 2.49/15.3	11973 2.50/15.1	10944 2.47/14.8	8299 2.29/13.4	-	-	-	-	-	TXB-36302	530	3	4952
15884 2.52/17.7	15416 2.59/17.3	14895 2.66/16.9	14304 2.72/16.6	13617 2.77/16.4	12788 2.79/16.2	11814 2.78/16.0	9226 2.61/15.5	-	-	-	-	-	TXB-36303	550	3	5138
16317 2.74/18.5	15863 2.81/18.1	15361 2.87/17.7	14795 2.94/17.4	14146 2.99/17.2	13377 3.03/17	12455 3.02/16.8	9936 2.87/16.3	-	-	-	-	-	TXB-36304	565	3	5279
16894 3.04/19.5	16458 3.11/19.1	15978 3.18/18.8	15443 3.25/18.5	14837 3.31/18.3	14135 3.35/18.1	13299 3.36/17.8	11336 3.28/17.4	8629 3.01/15.6	-	-	-	-	TXB-365001	585	5	5465
17472 3.36/21	17052 3.43/20	16592 3.51/20	16085 3.58/20	15516 3.64/19.0	14868 3.69/19.0	14109 3.72/19.0	12318 3.67/19.0	9875 3.45/18.0	-	-	-	-	TXB-365002	605	5	5652
18194 3.79/22	17792 3.87/22	17356 3.95/21	16877 4.02/21	16349 4.09/21	15756 4.15/21	15078 4.19/20	13425 4.17/20	11005 3.97/19.0	-	-	-	-	TXB-365003	630	5	5886
18772 4.17/23	18382 4.25/23	17963 4.33/22	17507 4.40/22	17006 4.48/22	16450 4.54/22	15824 4.59/21	14278 4.60/21	12396 4.48/21	10209 4.23/19	-	-	-	TXB-365004	650	5	6073
19349 4.56/24	18972 4.65/24	18568 4.73/24	18131 4.81/23	17654 4.88/23	17131 4.95/23	16548 5.01/23	15128 5.05/22	13471 4.97/22	11141 4.71/21	-	-	-	TXB-365005	670	5	6260
20793 5.66/27	20443 5.75/27	20074 5.84/26	19677 5.93/26	19252 6.01/26	18793 6.09/26	18292 6.16/26	17125 6.26/25	15671 6.24/25	14067 6.13/24	11871 5.83/23	-	-	TXB-367501	720	7-1/2	6727
22093 6.79/30	21765 6.89/30	21420 6.98/29	21055 7.07/29	20666 7.17/29	20252 7.25/29	19805 7.34/28	18797 7.47/28	17569 7.52/27	16160 7.46/27	14373 7.27/26	12478 6.97/26	-	TXB-367502	765	7-1/2	7147

Power Ratings (BHP) does not include drive losses.
 Performance certified is for installation type A - free inlet, free outlet.
 Performance ratings do not include the effects of birdscreen in the airstream.
 The sound ratings shown are loudness values in fan sones @ 5' (1.5m) in a hemispherical free field calculated per AMCA Standard 301. Values shown are for free inlet fan sone levels.



Soler & Palau USA, Div. of Soler & Palau Ventilation Group, certifies that the Models TXB shown herein are licensed to bear the AMCA Seal. The ratings shown are based on test and procedures performed in accordance with AMCA Publication 211 and AMCA Publication 311 and comply with the requirement of the AMCA Certified Ratings Program.



UL STANDARD 705 for Electrical
UL STANDARD 762 for Grease Removal

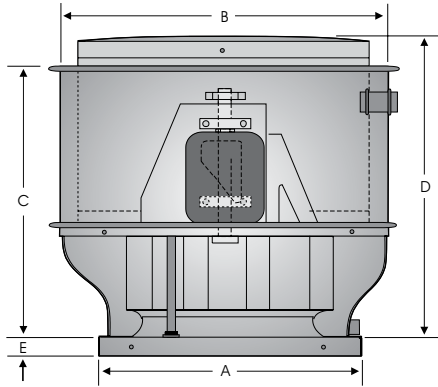

Dimensions (in.)				
A	B	C	D	E
42-1/2	66	44	48	2-1/2

Dimensional Data				Metal Thickness			Avg. Ship Wt. (lbs.)
Damper		Roof Opening	Curb OD	Curb Cap	Wind Band	Motor Cover	
ID	OD						
36	36	37-3/4	40-3/4	.090	.050	.050	365

SIZE 36 - HIGH PRESSURE

TXBHP 36

CFM / BHP @ Static Pressure / Sones													Catalog Number	RPM	HP	Tip Speed
1/2	5/8	3/4	1	1-1/4	1-1/2	1-3/4	2	2-1/4	2-1/2	2-3/4	3					
5889 0.83/7.6	-	-	-	-	-	-	-	-	-	-	-	-	TXBHP-36101	405	1	3784
6412 0.90/7.9	-	-	-	-	-	-	-	-	-	-	-	-	TXBHP-36102	415	1	3877
7078 1.02/8.4	-	-	-	-	-	-	-	-	-	-	-	-	TXBHP-36103	430	1	4017
7862 1.17/9.2	6415 1.13/9.1	-	-	-	-	-	-	-	-	-	-	-	TXBHP-36151	450	1-1/2	4204
8575 1.33/9.9	7448 1.32/9.7	5189 1.15/10.2	-	-	-	-	-	-	-	-	-	-	TXBHP-36152	470	1-1/2	4391
9240 1.50/10.7	8286 1.51/10.5	6822 1.44/10.7	-	-	-	-	-	-	-	-	-	-	TXBHP-36153	490	1-1/2	4578
9715 1.63/11.3	8860 1.66/11.1	7692 1.62/11.2	-	-	-	-	-	-	-	-	-	-	TXBHP-36201	505	2	4718
10021 1.72/11.8	9222 1.75/11.5	8166 1.74/11.5	-	-	-	-	-	-	-	-	-	-	TXBHP-36202	515	2	4811
10467 1.86/12.5	9741 1.91/12.1	8807 1.91/12.0	-	-	-	-	-	-	-	-	-	-	TXBHP-36203	530	2	4952
10760 1.96/13.0	10075 2.01/12.6	9204 2.02/12.4	5776 1.73/13.4	-	-	-	-	-	-	-	-	-	TXBHP-36204	540	2	5045
11335 2.16/13.7	10718 2.23/13.5	9953 2.26/13.3	7428 2.11/13.9	-	-	-	-	-	-	-	-	-	TXBHP-36301	560	3	5232
11899 2.37/14.6	11330 2.45/14.3	10651 2.45/14.0	8725 2.45/14.5	-	-	-	-	-	-	-	-	-	TXBHP-36302	580	3	5419
12456 2.60/15.4	11921 2.69/15.1	11312 2.75/14.9	9665 2.76/15.0	-	-	-	-	-	-	-	-	-	TXBHP-36303	600	3	5606
13005 2.85/16.3	12499 2.94/16.0	11946 3.01/15.7	10489 3.06/15.6	7767 2.79/16.5	-	-	-	-	-	-	-	-	TXBHP-36304	620	3	5792
13684 3.18/17.4	13207 3.27/17.2	12698 3.36/16.9	11484 3.45/16.4	9572 3.36/17.2	-	-	-	-	-	-	-	-	TXBHP-365001	645	5	6026
14222 3.46/18.3	13765 3.55/18.1	13283 3.65/17.8	12188 3.77/17.3	10548 3.74/17.7	-	-	-	-	-	-	-	-	TXBHP-365002	665	5	6213
14888 3.83/19.5	14454 3.93/19.2	14000 4.03/19.0	12971 4.18/18.5	11602 4.22/19.2	9428 3.99/20	-	-	-	-	-	-	-	TXBHP-365003	690	5	6446
15417 4.15/20	14998 4.25/20	14564 4.36/19.9	13608 4.53/19.4	12374 4.6/19.1	10667 4.5/19.8	-	-	-	-	-	-	-	TXBHP-365004	710	5	6633
16074 4.57/22	15673 4.68/21	15259 4.79/21	14372 4.98/21	13277 5.10/20	11884 5.07/21	9319 4.67/21	-	-	-	-	-	-	TXBHP-365005	735	5	6867
17506 5.60/24	17136 5.72/24	16761 5.84/24	15974 6.06/23	15095 6.25/23	14005 6.34/22	12622 6.29/23	10338 5.88/24	-	-	-	-	-	TXBHP-367501	790	7-1/2	7381
18794 6.66/26	18449 6.79/26	18099 6.92/26	17379 7.16/26	16608 7.39/25	15721 7.56/25	14638 7.62/25	13290 7.54/25	11142 7.12/26	-	-	-	-	TXBHP-367502	840	7-1/2	7848
19817 7.61/28	19488 7.74/28	19157 7.87/28	18479 8.14/28	17767 8.39/27	16993 8.61/27	16067 8.73/26	14959 8.75/27	13585 8.63/27	11274 8.06/28	-	-	-	TXBHP-361001	880	10	8222
20834 8.64/31	20520 8.78/30	20205 8.92/30	19563 9.20/30	18897 9.47/30	18188 9.71/29	17392 9.90/29	16453 9.99/29	15337 9.99/29	11556 9.13/29	8370 7.79/30	-	-	TXBHP-361002	920	10	8595

Power Ratings (BHP) does not include drive losses.
 Performance certified is for installation type A - free inlet, free outlet.
 Performance ratings do not include the effects of birdscreen in the airstream.
 The sound ratings shown are loudness values in fan sones @ 5' (1.5m) in a hemispherical free field calculated per AMCA Standard 301. Values shown are for free inlet fan sone levels.



Soler & Palau USA, Div. of Soler & Palau Ventilation Group, certifies that the Models TXB shown herein are licensed to bear the AMCA Seal. The ratings shown are based on test and procedures performed in accordance with AMCA Publication 211 and AMCA Publication 311 and comply with the requirement of the AMCA Certified Ratings Program.



UL STANDARD 705 for Electrical
UL STANDARD 762 for Grease Removal

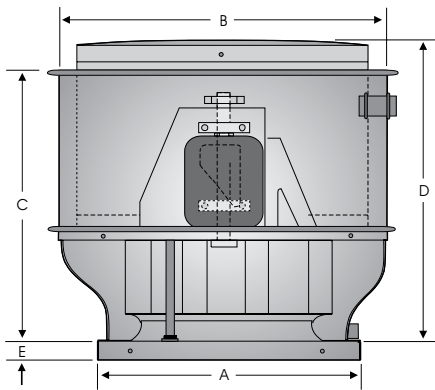

Dimensions (in.)				
A	B	C	D	E
55	72-1/2	48	52	2-1/2

Dimensional Data				Metal Thickness			Avg. Ship Wt. (lbs.)
Damper		Roof Opening	Curb OD	Curb Cap	Wind Band	Motor Cover	
ID	OD						
48	48	50-1/4	53-1/4	.100	.050	.050	385

SIZE 42

TXB 42

CFM / BHP @ Static Pressure / Sones													RPM	HP	Tip Speed
0	1/8	1/4	3/8	1/2	5/8	3/4	1	1-1/4	1-1/2	1-3/4	2	Catalog Number			
10306 0.28/6.8	7988 0.33/6.8	-	-	-	-	-	-	-	-	-	-	TXB-42501	200	1/2	2199
11852 0.43/8.2	10011 0.49/8.2	6471 0.45/8.2	-	-	-	-	-	-	-	-	-	TXB-42502	230	1/2	2829
12625 0.52/9.0	10926 0.59/8.9	7540 0.57/8.8	-	-	-	-	-	-	-	-	-	TXB-42751	245	3/4	2694
13656 0.66/10.0	12109 0.74/9.9	9589 0.76/9.8	-	-	-	-	-	-	-	-	-	TXB-42752	265	3/4	2914
14429 0.78/10.8	12977 0.86/10.6	11065 0.91/10.5	7791 0.81/10.4	-	-	-	-	-	-	-	-	TXB-42101	280	1	3079
14944 0.86/11.4	13549 0.95/11.2	11868 1.01/11.0	8543 0.93/10.8	-	-	-	-	-	-	-	-	TXB-42102	290	1	3189
15459 0.96/11.9	14116 1.05/11.8	12546 1.11/11.6	9230 1.04/11.4	-	-	-	-	-	-	-	-	TXB-42151	300	1-1/2	3299
16232 1.11/12.6	14959 1.20/12.4	13514 1.28/12.3	10696 1.26/12.2	8017 1.12/12.0	-	-	-	-	-	-	-	TXB-42152	315	1-1/2	3464
17005 1.27/13.4	15795 1.37/13.3	14449 1.46/13.1	12322 1.49/13.0	9513 1.35/12.8	-	-	-	-	-	-	-	TXB-42153	330	1-1/2	3628
17521 1.39/14.0	16349 1.50/13.8	15060 1.58/13.7	13278 1.63/13.5	10223 1.50/13.3	6983 1.22/13.0	-	-	-	-	-	-	TXB-42201	340	2	3738
18294 1.59/14.9	17174 1.69/14.7	15960 1.79/14.6	14521 1.86/14.4	11441 1.76/14.1	9452 1.92/13.8	-	-	-	-	-	-	TXB-42202	355	2	3903
18809 1.72/15.4	17772 1.83/15.3	16553 1.93/15.1	15207 2.01/15.0	12488 1.96/14.8	10337 1.81/14.3	6123 1.39/14.0	-	-	-	-	-	TXB-42203	365	2	4013
19582 1.95/16.3	18540 2.06/16.1	17430 2.17/15.9	16182 2.25/15.8	14122 2.27/15.6	11420 2.10/15.2	8695 1.85/14.8	-	-	-	-	-	TXB-42301	380	3	4178
20355 2.18/17.2	19354 2.31/17.0	18296 2.42/16.8	17129 2.51/16.6	15546 2.56/16.5	12609 2.42/16.2	10936 2.27/15.7	-	-	-	-	-	TXB-42302	395	3	4343
21128 2.44/18.0	20165 2.57/17.8	19154 2.68/17.7	18055 2.79/17.5	16774 2.86/17.3	14170 2.79/17.1	12073 2.61/16.6	-	-	-	-	-	TXB-42303	410	3	4508
21643 2.63/18.6	20705 2.75/18.4	19722 2.87/18.2	18661 2.98/18.1	17462 3.07/17.9	15269 3.04/17.7	12766 2.85/17.3	6656 2.09/16.4	-	-	-	-	TXB-425001	420	5	4618
22159 2.82/19.3	21243 2.95/19.1	20286 3.07/18.9	19262 3.18/18.7	18119 3.28/18.5	16303 3.29/18.3	13562 3.11/18.0	8822 2.47/17.0	-	-	-	-	TXB-425002	430	5	4728
22931 3.12/20	22048 3.26/20	21129 3.39/19.8	20153 3.51/19.6	19082 3.61/19.4	17681 3.67/19.3	15074 3.54/19.0	11238 3.14/18.0	-	-	-	-	TXB-425003	445	5	4893
23447 3.34/21	22538 3.48/21	21687 3.61/20	20740 3.73/20	19710 3.84/20	18484 3.91/19.9	16173 3.85/19.7	12535 3.47/18.6	-	-	-	-	TXB-425004	455	5	5003
24220 3.68/22	23384 3.83/22	22521 3.96/21	21614 4.09/21	20638 4.20/21	19551 4.29/21	17756 4.3/21	13694 3.92/19.7	-	-	-	-	TXB-425005	470	5	5168
24735 3.92/22	23917 4.07/22	23074 4.21/22	22181 4.34/22	21247 4.46/22	20208 4.56/21	18703 4.60/21	14400 4.23/20	9783 3.41/19.0	-	-	-	TXB-425006	480	5	5278
25508 4.30/23	24176 4.45/23	23901 4.60/23	23052 4.74/23	22152 4.86/23	21173 4.97/22	19975 5.04/22	15519 4.73/22	12017 4.24/20	-	-	-	TXB-425007	495	5	5443
26539 4.84/25	25778 5.00/25	24997 5.15/24	24188 5.30/24	23339 5.43/24	22429 5.55/24	21427 5.65/24	17525 5.50/23	14525 5.08/22	-	-	-	TXB-427501	515	7-1/2	5663
27312 5.28/26	26573 5.44/25	25817 5.60/25	25035 5.75/25	24218 5.89/25	23351 6.02/25	22410 6.13/25	19179 6.11/24	15634 5.65/23	11323 4.74/22	-	-	TXB-427502	530	7-1/2	5828
28342 5.90/27	27631 6.07/27	26904 6.23/26	26152 6.39/26	25378 6.54/26	24561 6.68/26	23684 6.80/26	21215 6.91/25	17031 6.45/24	14648 6.04/24	-	-	TXB-427503	530	7-1/2	6047
29115 6.39/28	28423 6.57/28	27717 6.74/27	26992 6.90/27	26241 7.06/27	25455 7.20/27	24621 7.33/27	22538 7.50/26	18467 7.15/26	15978 6.72/25	11004 5.45/24	-	TXB-427504	565	7-1/2	6212

Power Ratings (BHP) does not include drive losses.
 Performance certified is for installation type A - free inlet, free outlet.
 Performance ratings do not include the effects of birdscreen in the airstream.
 The sound ratings shown are loudness values in fan sones @ 5' (1.5m) in a hemispherical free field calculated per AMCA Standard 301. Values shown are for free inlet fan some levels.



Soler & Palau USA, Div. of Soler & Palau Ventilation Group, certifies that the Models TXB shown herein are licensed to bear the AMCA Seal. The ratings shown are based on test and procedures performed in accordance with AMCA Publication 211 and AMCA Publication 311 and comply with the requirement of the AMCA Certified Ratings Program.



UL STANDARD 705 for Electrical
UL STANDARD 762 for Grease Removal

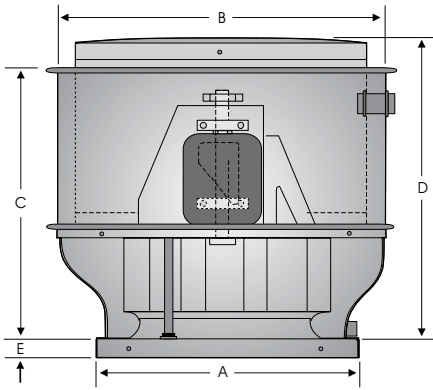

Dimensions (in.)				
A	B	C	D	E
55	78-3/4	52	55	2-1/2

Damper		Metal Thickness					Avg. Ship Wt. (lbs.)
ID	OD	Roof Opening	Curb OD	Curb Cap	Wind Band	Motor Cover	
48	48	50-1/4	53-1/4	.100	.050	.050	490

SIZE 48

TXB 48

CFM / BHP @ Static Pressure / Sones													RPM	HP	Tip Speed
0	1/8	1/4	3/8	1/2	5/8	3/4	1	1-1/4	1-1/2	1-3/4	2	Catalog Number			
11713	8527	-	-	-	-	-	-	-	-	-	-	TXB-48501	170	1/2	2114
0.33/3.5	0.37/3.1	-	-	-	-	-	-	-	-	-	-	-	-	-	-
12402	9664	-	-	-	-	-	-	-	-	-	-	TXB-48502	180	1/2	2238
0.39/3.9	0.44/3.6	-	-	-	-	-	-	-	-	-	-	-	-	-	-
13091	10066	-	-	-	-	-	-	-	-	-	-	TXB-48503	190	1/2	2363
0.46/4.3	0.52/4.0	-	-	-	-	-	-	-	-	-	-	-	-	-	-
13091	10666	-	-	-	-	-	-	-	-	-	-	TXB-48751	205	3/4	2549
0.46/4.3	0.52/4.7	-	-	-	-	-	-	-	-	-	-	-	-	-	-
14813	12737	8924	-	-	-	-	-	-	-	-	-	TXB-48752	215	3/4	2674
0.67/5.4	0.75/5.2	0.70/5.2	-	-	-	-	-	-	-	-	-	-	-	-	-
15847	13896	10899	-	-	-	-	-	-	-	-	-	TXB-48101	230	1	2860
0.82/6.1	0.91/5.9	0.90/5.6	-	-	-	-	-	-	-	-	-	-	-	-	-
16536	14656	12014	-	-	-	-	-	-	-	-	-	TXB-48102	240	1	2984
0.93/6.0	1.02/6.3	1.04/6.1	-	-	-	-	-	-	-	-	-	-	-	-	-
17225	15408	13163	-	-	-	-	-	-	-	-	-	TXB-48151	250	1-1/2	3109
1.05/7.0	1.15/6.7	1.19/6.5	-	-	-	-	-	-	-	-	-	-	-	-	-
17914	16154	14236	10299	-	-	-	-	-	-	-	-	TXB-48152	260	1-1/2	3233
1.18/7.4	1.29/7.2	1.34/7.0	1.22/7.0	-	-	-	-	-	-	-	-	-	-	-	-
18603	16895	15206	11919	-	-	-	-	-	-	-	-	TXB-48153	270	1-1/2	3358
1.32/7.9	1.44/7.6	1.50/7.4	1.41/7.3	-	-	-	-	-	-	-	-	-	-	-	-
19636	17999	16495	13726	9349	-	-	-	-	-	-	-	TXB-48201	285	2	3544
1.56/8.5	1.68/8.3	1.75/8.1	1.72/7.9	1.48/8.3	-	-	-	-	-	-	-	-	-	-	-
20670	19097	17694	15399	11849	-	-	-	-	-	-	-	TXB-48202	300	2	3731
1.87/9.2	1.95/9.0	2.03/8.8	2.04/8.5	1.87/8.6	-	-	-	-	-	-	-	-	-	-	-
21359	19825	18476	16546	13528	8885	-	-	-	-	-	-	TXB-48301	310	3	3855
2.00/9.8	2.14/9.5	2.23/9.3	2.26/9.1	2.12/9.0	1.77/9.9	-	-	-	-	-	-	-	-	-	-
22048	20551	19249	17592	14793	10661	-	-	-	-	-	-	TXB-48302	320	3	3979
2.20/10.3	2.35/10.1	2.44/9.8	2.49/9.6	2.39/9.5	2.11/10.0	-	-	-	-	-	-	-	-	-	-
22737	21275	20013	18560	15952	12193	-	-	-	-	-	-	TXB-48303	330	3	4104
2.42/10.8	2.57/10.6	2.67/10.4	2.73/10.2	2.67/10.0	2.44/10.3	-	-	-	-	-	-	-	-	-	-
23426	21997	20771	19458	17054	14121	9830	-	-	-	-	-	TXB-48304	340	3	4228
2.64/11.5	2.80/11.2	2.91/11.0	2.98/10.8	2.95/10.6	2.76/10.7	2.34/10.7	-	-	-	-	-	-	-	-	-
24459	23071	21898	20682	18779	16204	12357	-	-	-	-	-	TXB-485001	355	5	4415
3.01/12.4	3.18/12.1	3.29/11.8	3.38/11.6	3.40/11.5	3.25/11.4	2.95/12.0	-	-	-	-	-	-	-	-	-
25837	24513	23387	22266	20855	18507	15915	-	-	-	-	-	TXB-485002	375	5	4663
3.55/13.8	3.73/13.5	3.86/13.3	3.95/13.1	4.01/13.0	3.94/12.9	3.72/13.0	-	-	-	-	-	-	-	-	-
26871	25587	24495	23428	22250	20201	17886	10701	-	-	-	-	TXB-485003	390	5	4850
3.99/14.8	4.18/14.6	4.32/14.5	4.42/14.3	4.50/14.2	4.49/14.1	4.31/14.1	3.44/15.0	-	-	-	-	-	-	-	-
27904	26658	25598	24574	23485	21877	19631	13520	-	-	-	-	TXB-485004	405	5	5036
4.47/15.8	4.67/15.7	4.82/15.5	4.93/15.4	5.02/15.4	5.05/15.4	4.94/15.5	4.28/15.6	-	-	-	-	-	-	-	-
29282	28083	27061	26086	25081	23863	21866	16901	8340	-	-	-	TXB-487501	425	7-1/2	5285
5.16/17.3	5.38/17.2	5.54/17.1	5.66/17.1	5.77/17.0	5.84/17.1	5.84/17.0	5.33/17.0	3.81/17.8	-	-	-	-	-	-	-
30316	29150	28153	27209	26253	25207	23573	19343	12941	-	-	-	TXB-487502	440	7-1/2	5471
5.73/18.5	5.95/18.4	6.12/18.3	6.26/18.3	6.37/18.1	6.46/18	6.48/17.8	6.09/17.7	5.12/18.4	-	-	-	-	-	-	-
31694	30569	29604	29697	27792	26837	25111	21797	16210	-	-	-	TXB-487503	460	7-1/2	5720
6.55/19.9	6.78/19.8	6.96/19.6	7.12/19.4	7.24/19.3	7.3/19.1	7.40/19.0	7.17/18.7	6.47/19.2	-	-	-	-	-	-	-
33072	31984	31049	30174	29311	28422	27448	24028	19817	13705	-	-	TXB-481001	480	10	5969
7.44/21	7.69/21	7.88/21	8.05/21	8.18/21	8.30/20	8.39/20	8.31/19.9	7.75/20	6.55/20.9	-	-	-	-	-	-
34105	33045	32130	31276	30441	29589	28681	25750	22031	16402	-	-	TXB-481002	495	10	6155
8.16/22	8.42/22	8.62/22	8.79/22	8.94/21	9.07/21	9.17/21	9.19/21	8.72/21	7.79/21	-	-	-	-	-	-
35139	34105	33209	32375	31563	30747	29887	27429	23870	18697	12370	-	TXB-481003	510	10	6342
8.92/23	9.19/23	9.40/23	9.59/23	9.74/22	9.88/22	9.99/22	10.09/22	9.73/21	8.99/22	7.27/23	-	-	-	-	-

Power Ratings (BHP) does not include drive losses.
 Performance certified is for installation type A - free inlet, free outlet.
 Performance ratings do not include the effects of birdscreen in the airstream.
 The sound ratings shown are loudness values in fan sones @ 5' (1.5m) in a hemispherical free field calculated per AMCA Standard 301. Values shown are for free inlet fan sone levels.



Soler & Palau USA, Div. of Soler & Palau Ventilation Group, certifies that the Models TXB shown herein are licensed to bear the AMCA Seal. The ratings shown are based on test and procedures performed in accordance with AMCA Publication 211 and AMCA Publication 311 and comply with the requirement of the AMCA Certified Ratings Program.



UL STANDARD 705 for Electrical
 UL STANDARD 762 for Grease Removal

Additional Products

Soler & Palau USA manufactures a complete line of gravity ventilators and fans for all your ventilation requirements.



MODEL DB

Backward Inclined
Belt Drive
Centrifugal Roof Exhaust



MODEL RED

Backward Inclined
Direct Drive
Centrifugal Roof Exhaust



MODEL SQB/SQD

Backward Inclined
Belt Drive/Direct Drive
Square Inline



MODEL UBB/UBX/UBS

Propeller
Belt and Direct Drive
Upblast Roof Exhaust



MODEL L

Propeller
Belt Drive
Sidewall Exhaust or Supply



MODEL BGH

Gravity Hood
Intake or Relief



MODEL KSF

Forward Curved Blower
Belt Drive
Filtered Roof Supply



MODEL TXB/TXD

Backward Inclined
Belt Drive/Direct Drive
Centrifugal Upblast

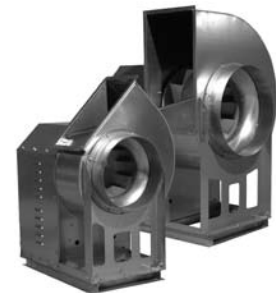

MODEL BVS

Backward Inclined
Belt Drive
Centrifugal Utility Set

DUE TO CONTINUING RESEARCH SOLER & PALAU USA RESERVES THE RIGHT TO CHANGE SPECIFICATIONS WITHOUT NOTICE

Distributed By:



Soler & Palau USA
6393 Powers Avenue
Jacksonville, FL 32217
800.961.7370
800.961.7379
www.solerpalau-usa.com