

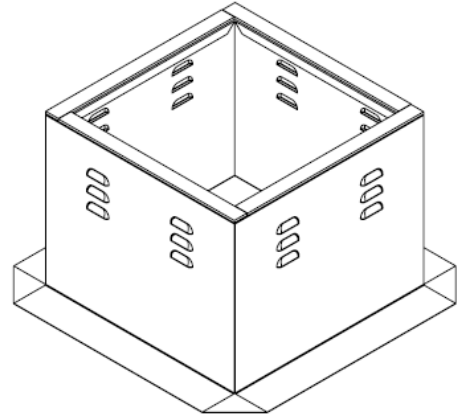

# TYPE SFR SPECIAL RESTAURANT CURBS SELF-FLASHING TYPE

## STANDARD FEATURES:

- Constructed of 18 ga. galv. steel with continuous welded seams and integral base plate for water tightness and extra strength.
- Welded corners for better lay of materials at corners.
- Insulation not furnished on SFR type curbs.
- Top ledge covered with 1/4" polystyrene gasket for weather seal and to reduce metal conducted noise.
- Minimum curb height is 18" to comply with NFPA Bulletin 96.



## OPTIONS:

- Constructed of .063" aluminum.
- Any height.
- Protective or decorative coatings.
- Heavy-gauge construction.

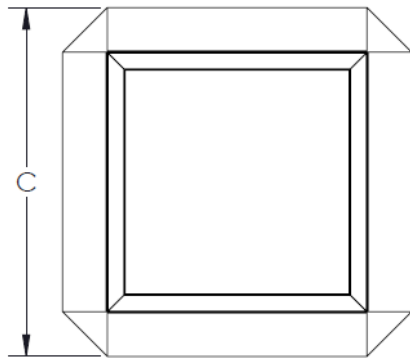

TOP VIEW

PART NUMBER	STXB RHUL MODEL SIZE	STXD/e RHUL MODEL SIZE	A	B	C
721816V	08-10	-	16-1/2	18	24-1/4
722416V	-	10	16-1/2	24	24-1/4
721818V	12-14	-	18-1/2	18	26-1/4
722418V	-	12-14	18-1/2	24	26-1/4
721822V	15-16	15-16	22-1/2	18	30-1/4
721828V	18-20-22	-	28-1/2	18	36-1/4
721834V	24-27	-	34-1/2	18	42-1/4
721840V	30-33-36	-	40-1/2	18	48-1/4
721852V	42-48	-	52-3/4	18	60-1/2

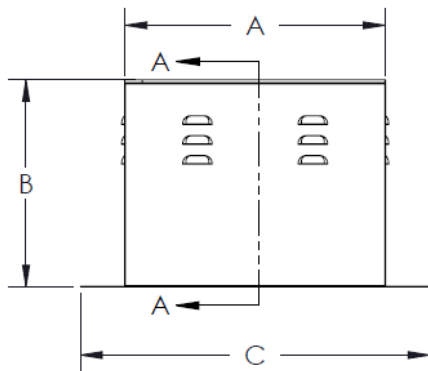

SIDE VIEW

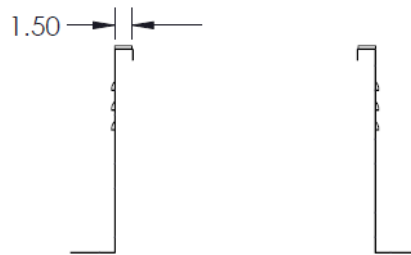

SECTION A-A