

KSFV-FB

Belt Drive Kitchen Supply Fan Filtered Units

FILTERED UNITS

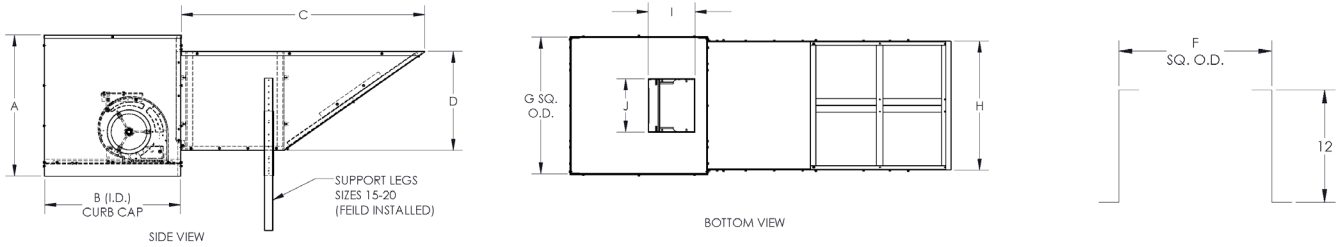

MODEL SIZE	A	B SQ.	C	D	F SQ.	G SQ.	H	I	J	DAMPER O.D.
KSFV09FB	30	23-7/8	45-5/8	24-5/8	22-1/2	24	24	10-3/8	12	18-1/2
KSFV10FB	35	33-7/8	60-5/8	24-5/8	32-1/2	34	34	11-5/8	13-1/4	28-1/2
KSFV12FB	35	33-7/8	60-5/8	24-5/8	32-1/2	34	34	13-5/8	15-3/4	28-1/2
KSFV15FB	35	33-7/8	70	31-1/4	32-1/2	34	34	16-1/8	18-7/8	28-1/2
KSFV18FB	43-1/8	41-7/8	63-1/2	31-1/4	40-1/2	42	42	19-1/8	22-1/8	36-1/2
KSFV20FB	49-1/4	51-1/8	82	40-1/4	49	51-1/4	51-1/4	25	25-1/8	44-1/2

MODEL SIZE	WASHABLE INLET FILTERS		MERV 13 FILTERS	
	QTY	SIZE	QTY	SIZE
KSFV09FB	2	16X20X1	3	20X25X2
KSFV10FB	4	16X20X1	5	25X25X2
KSFV12FB	4	16X20X1	5	25X25X2
KSFV15FB	4	16X25X1	12	16X25X2
KSFV18FB	2	20X20X1	16	16X25X2
	2	20X25X1		
KSFV20FB	4	25X32X1	8	16X25X2
			8	25X25X2

SIDE DISCHARGE FILTERED UNITS

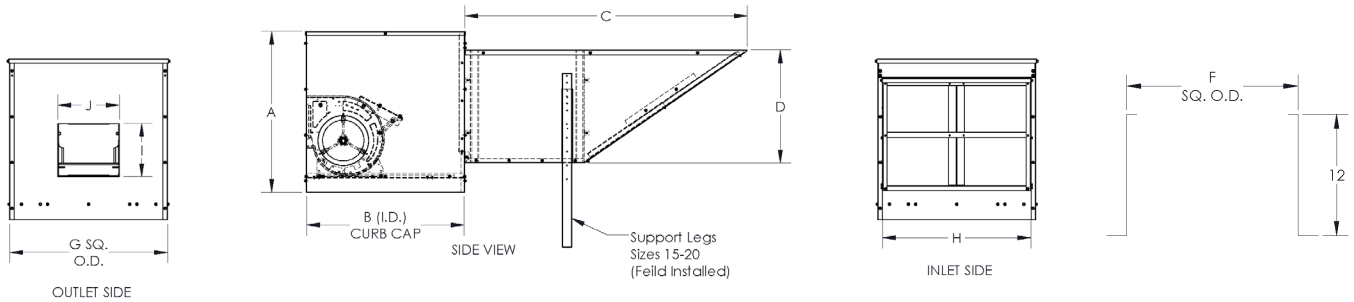

MODEL SIZE	A	B SQ.	C	D	F SQ.	G SQ.	H	I	J	DAMPER O.D.
KSFV09FB	30	23-7/8	45-5/8	24-5/8	22-1/2	24	24	10-3/8	12	18-1/2
KSFV10FB	35	33-7/8	60-5/8	24-5/8	32-1/2	34	34	11-5/8	13-1/4	28-1/2
KSFV12FB	35	33-7/8	60-5/8	24-5/8	32-1/2	34	34	13-5/8	15-3/4	28-1/2
KSFV15FB	35	33-7/8	70	31-1/4	32-1/2	34	34	16-1/8	18-7/8	28-1/2
KSFV18FB	43-1/8	41-7/8	63-1/2	31-1/4	40-1/2	42	42	19-1/8	22-1/8	36-1/2
KSFV20FB	49-1/4	51-1/8	82	40-1/4	49	51-1/4	51-1/4	25	25-1/8	44-1/2

MODEL SIZE	WASHABLE INLET FILTERS		MERV 13 FILTERS	
	QTY	SIZE	QTY	SIZE
KSFV09FB	2	16X20X1	3	20X25X2
KSFV10FB	4	16X20X1	5	25X25X2
KSFV12FB	4	16X20X1	5	25X25X2
KSFV15FB	4	16X25X1	12	16X25X2
KSFV18FB	2	20X20X1	16	16X25X2
	2	20X25X1		
KSFV20FB	4	25X32X1	8	16X25X2
			8	25X25X2



KSFV-FB Belt Drive Kitchen Supply Fan Filtered Units

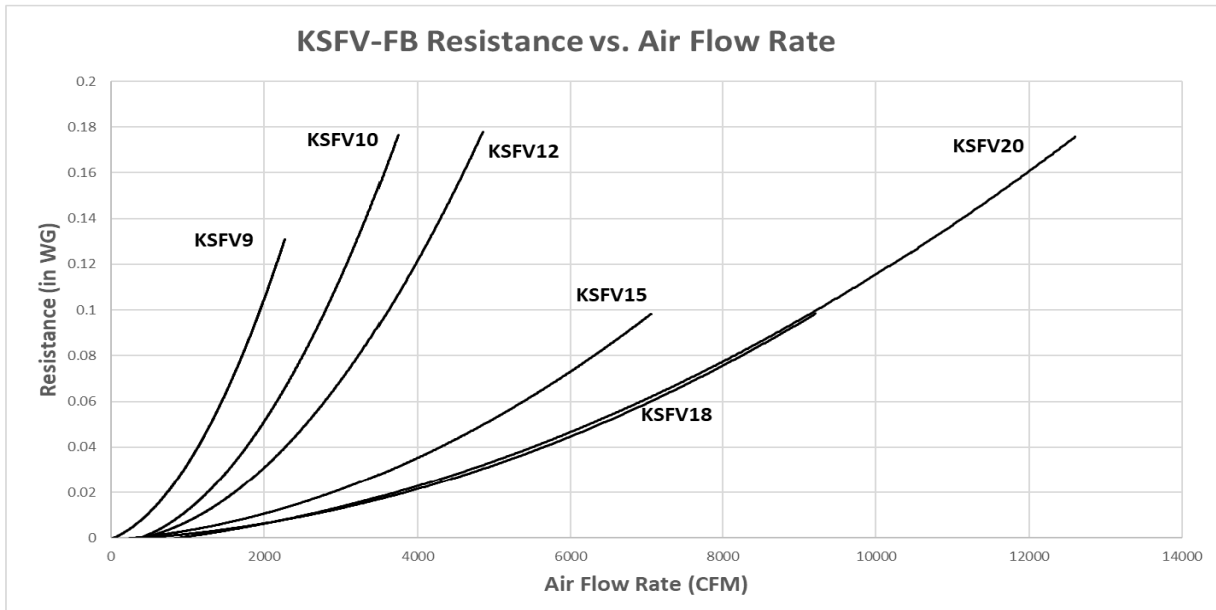

Use the estimated resistance graphs to help select the proper fan that will deliver the desired airflow. Enter the graph from the bottom at the specified CFM and move vertically upward to the fan curve for the desired size, then horizontally to the left and read the estimated resistance resulting from the filter box. Add the resistance to the system design to obtain the total resistance to be used for the proper fan selection.