

TRe90/H, TRe200, AND TRe300 ERV INSTALLATION, OPERATION & MAINTENANCE MANUAL

FOR SINGLE/MULTI-FAMILY
APPLICATIONS



Model: TRe300, TRe200, and TRe90 shown

⚠ CAUTION**RISK OF ELECTRIC SHOCK OR EQUIPMENT DAMAGE**

Whenever electrical wiring is connected, disconnected or changed, the power supply to the ERV and its controls must be disconnected. Lock and tag the disconnect switch or circuit breaker to prevent accidental reconnection of electric power.

⚠ CAUTION**RISK OF CONTACT WITH HIGH SPEED MOVING PARTS**

This appliance has two high speed fans that can cause injury or be damaged if objects come into contact with the impellers when they are spinning. The fans may be controlled by external controlling devices and switch on at any time. When working in the area of the fans, electric power to the unit must be disconnected.

IMPORTANT

All ductwork is to be designed and installed in accordance with SMACNA guidelines.

IMPORTANT

This ERV is intended for ducted ventilation only. Ducting at least 40 inches [1 meter] in length must be installed on all four airstreams.

⚠ CAUTION**RISK OF INJURY FROM FALLING OBJECTS**

Installation of this unit requires hoisting hardware overhead and working directly beneath heavy objects during the installation process. Observe all OSHA-approved work practices. Always wear OSHA-approved Personal Protective Equipment (PPE).

IMPORTANT

Only persons who have been properly trained and authorized are to access the ERV electrical box and the controller. Changes to the controller are to be made only by trained and authorized personnel.

IMPORTANT

This equipment is to be installed by following industry best practices and all applicable codes. Any damage to components, assemblies, subassemblies or the cabinet which is caused by improper installation practices will void the warranty.

READ AND SAVE THIS MANUAL/LIRE ET CONSERVER CE MANUEL

NOTICE

This manual has space for recording operating settings at time of unit commissioning that must be completed by the installer. See Sections 5.1 and 5.2 of this manual.

Information that is recorded is specific to just one ERV. If additional ERVs are being documented, please make copies of these pages and identify each copy by its unit tag.

UNIT INFORMATION

Record information as shown below. In the unlikely event that factory assistance is ever required, this information will be needed.

Locate the S&P unit label, to be found outside of the appliance, near the terminal block. Record the model and serial numbers below.

NOTE: This information is for purposes of identifying the specific air handling appliance. Unit-specific option data can then be obtained, as needed, from the Model Number.

ERV Model: TRe90 TRe90H
 TRe200
 TRe300

Serial Number:

UNIT INFORMATION

Part No.: TRe200_000		Serial Number: J200096S	
S&P		ETL LISTED CONFORMS TO UL STD 1812 CERTIFIED TO CANADIAN C22.2 No. 113 Intertek 4000510	
⚠ WARNING ⚠ AVERTISSEMENT			
 Danger of electrical shock. Always disconnect from power source before servicing.		Danger de choc électrique. Toujours déconnecter la source d'alimentation avant les réparations.	
Not for Outdoor Use pas pour une utilisation en extérieur			
120V 60HZ 1 Phase 2.5A		120V 60HZ 1 Phase 2.5A	
Unit:	MCA: 10	MFS: 10	Unit:
MCA: 10	MFS: 10	MCA: 10	MFS: 10
Motor: Qty 2: @ 0.11 HP & 1.22 F.L.A. Moteur: Qty 2: de chaque 0.11 CV & 1.22 A.P.C.			
Motors Thermally Protected		Moteurs protégés thermiquement	
Do not install in a cooking area or connect directly to any appliance.		Ne pas installer dans une zone de cuisson ou de se connecter directement à n'importe quel appareil.	
HVI CERTIFIED		CERTIFIED RATINGS Model TRe200 Complete ratings at: www.hvi.org	
Rated Air Flow @ 0.2 in wg (50Pa) 224 cfm 106 (L/s) 0.4 in wg (100Pa) 209 cfm 99 (L/s)			
Energy Performance	Adjustable Sensible Recovery Efficiency	Sensible Recovery Efficiency	Moisture Transfer
Net Supply Air Flow			
50 cfm (24 L/s) at 32°F (0°C)	83%	78%	69%
50 cfm (24 L/s) at 95°F (35°C)	61% Total Recovery Efficiency	63% Adjusted Total Recovery Efficiency	
Soler & Palau			
USA: Tel (800) 961-6370, Fax (800) 961-7070, www.solerpalau.com Canada: Tel (866) 738-0233, Fax (866) 338-5346, www.solerpalau.produ.com Mexico: Tel (52) (222) 2238 900, Fax (52) (222) 223 9914, www.soler-palau.com.mx			

UNIT LABEL (TYPICAL)

1.0 OVERVIEW	6	5.0 OPERATION	19
1.1 DESCRIPTION	6	5.1 MANOMETER READINGS AT COMMISSIONING	19
1.2 OPERATING MODES	6	5.2 AIRFLOW READINGS AT COMMISSIONING.....	19
1.3 UNIT WEIGHTS.....	7	5.2.1 Conversion of Pressure Drop to Airflow	19
2.0 COMPONENT DESCRIPTION	7	5.2.2 Continuous Mode (low speed)	20
2.1 CABINET	7	5.2.3 Boost Mode (high speed)	20
2.1.1 Removable Door with Interlock Switch	7	6.0 MAINTENANCE	20
2.2 FANS.....	7	6.1 MAINTENANCE AFTER 30 DAYS OPERATION	20
2.3 CONTROLLER	7	6.2 RECALIBRATION OF AIRFLOWS	21
2.4 DUCTS	8	6.3 DOOR REMOVAL	21
2.5 ENTHALPIC CORE	10	6.4 SERVICE PARTS.....	21
2.6 FILTERS	10	7.0 TROUBLESHOOTING	22
2.7 CONTROLS TERMINAL STRIP	10	7.1 INDICATION OF PROBLEM	22
3.0 UNIT PLACEMENT	11	7.2 TRe HAS AIRFLOW BUT IS MAKING NOISE	22
3.1 MOUNTING THE UNIT	11	7.3 NO APPARENT AIRFLOW FROM THE TRe.....	22
3.2 SERVICE CLEARANCES	11	7.4 INADEQUATE OR REDUCED AIRFLOW FROM THE TRe.....	23
3.3 AC POWER SOURCE.....	12	7.5 TRe FAILS TO RUN IN EITHER LOW SPEED OR HIGH SPEED MODE	23
3.3.1 TRe90, TRe200, TRe300	12	7.6 NO APPARENT REASON FOR LOW AIRFLOW	23
3.3.2 TRe90H.....	12		
3.4 LOAD BEARING CAPACITY OF SUPPORTS	12		
4.0 INSTALLATION	12		
4.1 USER-SUPPLIED INSTALLATION MATERIALS.....	12		
4.2 FACTORY-RECOMMENDED ELECTRIC SERVICE ENTRY.....	12		
4.2.1 TRe90, TRe200, TRe300	12		
4.2.2 TRe90H.....	12		
4.3 FACTORY-RECOMMENDED LOW-VOLTAGE SERVICE ENTRY.....	13		
4.4 ATTACHING DUCTS	13		
4.5 BALANCING AIRFLOWS	13		
4.6 WIRING SCHEMATICS.....	15		
4.7 LOW-VOLTAGE WIRING DIAGRAMS	17		
4.7.1 Single Speed Mode CONTINUOUS	17		
4.7.2 Low Speed CONTINUOUS/High Speed SWITCHED	17		
4.7.3 Single Speed Mode SWITCHED (Intermittent)	17		
4.8 DAMPER OPERATION	17		
4.8.1 Damper installation for Continuous ERV Operation	18		
4.8.2 Damper Installation for Intermittent ERV Operation	18		

TABLE OF ILLUSTRATIONS

Figure 1.2.0 TRe Cutaway View.....	6
Figure 2.1.0 Pressure Port Locations.....	7
Figure 2.4.0 Airstream Illustration.....	9
Figure 2.4.1 Separate Return Air Pick-up—Supply Air to Furnace Return Air Trunk	9
Figure 2.4.2 Separate return Air and Supply Air.....	9
Figure 2.4.3 Furnace Return Air Back into Return Air	9
Figure 2.4.4 Furnace Return Air Back into Supply Air	9
Figure 2.6.0 TRe Filter Locations	10
Figure 2.7.0 Controls Terminal Strip	10
Figure 3.1.0 Mounting the ERV to a Stud Wall	11
Figure 4.5.0 Pressure Port Locations	14
Figure 4.5.1 Fan Speed Control Potentiometers	14
Figure 4.6.0 TRe Wiring Schematic	15
Figure 4.6.1 TRe Hard-wired Wiring Schematic.....	16
Figure 4.7.0 Low-voltage Wiring Diagram 1	17
Figure 4.8.0 Low-Voltage Wiring Diagram 2	18
Figure 4.8.1 Low-Voltage Wiring Diagram 3.....	18
Figure 5.2.0 Pressure Drop to Airflow Conversions	20
Figure 6.4.0 TRe Service Parts	21

1.0 OVERVIEW

1.1 DESCRIPTION

The TRe ERVs are multi-speed air-to-air energy recovery ventilators that are designed for residential application and have multiple installation options. They can be suspended from floor joists, or they can be mounted on a wall or other object. Each type of installation can be accomplished by a single person. The TRe90, TRe200, and TRe300 have an integral line cord, ready to be plugged into a standard 120VAC receptacle. The TRe90H needs to be hard-wired by the installer.

The ERV exhausts stale Return Air (RA) while transferring both latent and sensible energy between an incoming fresh outdoor airstream (OA). Energy recovery is accomplished by a static plate heat exchanger core. Each airstream has a 120V EC fan, which provides airflow from 30 to 130 CFM for the TRe90/H, from 30 to 225 CFM for the TRe200, and from 30 to 280 CFM for the TRe300.

The airflow rate can be changed from Continuous to Boost at any time, using many different optional sensors or control devices.

The unit may operate with balanced or unbalanced airflow. However, balanced airflow provides the best energy recovery. Airflow can be adjusted using the motor potentiometers and the values read via the door pressure taps.

The hinged door has an opening for viewing and access to the potentiometers. The entire cabinet is lined with foil-backed 1" thick foam insulation.

1.2 OPERATING MODES

The TRe has two different operating modes: Continuous and Boost. Continuous mode should be set to provide the minimum ventilation requirement. Boost mode can be used to supply and exhaust a greater volume of air, up to 130 CFM for the TRe90/H, up to 225 CFM for the TRe200, or 280 CFM for the TRe300.

The two operating modes are selectable and controlled independently so that different controlling methods can be used to switch back and forth. Example: an IAQ sensor could be used to switch the unit to Boost mode.

 **NOTE:** This unit is an Energy Recovery Ventilator, or ERV. It is commonly referred to throughout this manual as an ERV.

 **NOTE:** Sensible energy is often referred to as "heat energy."

 **NOTE:** Latent energy is often referred to as "moisture energy."

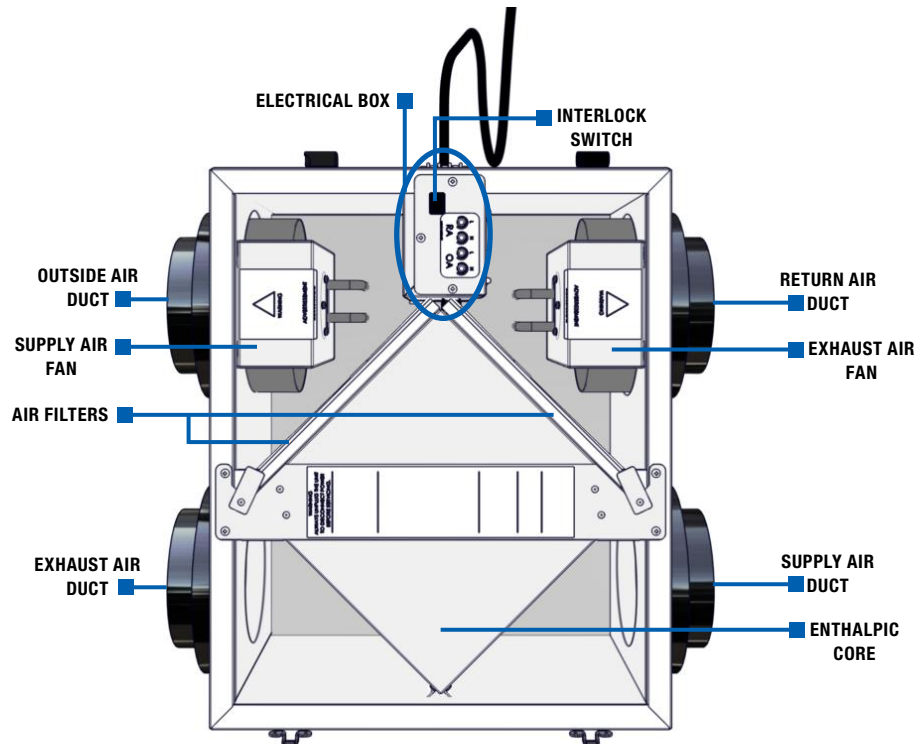

FIGURE 1.2.0 TRe CUTAWAY VIEW

1.3 UNIT WEIGHTS

The hanging weight of each TRe90/H is approximately 32 pounds.
The hanging weight of each TRe200 is approximately 36 pounds.
The hanging weight of each TRe300 is approximately 52 pounds.

The shipping weight of each TRe90/H is approximately 38 pounds.
The shipping weight of each TRe200 is approximately 48 pounds.
The shipping weight of each TRe300 is approximately 66 pounds.

2.0 COMPONENT DESCRIPTION

2.1 CABINET

The cabinet is built of 22 gauge (0.64 mm) galvanized steel and is painted white. It has a hinged, removable door. The exterior of the unit boasts four air pressure test ports, one low-voltage terminal strip, an access/viewing port, and locations for four duct connectors, (6" or 8", shipped loose).

2.1.1 Removable Door with Interlock Switch

The insulated access door is hinged on one side and has two securing latches on the other side. The hinges are separable to allow for removal of the access door for servicing. The door has an access/viewing port built in to permit adjustment of the fan potentiometers. Directly behind the access door is a pressure-sensitive interlock switch that will shut off power to the unit if the door is opened during operation. Also installed on the door are four air pressure test ports, used for connecting a manometer and taking air pressure measurements.

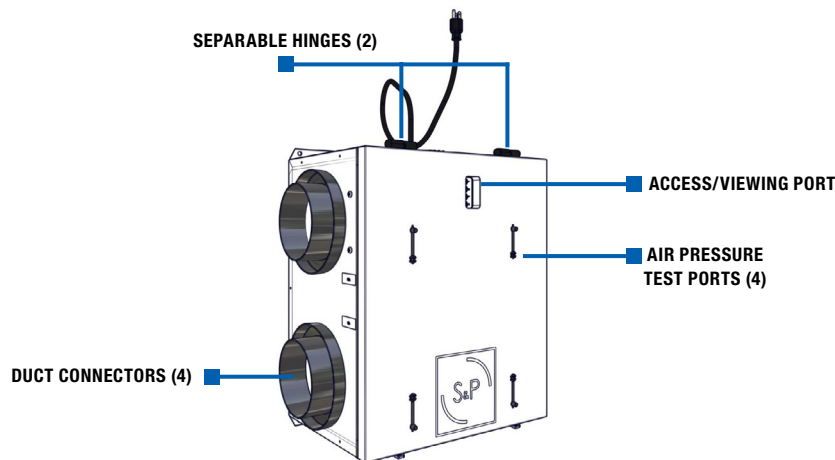

FIGURE 2.1.0 PRESSURE PORT LOCATIONS

2.2 FANS

The TRe has two advanced, high efficiency electronically commutated (EC) 120VDC variable speed fans. One fan is used for intake air (Outdoor Air/Supply Air) and the other fan is for the exhaust airstream (Return Air/Exhaust Air). The speed of each fan is controlled independently by a 0–10VDC signal from the controller.

2.3 CONTROLLER

The controller provides the signal to the EC motors using integral potentiometers. Incoming line voltage powers both fans and also a step-down Class II transformer which provides 24VAC to the externally-mounted low-voltage terminal strips. The controller has four potentiometers that are adjusted by the user to establish fan speeds for each operation mode.

2.4 DUCTS



NOTE: If you wish to install the unit in an attic or other unconditioned space, you must insulate all of the unit's ductwork that is located in the attic. Use at least R-6 insulation.

IMPORTANT

It is important to understand and use the equipment airstream terminology as it is used in this manual. The airstreams are defined as:

- **Outside Air (OA):** Air taken from the external atmosphere and, therefore, not previously circulated through the system.
- **Supply Air (SA):** Air that is downstream of the enthalpic core and is either supplied to the occupied space or to an additional conditioner.
- **Conditioned Air (CA):** Air that is supplied to an occupied space.
- **Return Air (RA):** Air that is returned to a heating or cooling appliance from a conditioned space.
- **Exhaust Air (EA):** Air that is removed from a heating or cooling appliance and discharged.

TRe units are supplied with a set of 4 duct connectors that must be field-installed. The connectors can be used for either 6" round or 8" round ducts. It is preferable to keep duct runs short and straight to maximize performance.

For all installations, SMACNA guidelines for duct installation should be followed. The most commonly-used ducting is 6" diameter flexible due to ease of installation, sound attenuation, and cost, however, rigid ducting is preferred because there is less resistance to airflow, resulting in less power consumption to deliver the same amount of air.

A total of four duct runs will generally be used:

- One duct will provide clean outdoor air (Outside Air) to the TRe. This duct will normally be capped by an air inlet cap mounted on the exterior side wall of a residence and equipped with a bird screen.

Wall intakes must be located at least 10' from any appliance vent or any vent opening from a plumbing drainage system. Wall intakes must also be 10' from any exhaust fan discharge outlet unless that outlet is 3' or more above the intake location. (IRC 2006, Section M1602.2)

- One duct will be needed to exhaust stale air (Exhaust Air) to the outdoors. This duct will normally end at an exhaust cap located on an exterior wall of a residence.
- One duct will be needed to deliver fresh, conditioned air (Supply Air) from the TRe to a desired location in the residence. The Supply Air duct may end in a floor or wall grate with an area of at least 28 square inches. Alternatively, the Supply Air duct may be connected directly into the return air duct or the supply air duct for the main heating and cooling system. When connecting to the main return air duct, it must be at least 3' from the return plenum to minimize suction from the furnace blower.
- One duct is used to collect indoor air (Return Air), running from return grilles through the energy exchange core in the TRe before being exhausted to the outdoors.

If the TRe is located in a conditioned space, only the OA and EA ducts need to be insulated.

If it is installed in an unconditioned space such as an attic or crawl space, the SA, OA, RA, and EA ducts must be insulated.



NOTE: Ducts inside a building that are connected to the outside must be insulated with a sealed vapor barrier on both the inside and the outside of the insulation.

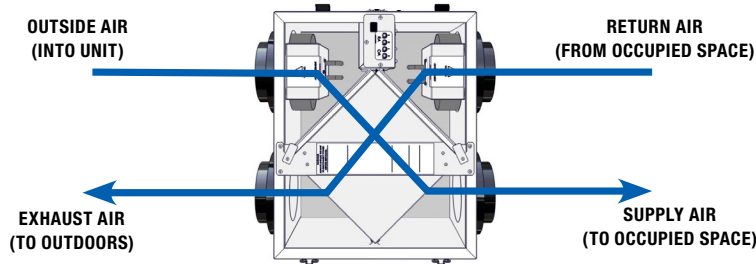

FIGURE 2.4.0 AIRSTREAM ILLUSTRATION

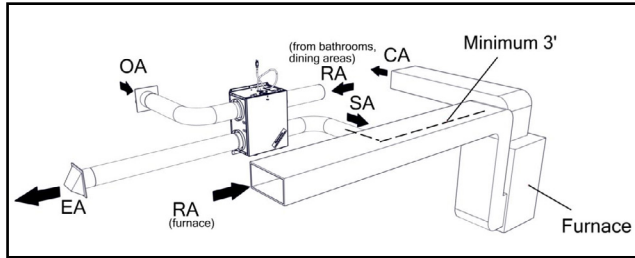

FIGURE 2.4.1 SEPARATE RETURN AIR PICK-UP—SUPPLY AIR TO FURNACE RETURN AIR TRUNK

NOTE: ERV blower may be operated separate from furnace blower.

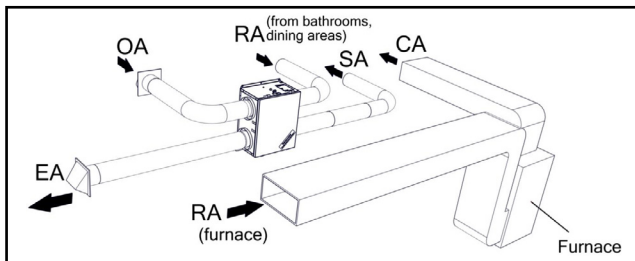

FIGURE 2.4.2 SEPARATE RETURN AIR AND SUPPLY AIR

NOTE: ERV blower may be operated independently from furnace blower. Use caution to introduce SA at low velocity and where good mixing will occur to minimize discomfort from drafts.

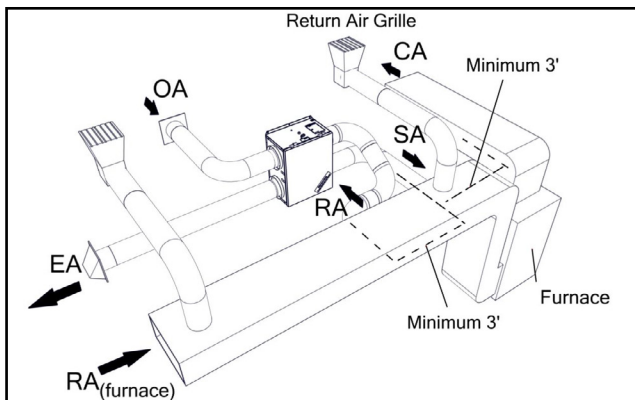

FIGURE 2.4.3 FURNACE RETURN AIR BACK INTO RETURN AIR

NOTE: For the setup in Figure 2.4.3, the furnace blower must be operated any time the ERV is operated. Use furnace fan “on” continuous low speed or optional FM control to cycle furnace fan on ERV.

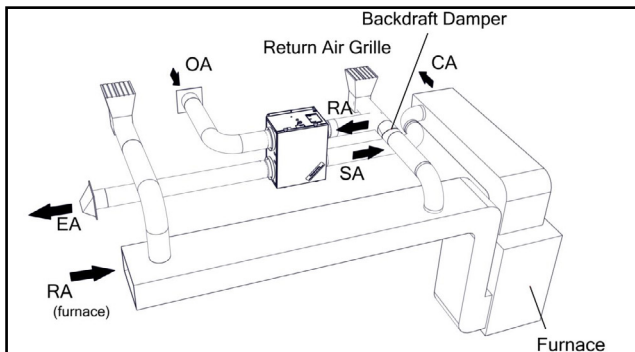

FIGURE 2.4.4 FURNACE RETURN AIR BACK INTO SUPPLY AIR

NOTE: ERV blower may be operated separate from furnace blower.

NOTE: The cores used in all ERVs are static plate enthalpic cores. They are commonly referred to in this manual as “cores.”

2.5 ENTHALPIC CORE

Each TRe has a static-plate, cross-flow core separates the outgoing, polluted indoor airstream from the incoming supply airstream—while simultaneously transferring total energy (heat and water vapor) between the two. Airstreams do not mix, and pollutants are not transferred across partition plates.

2.6 FILTERS

Each TRe is equipped at the factory with mesh-type anti-microbial MERV 8 filters on both the OA and RA sides of the core. If desired, the mesh-type OA filter can be replaced with an optional MERV 13 pleated paper filter accessory, which will ship loose.

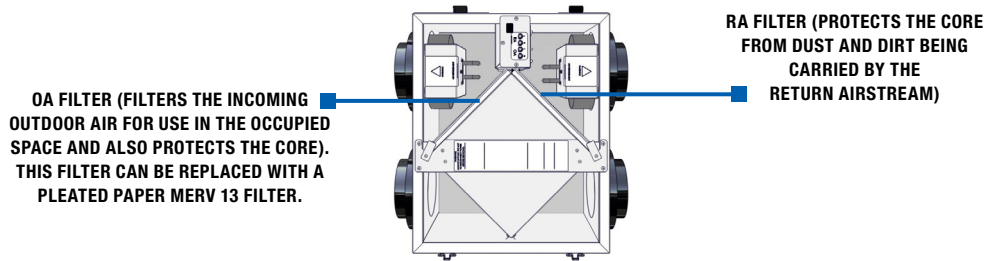

FIGURE 2.6.0 TRe FILTER LOCATIONS

2.7 CONTROLS TERMINAL STRIP

A single terminal strip is located at the end of each TRe, providing a 24VAC connection to Boost mode or to control accessories. For detailed information, see the Low-Voltage Wiring Diagrams in Section 4.8 of this manual.

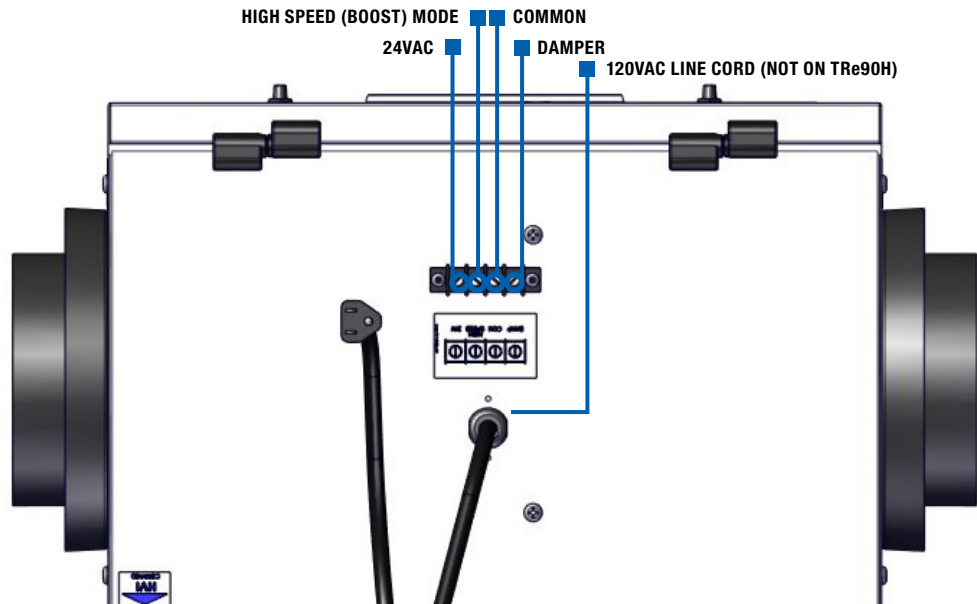

FIGURE 2.7.0 CONTROLS TERMINAL STRIP

3.0 UNIT PLACEMENT

RenewAire recommends installation of the TRe by a professional HVAC installer with knowledge of local building codes who is able to properly balance the air streams prior to use. The TRe can be installed by one person.

3.1 MOUNTING THE UNIT

- ♦ **UNIT MAY BE INSTALLED IN ANY ORIENTATION**

Orient the unit for the simplest duct layout and connections.

May be installed in any position providing sufficient clearance as shown in the front of this manual. Preferred position is horizontal so that the hinged access door can swing down to allow for easiest filter changes and cleaning of the enthalpic core.

- ♦ **MOUNTING THE TRe ON A CONCRETE FOUNDATION WALL OR STUD WALL**

Mount hanging bracket to the wall with appropriate concrete anchors. Use pre-cut foam tape from small parts bag. Remove backing and apply two pieces of foam tape equally spaced along the unit's mounting flange to be held by the hanging bracket. Apply the other two pieces of foam over two holes that will be used for fastening, on the other flange. The tape should be applied in a "U" shape to cushion both the front and back of the integral flanges.

Lift unit and slide unit flange into the hanging bracket. Using metal flat washers, fasten flange opposite hanging bracket to structure. Safety screws should similarly be installed passing through the hanging bracket and flange. Make sure the screws, which you must supply, are properly selected for the loads and substrate involved, 2" x #10 pan head screws are recommended.

- ♦ **SUSPENDING THE TRe FROM FLOOR JOISTS OR TRUSSES**

The unit may be screwed directly to joists or trusses using the hanging bracket and integral flange. Mount as described for mounting to concrete foundation wall.

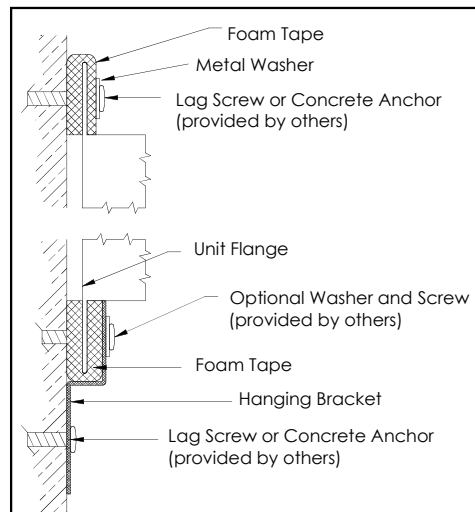

FIGURE 3.1.0 MOUNTING THE ERV TO A STUD WALL

3.2 SERVICE CLEARANCES

Primary consideration is sufficient space to open door latches and for the door to be able to swing open at least 90°. See the dimensioned drawing in the front of this manual for required clearances.

NOTE: If you wish to install the unit in an attic or other unconditioned space, you must insulate all of the unit's ductwork that is located in the attic. Use at least R-6 insulation.

NOTE: The door is equipped with slide-off hinges. For the homeowner's convenience, it is helpful to orient the unit so that the door is easily removed when unlatched.

NOTE: Do not over-tighten the screws. Compression of the gasket may result in vibration transfer.

NOTE: Wall brackets must be supported by two wall studs. If the desired location of the TRe does not permit support by two wall studs, the TRe must be mounted on a user-supplied 3/4" thick plywood panel that is anchored on two wall studs.

CAUTION
Risk of injury when lifting unit and installing it overhead.

3.3 AC POWER SOURCE

3.3.1 TRe90, TRe200, TRe300

Power requirements: 120VAC, 3.0 amps

The TRe90, TRe200, and TRe300 have an integral 34" long power supply cord. The installer must provide a standard, grounded 120VAC outlet in the proximity of the ERV. Check all local codes.

3.3.2 TRe90H

Power requirements: 120 VAC, 3.0 amps

The TRe90H are to be hard-wired by the installer. Check all local codes before wiring. A disconnect switch on the AC supply line may be required.

3.4 LOAD BEARING CAPACITY OF SUPPORTS

The TRe ERV is to be installed by attachment to building structural members such as joists, bar joists, beams, wall studs, and columns. It is not to be supported by attachment to fixtures such as ductwork or air handlers unless the fixtures are permanently installed and capable of providing adequate support. Whenever an ERV is installed on or supported by a fixture, the installation must be approved by a design engineer.

4.0 INSTALLATION

⚠ CAUTION

RISK OF INJURY FROM FALLING OBJECTS

Installation of this unit requires hoisting hardware overhead and working directly beneath heavy objects during the installation process. Observe all OSHA-approved work practices. Always wear OSHA-approved Personal Protective Equipment (PPE).

4.1 USER-SUPPLIED INSTALLATION MATERIALS

RenewAire suggests the use of a duct hoist for hoisting the TRe into position.

For all installations:

- Medium-strength thread-lock,
- UL-181—rated mastic for duct connections,
- Common hand tools such as pliers, drill, screwdriver bits, stud finder, etc.

4.2 FACTORY-RECOMMENDED ELECTRIC SERVICE ENTRY

4.2.1 TRe90, TRe200, TRe300

The TRe90, TRe200, and TRe300 have a factory-installed 34" line cord that will need to be plugged into a 120V receptacle for operation.

4.2.2 TRe90H

The TRe90H are to be hard-wired by the installer. Entry of electric supply wiring is to be through the junction box provided on the unit. The junction box measures 2" x 2" and contains 4" of free length of wire leads. There are 2 knockouts on opposite sides of the junction box that support 1/2" trade size metal conduit. Junction box can be remounted 90 degrees to reposition the knockouts as necessary. It may be easier to mount the unit and connect to the junction box before installing the provided duct collars and ductwork.

4.3 FACTORY-RECOMMENDED LOW-VOLTAGE SERVICE ENTRY

All low-voltage connections are made on the exterior of the unit on the low-voltage terminal strip. Field-installed low-voltage wiring does not enter the unit.

4.4 ATTACHING DUCTS

Ducts are to be fabricated and installed per SMACNA guidelines. Use a combination of zip ties, UL-181—rated duct mastic and then secure the duct from slipping off by means of a screw, positioned behind one or more ribs in the duct. Observe Industry Best Practices when installing and supporting the ducts.

4.5 BALANCING AIRFLOWS

TRe ERVs provide the ability to deliver and exhaust completely balanced airflows, or to modify them as desired. While balanced airflow is preferred, many owners will prefer to have a slight imbalance, providing a slight excess of Outdoor Air to reduce air infiltration into a home. Some homes may require an imbalance because a furnace or water heater is not direct-vented. Again, an HVAC professional will be able to advise balance settings that will best address the circumstances in each home.

Balancing an airflow is done by setting the Outdoor Air fan speed and then adjusting the Return Air fan speed to eject the same or somewhat less air to the outdoors.

Equipment required for testing airflows:

- A magnehelic gauge (or manometer) or other device capable of measuring 0–1.0 inches water gauge of differential pressure.
- 2 pieces of natural rubber latex tubing, 1/8" I.D., 1/16" wall thickness works best.

Manometers are relatively inexpensive devices that are readily available from online retailers; accuracy within the range of 0–1.0 in. w.g. is the critical measure. Water manometers generally have graduations of 0.1" that are difficult to accurately determine. For all manometers, there are two plastic tubes that connect at the manometer and then the other ends go to pressure ports on the TRe.

Individual differential static pressures (DP) are measured ACROSS the core and filters, using the installed pressure ports located on the removable door.



NOTE: Airflow volumes can be changed at any time by the user as experience dictates. Whenever changing airflow volumes for either Continuous (low speed) or Boost (high speed) modes, the fans should again be balanced.

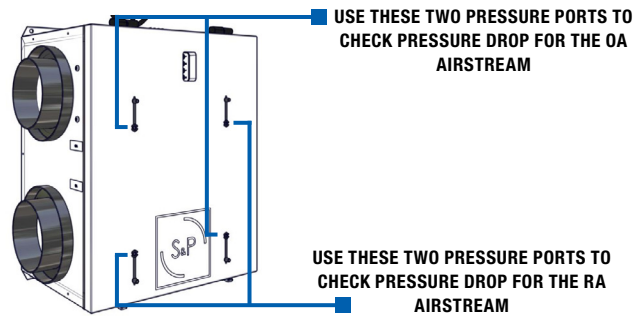

FIGURE 4.5.0 PRESSURE PORT LOCATIONS

- Verify the unit has clean filters in place.
- Open the pressure port caps for the OA airstream and then insert the tubing into the openings about 1".
- Take a differential pressure reading for the OA airstream by installing the “high” pressure side (+) of the measuring device to the OA port and the “low” pressure side (-) to the SA port. Compare the pressure drop to the chart in section 5.2.1 to obtain the CFM. Adjust the fan speed potentiometer (See figure 4.5.1) to obtain the desired CFM. Enter the CFM information in the box in section 5.2.2.
- Take a differential pressure reading for the RA airstream by installing the “high” pressure side (+) of the measuring device to the RA port and the “low” pressure side (-) to the EA port. Compare the pressure drop to the chart in section 5.2.1 to obtain the CFM. Adjust the fan speed potentiometer (See figure 4.5.1) to obtain the desired CFM. Enter the CFM information in the box in section 5.2.2.
- Install a jumper on the low-voltage terminal to force the unit into Boost (high speed) mode. See the wiring diagram in Section 4.6.
- Repeat the process for both airstreams to set both the CFM and balance. Enter the information in the boxes in Section 5.1.
- After adjusting the potentiometers, take additional readings as needed to verify that fan speed settings are correct. See Figure 4.5.1.

NOTE: Adjust low speed fan settings by using the potentiometers marked “L.” Adjust high speed fan settings by using the potentiometers marked with “H.”



FIGURE 4.5.1 FAN SPEED CONTROL POTENTIOMETERS

4.6 WIRING SCHEMATICS

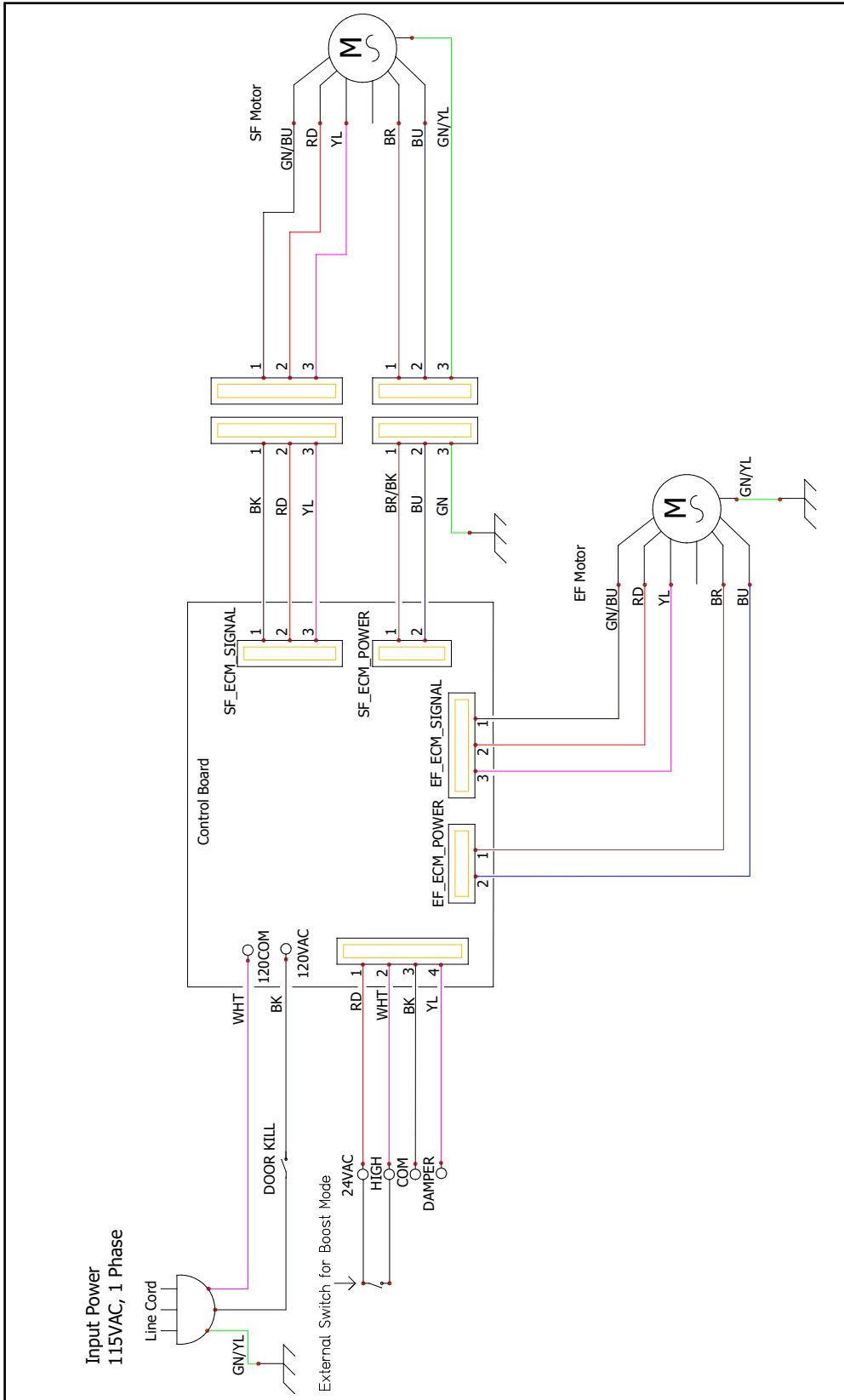

FIGURE 4.6.0 TRe WIRING SCHEMATIC

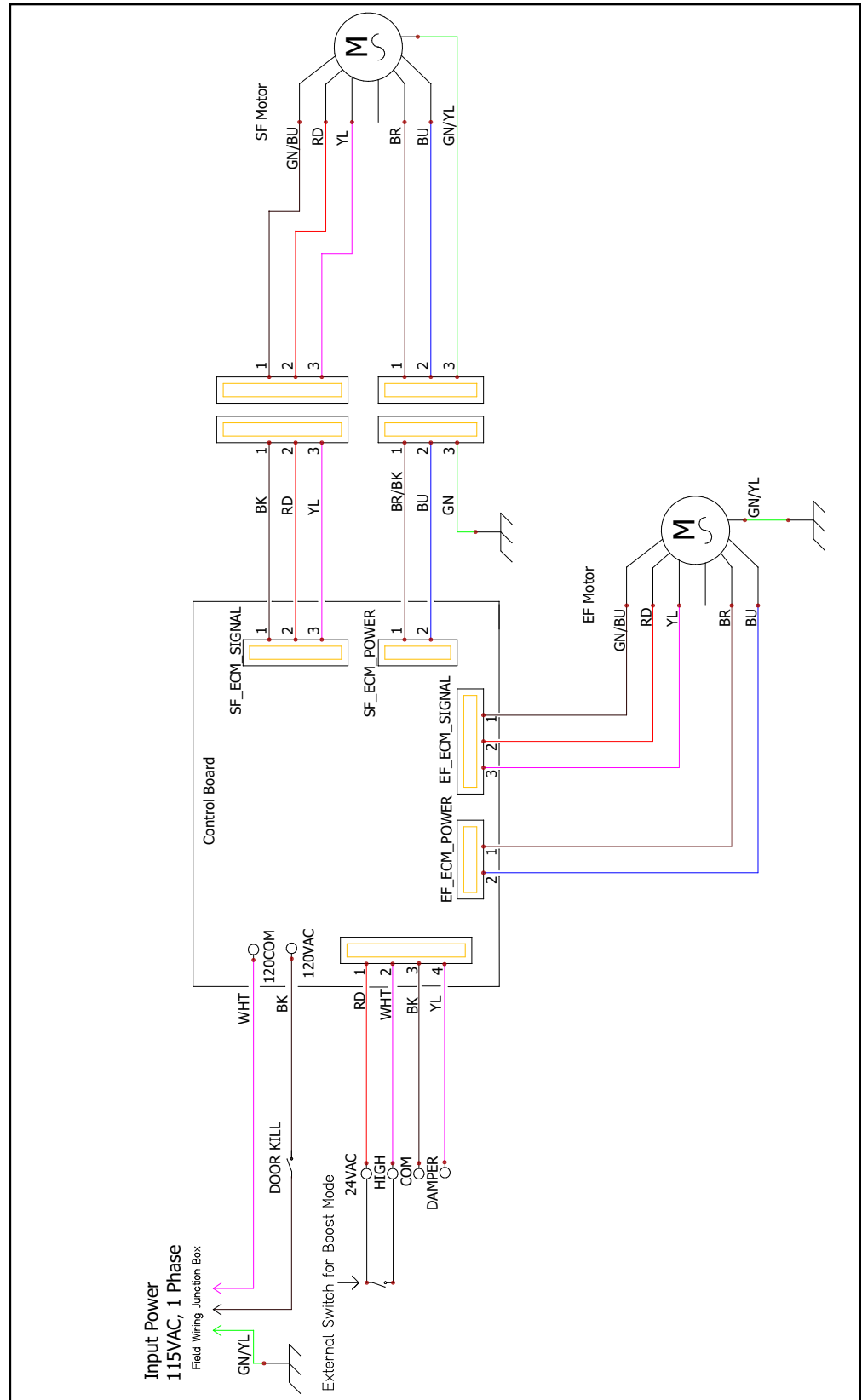

FIGURE 4.6.1 TRe HARD-WIRED WIRING SCHEMATIC

4.7 LOW-VOLTAGE WIRING DIAGRAMS

4.7.1 Single Speed Mode CONTINUOUS

When plugged in, the unit will run constantly at Low Speed. If the unit is to operate constantly at a single airflow, adjust the OA and RA low speed potentiometers to the desired airflow as described in section 4.6. The high speed potentiometers are not needed for this application.

4.7.2 Low Speed CONTINUOUS/High Speed SWITCHED

The TRe can be installed to run constantly at Low Speed (Continuous mode) and then switch periodically to Boost Mode in response to a controlling device. To achieve this, the external controlling device, such as a SPBT control or an occupancy sensor that is to trigger Boost mode (High Speed), is connected to the 24VAC terminal and to the High Speed terminal.

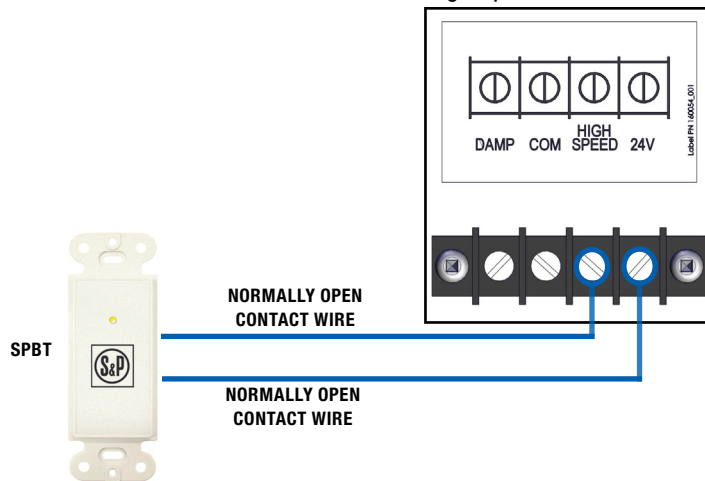

FIGURE 4.7.0 LOW-VOLTAGE WIRING DIAGRAM 1

If multiple controls are desired to operate the unit in Boost mode for different purposes, they may be wired in parallel. The unit control board provides 12VA so the combined power demand for desired accessories must be lower than this threshold. For example, a SPBT controller may be wired to an TRe unit and up to 6 SPBL controls may be connected to the SPBT PB terminals in parallel. For additional information see the installation manuals for the control(s) you select for wiring diagrams and specific instructions.

4.7.3 Single Speed Mode SWITCHED (Intermittent)

If the unit is to operate intermittently without a continuous flow, an external controlling device will need to be used as in figure 4.7.0. To achieve this operation, turn the low speed potentiometers fully counterclockwise and connect the desired controlling accessory to the 24V and High Speed terminals on the unit. Set the high speed potentiometers to the desired flow rate for the intermittent operation. When the unit is plugged in, there will be no airflow until the control accessory signals the unit to operate in High Speed mode.

4.8 DAMPER OPERATION

When the ERV is connected to a ducted return of the HVAC system, outdoor air may be pulled through the ERV via the HVAC fan. This can be prevented by installation of a damper installed at the fresh air outlet of the ERV. A 24V normally closed motorized damper can be wired to a TRe unit for this purpose.

4.8.1 Damper installation for Continuous ERV Operation

If the ERV is set up to provide continuous airflow, a 24V damper can be wired to the 24VAC and COM terminals on the unit terminal block. The damper will open whenever the unit has 120VAC power and close when power is lost.

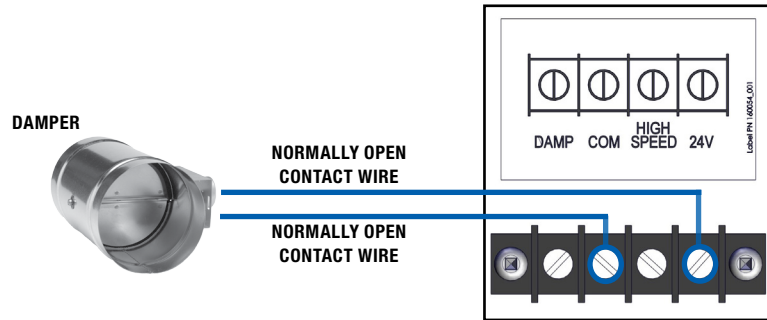

FIGURE 4.8.0 LOW-VOLTAGE WIRING DIAGRAM 2

4.8.2 Damper Installation for Intermittent ERV Operation

If the ERV is intended to operate intermittently as described in section 4.7.3, turn the low speed potentiometers fully counterclockwise and wire a control to the 24V and High speed terminals. Wire the damper to the DAMP and COM terminals. The unit will remain off, and the damper closed until the control activates the high speed terminal. When the High Speed terminal is activated, the unit fans will operate at the flow corresponding to the High Speed potentiometers and the damper will open.

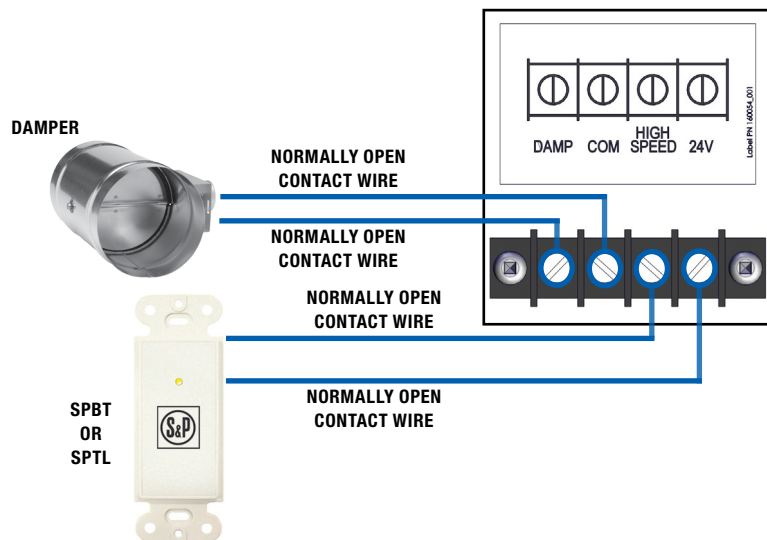

FIGURE 4.8.1 LOW-VOLTAGE WIRING DIAGRAM 3

5.0 OPERATION

5.1 MANOMETER READINGS AT COMMISSIONING

Return Air Pressure Port	In. w.g.:	<input type="text"/>	Pressure Drop:	<input type="text"/>
Exhaust Air Pressure Port	In. w.g.:	<input type="text"/>		
Outside Air Pressure Port	In. w.g.:	<input type="text"/>	Pressure Drop:	<input type="text"/>
Supply Air Pressure Port	In. w.g.:	<input type="text"/>		

5.2 AIRFLOW READINGS AT COMMISSIONING

5.2.1 Conversion of Pressure Drop to Airflow

See the tables below.

(Units equipped with clean MERV 8 filters.)

To determine the airflow in CFM, obtain the manometer readings shown above and calculate the differences between them. Then apply the following formula to convert the readings to CFM:

TRe90/H: [Airflow in CFM] = 183 x [Pressure Drop in inches w.g.]

TRe200: [Airflow in CFM] = 283 x [Pressure Drop in inches w.g.]

TRe300: [Airflow in CFM] = 593 x [Pressure Drop in inches w.g.]

EXAMPLE: 1 In. w.g. of pressure drop corresponds to 283 CFM, 0.5 In. w.g. corresponds to 141.5 CFM, and so on for the TRe200.

(Units equipped with a MERV 13 filter in the OA airstream. Formulas below are for OA airstream only.)

TRe90/H: [Airflow in CFM] = 154 x [Core Pressure Drop in inches w.g.]

TRe200: [Airflow in CFM] = 235 x [Core Pressure Drop in inches w.g.]

TRe300: [Airflow in CFM] = 487 x [Core Pressure Drop in inches w.g.]

EXAMPLE: 1 In. w.g. of pressure drop across the core corresponds to 235 CFM, 0.5 In. w.g. corresponds to 117.5 CFM, and so on for the TRe200.

TRe90/H			TRe200		
Pressure Drop (In. W.G.)	Airflow with MERV 8 Filters (CFM)	Airflow with MERV 13 Filters (CFM)	Pressure Drop (In. W.G.)	Airflow with MERV 8 Filters (CFM)	Airflow with MERV 13 Filters (CFM)
0.1	18	15	0.1	28	24
0.2	37	31	0.2	57	47
0.3	55	46	0.3	85	71
0.4	73	62	0.4	113	94
0.5	92	77	0.5	142	118
0.6	110	92	0.6	170	141
0.7	128	108	0.7	198	165

TRe300		
Pressure Drop (In. W.G.)	Airflow with MERV 8 Filters (CFM)	Airflow with MERV 13 Filters (CFM)
0.1	59	49
0.2	119	97
0.3	178	146
0.4	237	195

FIGURE 5.2.0 PRESSURE DROP TO AIRFLOW CONVERSIONS

5.2.2 Continuous Mode (low speed)

Outdoor Airflow: CFM

Return Airflow: CFM

5.2.3 Boost Mode (high speed)

Outdoor Airflow: CFM

Return Airflow: CFM

IMPORTANT

This unit is only to be used after completion of building construction. It is not to be used during construction.

6.0 MAINTENANCE

The primary maintenance requirement is filter replacement. Filters are not to be cleaned, they must be replaced. The standard filter as shipped from the factory is a mesh-type, anti-microbial MERV 8. These standard filters are NOT to be sprayed with filter treatments or dust adhesives. The standard mesh-type OA MERV 8 filters may be replaced with pleated paper MERV 13 filters post-construction, if desired. Both filters should be replaced every three months, or more frequently, if needed, based on the cleanliness of the OA and RA air entering the unit.

The enthalpic core should be vacuumed annually. Remove the hinged access door by sliding it horizontally on its pin hinges and then remove the filters for access to the core. Use a soft-bristled nozzle on a good vacuum and carefully vacuum the inlet faces of the core.

Ducts should be inspected annually. Ensure all ducts and joints are free from damage, contaminants, or leaks in order for the system to behave properly.

6.1 MAINTENANCE AFTER 30 DAYS OPERATION

After 30 days of unit operation, check/tighten all mounting and support hardware. Inspect filters for cleanliness. There is often construction dust collected during initial operation. If filters appear dirty, replace them.

6.2 RECALIBRATION OF AIRFLOWS

Whenever there is a reconfiguration of the heating system in a residence, to include changing damper positions, the fan speed potentiometers on the TRe should be re-calibrated for optimum performance. If the residence undergoes significant structural changes, such as an addition to the home, the TRe should also be re-calibrated. If optional MERV 13 filters are installed, recalibration is also required.

6.3 DOOR REMOVAL

The hinged door is held in place by two separable hinges on one edge and two security latches on the other edge. The separable hinges have a spring-loaded detent to prevent accidental separation. To remove the door, first disconnect power to the unit. Unlatch and open the door and then strike the edge of the door, pushing the door toward the OA/EA side of the unit.

6.4 SERVICE PARTS

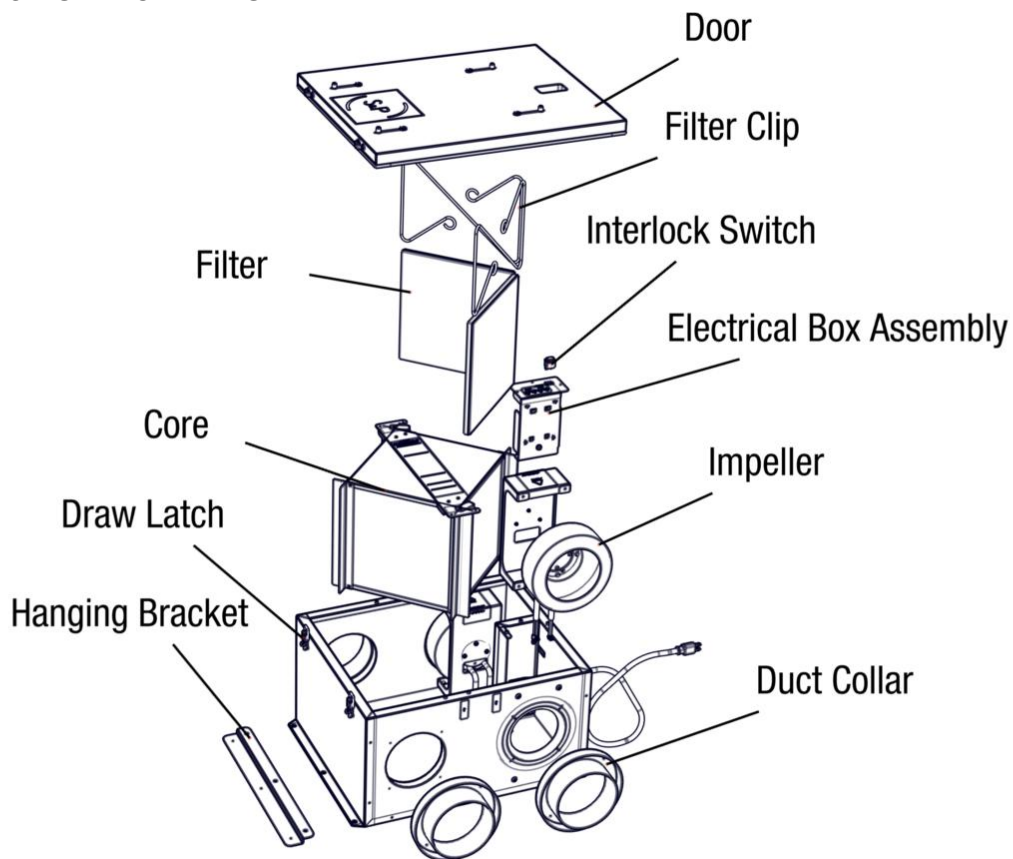

FIGURE 6.4.0 TRe SERVICE PARTS

⚠ CAUTION

Many of the troubleshooting steps described herein require working with or near live high-voltage. Take appropriate precautions against electric shock and use Personal Protective Equipment (PPE) as a safeguard. Wear gloves, safety glasses and protective head gear, as necessary.

7.0 TROUBLESHOOTING**7.1 INDICATION OF PROBLEM**

Indications of a problem with the ERV may be the perception that fresh air is not being delivered. The first step in resolving an apparent problem with an TRe ERV is to verify that there actually is a problem.

Regardless of the reason for thinking there is a problem with the TRe, the first steps in troubleshooting are to check the air filters to make sure they're clean and properly positioned, and then do a hard restart of the unit. A hard restart involves unplugging the unit for several seconds and then plugging it back in. It takes a few moments for the control board to discharge. After reapplying power, check to see if resetting the circuit has solved the problem.

Because there are many different ways of ducting the Supply Air into a dwelling, it's often difficult to say with certainty that the fresh air provided by the TRe is not reaching its intended destination or if the ERV is simply no longer providing enough fresh air. Determine where and how the fresh air is supposed to be delivered—if it is being carried in a dedicated duct directly to the air outlet, check for airflow at the outlet.

- Verify that dampers are still correctly positioned (open). If the ERV is being ducted into a main air handling system, shut the air handling system down so that airflow at the ducts can be detected.
- Check for airflow at the air openings nearest to the TRe, not at the far end of the house. It may be necessary to hold a thin strip of tissue paper in front of a vent to realize whether or not there is airflow.
- Check for airflow in both low speed and high speed settings. It will be easier to detect airflow in the high speed setting.
- Check ducts and duct runs and problems with bends, sagging, etc.

7.2 TRe HAS AIRFLOW BUT IS MAKING NOISE

Feel the TRe while it is running to see if there is excessive vibration from the fans. Fan noise and vibration can be caused by an imbalance in the rotors or possibly by a bad bearing. Turn off power to the unit and rotate the fan impellers by hand. Make sure impellers rotate freely. Use wet swabs to clean any dust/dirt buildup off the impeller blades. If problem continues, a fan may have a bad bearing.

7.3 NO APPARENT AIRFLOW FROM THE TRe

If it seems that there is no apparent airflow, verify that it has power.

- If it does not have power, trace the power supply back to its source and isolate the problem or symptoms. Look for a switch turned off, a blown fuse or a tripped circuit breaker. If necessary, use a multimeter to trace the power supply and isolate the problem.
- If it has power and the fans will not run, disconnect all power to the unit and check the disconnect switch with an ohmmeter.
- If it has power, check to see if the fans are running by listening for fan noise and feeling the unit for vibration from the fans.
- If it has power and the fans are running, **CHECK THE FILTERS TO MAKE SURE THEY ARE CLEAN.** Check the entire length of the ducts, all the way from the outdoor vent hoods to the indoor vent openings. Make sure a duct has not fallen off or that a flexible duct has not been pinched. In rare cases, there may be obstructions inside the duct. Look to see if a louver in an outdoor vent cap is stuck or blocked or if an indoor louver has been shut.
- If it has power but only one fan is running, disconnect all power to the unit and check the fan connectors to make sure they are still making contact.

7.4 INADEQUATE OR REDUCED AIRFLOW FROM THE TRe

If the unit has power and both fans are running, use a manometer to check the pressure differential across the core. See Section 4.5 Balancing Airflows in this manual. The results of a pressure differential test will provide correct information on how much air the unit is moving and also how the volume of air compares to when the unit was first installed. Check both low speed and high speed settings by changing the jumpers on the low-voltage terminal strip, as shown in section 4.7 in this manual. Check ducts for bends, blockages, or leaks.

7.5 TRe FAILS TO RUN IN EITHER LOW SPEED OR HIGH SPEED MODE

The low-speed and high-speed modes operate independently of each other so there can be a failure in just one mode and it does not appear in the second mode. If one mode does not work, the problem can be isolated to either the controlling device or to an internal failure by bypassing the controlling device.

- Remove all wiring from the terminal strip as shown in Section 4.7 of this manual. Mark the wires so they can be reconnected in their proper locations.
- With no jumper present, check for proper operation.
- Install a jumper wire from the 24VAC terminal to the High Speed terminal. Check for proper operation. Remove the jumper wire and reinstall the control device wiring.

7.6 NO APPARENT REASON FOR LOW AIRFLOW

The final step in troubleshooting an ERV problem is to reset the fan potentiometers. Use a manometer and follow the instructions in Section 4.5 Balancing Airflows in this manual. Restore the pressure differential settings to their original airflow settings (CFM), as recorded in Section 5.1.

USA

(800) 961-7370
FAX: (800) 961-7379
6393 POWERS AVE
JACKSONVILLE, FLORIDA
32217 USA
WWW.SOLERPALAU-USA.COM

CANADA

(416) 744-1217
FAX: (416) 744-0887
6710 MARITZ DRIVE, UNIT 7
MISSISSAUGA, ON L5W 0A1, CANADA
WWW.SOLERPALAU CANADA.COM