



MODEL TUB

TUBEAXIAL UPBLAST PROPELLER ROOF EXHAUSTER



MODEL FEATURES

- Exhaust air up to 60,116 CFM in static pressure applications up to 1" w.g.
- Straight-through air flow design results in maximum exhaust efficiency
- Motor and drives are located outside of the exhaust airstream
- Belt drives permit easy performance adjustments when needed
- cULus 705 Listed

MODEL OVERVIEW

Model TUB is designed for high capacity industrial and commercial roof exhaust applications. The remote drive configuration of the TUB is especially suited for the removal of fumes, vapors, steam, dust, smoke and contaminated or heated air. Belt drive models are available for continuous operation in air temperatures to 200°F. For temperature ratings to 1000°F and/or IRI requirements refer to Model TUB-HT

Capacities range from 6,210 to 60,116 CFM and up to 1" static pressure. Fan selections are available in 24, 30, 36, 42, 48, 54 and 60 inch sizes. Horsepowers range from 3/4 to 15HP. Blade selections are available in aluminum, steel, or fiberglass reinforced polypropylene (see capacity charts for performances). Units are tested in accordance with AMCA 301 (sound) and AMCA 210 (air) in an AMCA certified laboratory. Every unit is completely assembled and factory tested for quality assurance prior to shipment.

2 year fan housing warranty, 1 year motor warranty



CONSTRUCTION FEATURES AND OPTIONS

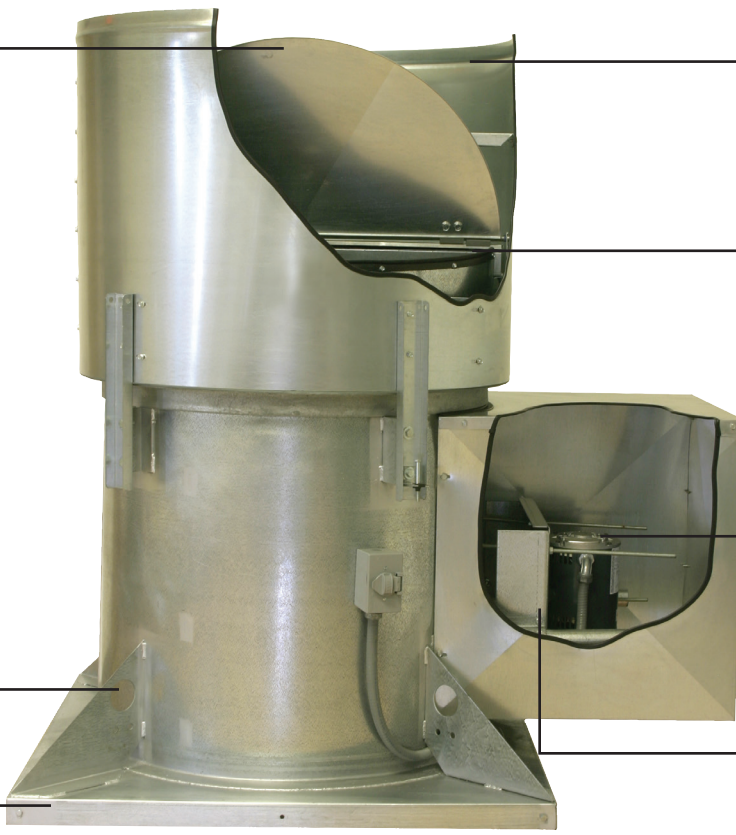

Butterfly Dampers

Available in steel or fiberglass.

Blades

Statically and dynamically balanced aluminum airfoil extrusion or polypropylene propellers for optimum performance. High temperature fans use steel blades.

Damper Bearings

Damper doors pivot on a galvanized steel shaft rotating in two bronze bushings.

Lift Points

For easy, safe roof placement.

Curb Cap

Heavy-gauge galvanize with integral inlet.

Bearings & Shaft

200,000 hour bearings and turned, ground and polished shafting.

Factory Run & Tested

Assures dependable operation.

Windband

Heavy-gauge galvanized steel.

Rain Channel

Galvanized metal channel section drains water out of the fan area when the damper doors are closed.

Motors

ODP, 2-speed, TEFC, corrosion duty, or explosion proof.

Motor Slide Base

For ease of belt adjustment.

Drives

Variable pitch through 3HP and fixed pitch sheaves 5HP and larger. High temperature fan uses minimum dual groove sheaves.

CONSTRUCTION/SPECIFICATION CHECKLIST

Construction

The TUB series is built with heavy-gauge steel to provide years of reliable service. Tubes 24-60" (to 10HP) are G-90 galvanized steel. Sizes 24-60" have rolled 2" flanged ends.

The TUB series is also available in aluminum construction sizes 24-48" with welded aluminum angle flanges on each end.

Upblast fans include a heavy-gauge galvanized steel windband with pressure operated damper doors. A galvanized channel section drains water out of the fan area when the damper doors are closed.

All fans are available in epoxy, heresite or polyester resin finishes. Special colors can be ordered. Contact your representative for the cost and finish best suited for your application.

Blades

For versatility, blades are offered in special high-strength, adjustable pitch aluminum airfoil, or adjustable pitch fiberglass reinforced polypropylene. TUB units with special steel blades are available upon request. These styles were selected to provide optimum performance and strength at low to moderate noise levels. Refer to the performance tables for the best selection.

The adjustable pitch aluminum airfoil propeller performs over a wide range of static pressures. This blade's strength is derived from matching T-6061 extruded aluminum airfoil sections to a heavy steel plate hub. All S&P blades are statically and dynamically balanced.

The highly corrosive resistant polypropylene blade's efficiency is due to the uniform twisting of the airfoil section over its entire length, resulting in less turbulence. The operating parameters are -40°F to 185°F ambient temperatures. Hubs are produced from die cast aluminum resulting in a light weight, high strength factory adjustable pitch blade.

Drives

This belt drive model comes with 200,000 hour L50 relubricable pillow block bearings and remote grease lines as a standard feature. Bearings and drives are isolated from the airstream by bolted, heavy-gauge galvanized belt tubes and bearing covers. Belt drive models through 3HP ship with variable pitch pulleys; over 3HP have fixed pulleys. The motor base slides for easy belt adjustment. All units are factory assembled and test run for quality assurance.

Motors

Motors used in the TUB series are heavy-duty, nationally recognized, with nationwide service centers. Standard motors are open drip-proof (ODP). High efficiency, totally enclosed fan cooled (TEFC), explosion proof, and corrosion duty motors are available as an option.

Fan shafts shall be turned, ground and polished steel coated with an anti-rust compound to resist corrosion.

OPTIONS/ACCESSORIES

Roof Curb: Prefabricated heavy-gauge galvanized steel, welded construction, 12" high with 1-1/2" wood nailer. Options include burglar bars, single and double pitch construction, and additional curb heights.

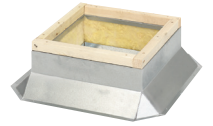

Outlet Guard: 1/2" x 1" wire mesh guard will prevent birds and other objects from entering fan.

Inspection Door: For inspection and blade service/cleaning.

Magnetic Latches: Helps reduce damper chatter when the unit is not in operation.

Heat/Smoke Vent: Opens damper doors when temperatures exceed 165°F. Allows heat and smoke to escape building without use of fan power.

Disconnect Switch: Nonfused safety disconnects are available for all motor sizes in rain-tight or open enclosures.

Aluminum Construction: Optional aluminum construction available on windbands, curb caps, panel and blades.

Special Coatings: Powered roof exhausters often require special coatings for protective and decorative purposes. Available coatings include: Synthetic Resin, Epoxy, and Heresite (air-dried phenolic). Contact your representative or the factory for more information on available coatings and colors.

DIMENSIONS

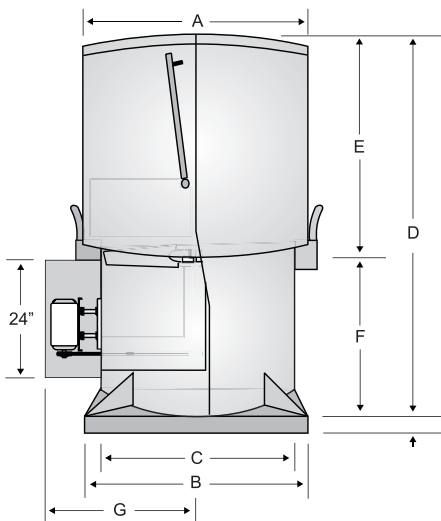

Model TUB	Dimensions (Inches)						
	A O.D. Windband	B sq. I.D. Curb Cap	C sq. Min. I.D. Opg	D Height	E Windband Height	F Tube Height	G (Max.)
24	30	35	25-1/8	55-1/2	25	30-1/2	37
30	36	41	31-1/8	58-1/2	28	30-1/2	40
36	42	47	37-1/8	60-1/2	30	30-1/2	43
42	48	53	43-1/8	65-1/2	33	32-1/2	46
48	54	59	49-1/8	68-1/2	36	32-1/2	49
54	60	65	55-1/8	71-1/2	39	32-1/2	52
60	66	71	61-1/8	74-1/2	42	32-1/2	55

Model TUB	Metal Gauges			Average Weight
	Fan Housing	Wind Shroud	Curb Cap	
24	12	18	14	500
30	12	18	14	600
36	12	18	14	1000
42	12	18	14	1100
48	10	18	14	1300
54	10	18	14	1580
60	10	18	10	1700

**PERFORMANCE****Model TUB-A - Belt Drive - Aluminum Blade**

Model TUB	CFM / BHP @ Static Pressure								HP	RPM	No. of Blades	Max. BHP	Sones @ 5 ft.
	0	1/8	1/4	3/8	1/2	5/8	3/4	1					
24	6210	5807	5171	4321	-	-	-	-	3/4	1200	3	0.83	19
	6805	6443	5948	5201	4415	-	-	-	1	1315	3	1.09	24
	7840	7537	7162	6651	5979	5306	4519	-	1-1/2	1515	3	1.65	29
	8668	8398	8081	7688	7156	6544	5936	4531	2	1675	3	2.22	38
30	9035	8175	6911	-	-	-	-	-	3/4	915	3	0.83	23
	9973	9213	8219	6789	-	-	-	-	1	1010	3	1.11	24
	11405	10755	9989	8955	7664	6304	-	-	1-1/2	1155	3	1.65	32
	12590	12009	11351	10554	9495	8312	7079	-	2	1275	3	2.21	38
	14318	13813	13262	12642	11903	10974	9935	7778	3	1450	3	3.22	45
36	13854	12440	10596	-	-	-	-	-	1	815	3	1.10	20
	15894	14689	13275	11404	9161	-	-	-	1-1/2	935	3	1.66	26
	17424	16337	15110	13611	11713	9660	-	-	2	1025	3	2.19	30
	19719	18769	17734	16568	15162	13476	11652	-	3	1160	3	3.14	36
	23798	23021	22201	21324	20373	19306	18074	15197	5	1400	3	5.47	68
	27028	26347	25639	24897	24114	23277	22371	20220	7-1/2	1590	3	7.97	89
42	14588	-	-	-	-	-	-	-	3/4	550	4	0.84	22
	16046	14024	11621	-	-	-	-	-	1	605	4	1.04	23
	18300	16539	14632	12265	-	-	-	-	1-1/2	690	4	1.57	24
	20157	18561	16898	14949	12723	-	-	-	2	760	4	2.11	29
	23074	21682	20029	18749	16978	15038	12727	-	3	870	4	3.28	36
	27349	26140	24961	23751	22474	21049	19441	15994	5	1030	4	5.17	45
	32037	30976	29849	28647	27358	25974	24473	21207	7-1/2	1310	3	7.87	57
48	20266	16694	-	-	-	-	-	-	1	500	4	1.12	24
	23104	20044	16726	-	-	-	-	-	1-1/2	570	4	1.67	25
	25536	22821	19815	16733	-	-	-	-	2	630	4	2.25	26
	29184	26863	24237	21647	18899	14356	-	-	3	720	4	3.33	35
	34656	32749	30623	28375	26210	23907	21375	-	5	855	4	5.51	43
	39519	37871	36068	34141	32163	30271	28304	23692	7-1/2	975	4	7.88	51
54	45327	43576	41742	39672	37424	35052	32652	28246	10	1175	4	10.87	73
	31028	26996	23045	19851	-	-	-	-	3	600	4	3.09	33
	38951	35127	30055	26760	24164	18353	-	-	5	710	4	5.32	44
	44741	41411	37455	32829	29414	26206	20758	-	7-1/2	850	3	7.91	54
60	49215	46040	42878	38781	34681	31975	29019	18913	10	935	3	10.89	62
	33008	22992	-	-	-	-	-	-	3	485	3	3.15	38
	39133	31577	24734	-	-	-	-	-	5	575	3	5.18	39
60	44918	38963	30343	27344	-	-	-	-	7-1/2	660	3	8.15	51
	49342	44124	36563	31592	-	-	-	-	10	725	3	10.93	59

Contact factory for alternate selections if required.

The sound ratings shown are loudness values in fan sones at 5 ft. (1.5m) in a hemispherical free field calculated per AMCA Standard 301 @ free air.

Brake horsepower does not include drive losses.

Values are installation Type A, free inlet fan sone levels.

Performance shown is for types and units without inlet or outlet ducts.

**Model TUB-P - Belt Drive - Polypropylene Blade**

Model TUB	CFM / BHP @ Static Pressure								HP	RPM	No. of Blades	Max. BHP	Sones @ 10 ft.
	0	1/8	1/4	3/8	1/2	5/8	3/4	1					
24	6350	5962	5491	4980	-	-	-	-	3/4	1275	6	0.75	17
	6998	6680	6180	5755	5268	4595	-	-	1	1390	6	1.00	20
	8265	7943	7615	7267	6873	6421	5382	-	1-1/2	1615	6	1.50	26
	9246	8996	8697	8408	8190	7731	6942	5382	2	1800	6	2.00	36
	10626	10323	10121	9875	9619	9342	8731	8042	3	2050	6	3.00	39
30	8697	7942	6919	-	-	-	-	-	3/4	975	6	0.75	19
	9775	9121	8323	7321	-	-	-	-	1	1080	6	1.00	20
	11515	10920	10321	9646	8797	7870	-	-	1-1/2	1250	6	1.50	24
	12821	12222	11727	11224	10523	9719	7823	-	2	1375	6	2.00	26
	14525	14029	13623	13124	12628	12031	10741	8914	3	1550	6	3.00	34
	17514	17112	16694	16301	15913	15491	14631	13585	5	1850	6	5.00	52
36	14809	13921	12488	11222	8630	-	-	-	1-1/2	930	6	1.50	24
	16823	16002	14911	13692	12481	10275	-	-	2	1040	6	2.00	28
	19331	18540	17681	16791	15710	14722	11081	-	3	1180	6	3.00	34
	22940	22026	21560	20890	20018	19230	17450	15008	5	1385	6	5.00	39
	26230	25850	25120	24562	23900	23243	21900	20144	7-1/2	1585	6	7.50	50
	29020	28671	28028	27670	27016	26560	25048	24010	10	1750	6	10.00	71
42	17451	15670	13561	10019	-	-	-	-	1-1/2	750	6	1.50	20
	19563	17981	16195	14986	10126	8126	-	-	2	825	6	2.00	32
	22893	21562	20128	18673	16892	14457	-	-	3	950	6	3.00	33
	27670	26551	25253	24030	22968	21616	18018	12775	5	1130	6	5.00	39
	31120	30830	30039	29130	28312	27022	24790	21100	7-1/2	1300	6	7.50	50
	34310	33537	32610	31674	30880	29868	27986	25708	10	1420	6	10.00	53
48	20303	18249	15126	-	-	-	-	-	1-1/2	620	8	1.50	24
	21414	19321	16364	-	-	-	-	-	2	650	8	2.00	26
	25236	23381	21684	19291	16061	-	-	-	3	750	8	3.00	28
	30791	29108	27464	25852	24142	22122	15276	-	5	890	8	5.00	36
	35748	34126	32561	31213	29792	28382	24298	18203	7-1/2	1015	8	7.50	50
	39574	38235	36780	35453	34243	33033	30691	26405	10	1120	8	10.00	55
54	31896	28991	24252	-	-	-	-	-	3	600	6	3.00	26
	34454	33006	31283	28892	25962	22632	-	-	5	730	8	5.00	33
	40051	38596	37383	35663	33543	31323	25762	-	7-1/2	835	8	7.50	39
	44750	43544	42334	41124	39504	37683	33343	28192	10	925	8	10.00	43
	51252	50115	49105	48094	46974	45764	42334	38593	15	1040	8	15.00	56
60	44454	40914	37683	33704	28292	-	-	-	5	640	6	5.00	36
	52235	49105	46274	43344	40015	35963	-	-	7-1/2	735	6	7.50	39
	58295	55465	52735	50015	47484	44354	-	-	10	810	6	10.00	50
	60116	58695	57185	55565	54055	52535	49205	45164	15	926	8	15.00	56

Contact factory for alternate selections if required.

The sound ratings shown are loudness values in fan sones at 5 ft. (1.5m) in a hemispherical free field calculated per AMCA Standard 301 @ free air.

Brake horsepower does not include drive losses.

Values are installation Type A, free inlet fan sone levels.

Performance shown is for types and units without inlet or outlet ducts.