



Model SQB

Inline Centrifugal Fan



MODEL SQB

BELT DRIVE SQUARE INLINE CENTRIFUGAL DUCT FAN



MODEL FEATURES

- Exhaust air up to 24,000 CFM in high static pressure applications up to 3-1/2" w.g.
- Belt drives permit easy performance adjustments when needed
- Ideal for applications where space is limited
- Non-overloading backward inclined wheel for efficiency at higher static pressures
- AMCA Air and Sound Licensed
- cULus 705 Listed

APPLICATION CONSTRUCTION OPTIONS

MODEL NAME	TYPICAL APPLICATIONS
SQB	Removal of clean air in general applications
SQBHP	High Pressure version of SQB

MODEL OVERVIEW

Model SQB fans are available in sizes 7 through 42, moving from 100 to over 24,000 CFM, with high static pressure capabilities to 3-1/2". SQB units are the perfect selection for clean air applications where space is a leading consideration. The compact housing, with removable access doors (2), can be mounted in any orientation.

CONSTRUCTION FEATURES AND OPTIONS

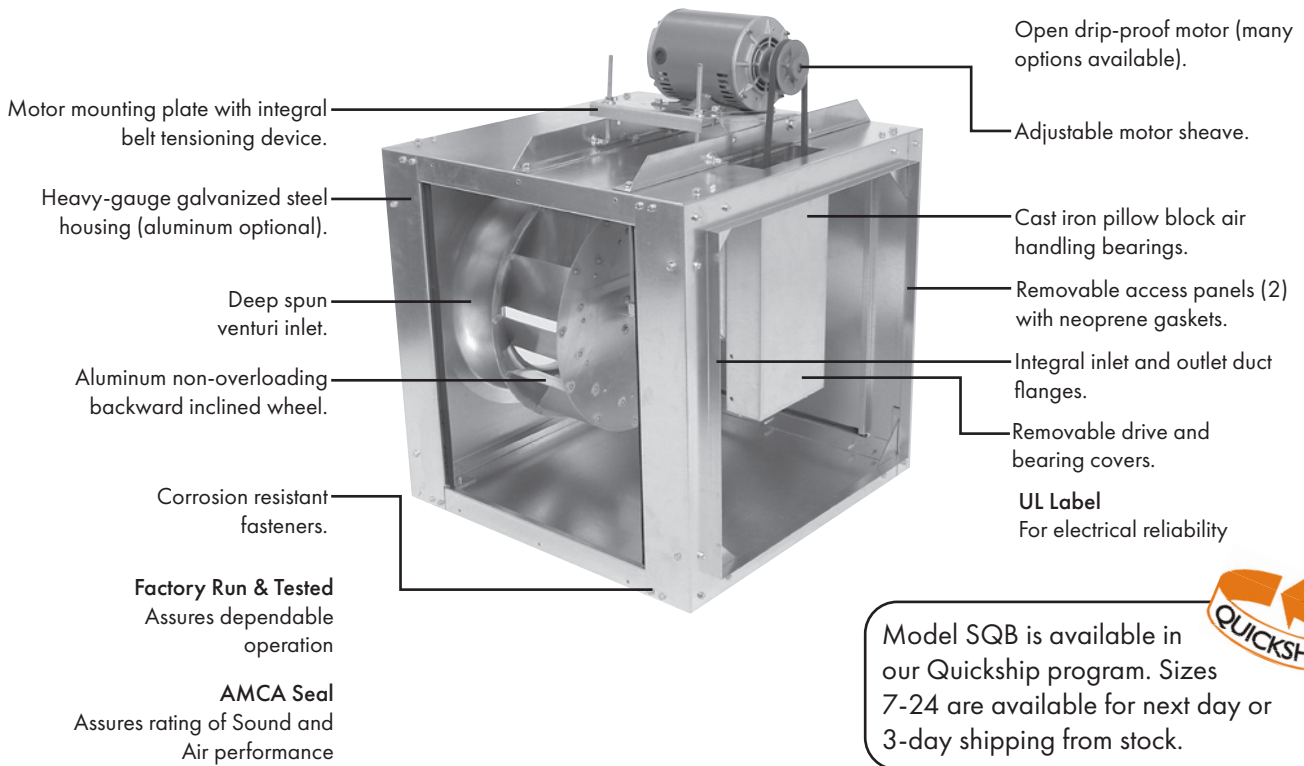

QUICKSHIP

Model SQB is available in our Quickship program. Sizes 7-24 are available for next day or 3-day shipping from stock.

2 year fan housing warranty, 1 year motor warranty

CONSTRUCTION/SPECIFICATION CHECKLIST

Blower/Housing

- Aluminum, non-overloading, backward inclined centrifugal wheel statically and dynamically balanced.
- Deep spun venturi inlet.
- Heavy-gauge galvanized steel housing.
- Integral inlet and outlet duct collars.
- Universal mounting - horizontal, vertical, or any angle.
- Motors and drives out of the airstream.
- Removable drive and bearing covers for easy access.
- Easy access to interior of unit with removable side panels (two per unit) with closed cell neoprene gasketing.
- Motor, drives, wheel, shaft, and bearings removable from unit without disconnecting duct.
- Motor mount plate with integral belt tensioning device.

Shaft and Bearings

- Precision turned, ground, and polished steel fan shaft and keyed.
- Self aligning cast iron air handling pillow block bearings with re-lube fitting, double sealed and pre-lubricated, designed for 200,000 hour life, L50.

Motor and Drives

- Permanently sealed ball bearing type motor furnished to the specified voltage, phase, and enclosure.
- Open drip-proof is standard. Two speed, totally enclosed, and explosion proof motors can be specified for most models.
- Drives are specified for a minimum of 150% of driven horsepower. Cast iron motor pulleys are factory set to the required RPM and are adjustable for final system balancing.
- Disconnect switch standard on single speed drip-proof and totally enclosed motors.

Certifications

- AMCA - the AMCA Seal on all units assures certified rating of air and sound performance.
- cULus - most models are available as listed by Underwriters Laboratories under Standard 705 when specified.



OPTIONS/ACCESSORIES

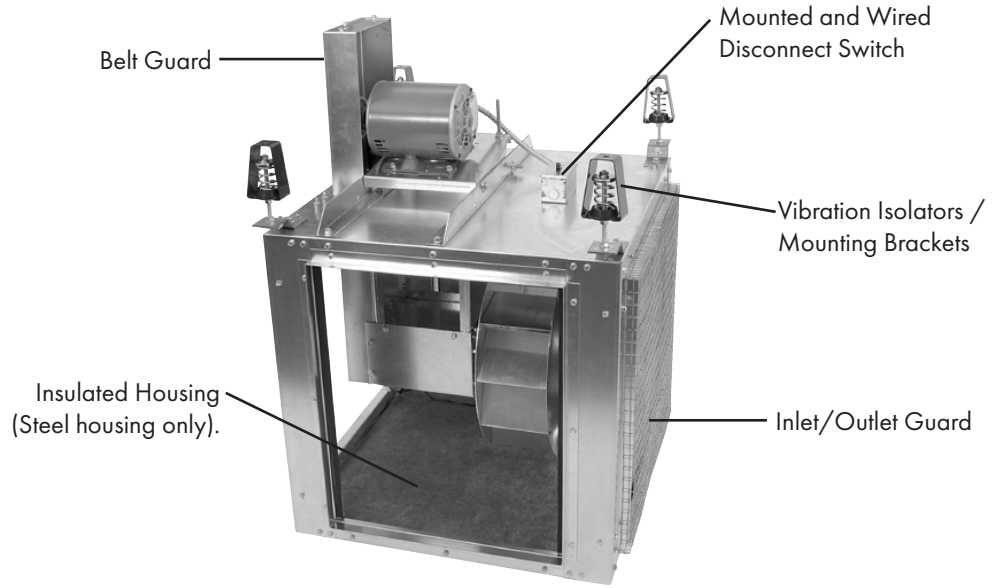

External Grease Fittings



Mounted and Wired Disconnect

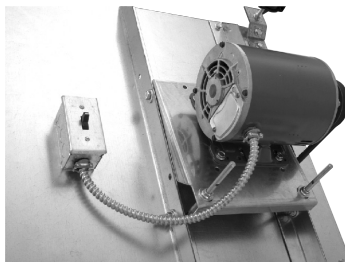

Side Discharge

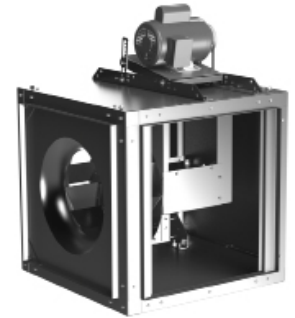

Belt Guard

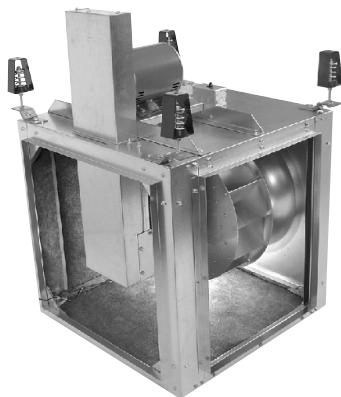

Motor Cover



Inlet/Outlet Guard



**Hanging Bracket/Mounting Foot
with Hanging Spring Isolator**



Hanging Spring Isolators



Hanging Rubber in Shear Isolators



Assorted Disconnects

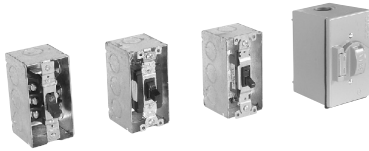

Heavy-duty Disconnect



Backdraft Damper



Insulated Housing

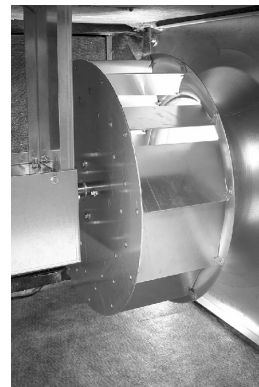

FILTER BOX OPTIONS



Features

- Designed for use with SQB Fans
- Designed to handle 1" or 2" filters
- Galvanized or aluminum construction up to size 24
- Galvanized construction sizes 30-42
- Standard filter is washable aluminum
- MERV 7 (1") or MERV 8 (2") disposable pleated filters available by special quote
- Removable side panels for easy access to filters

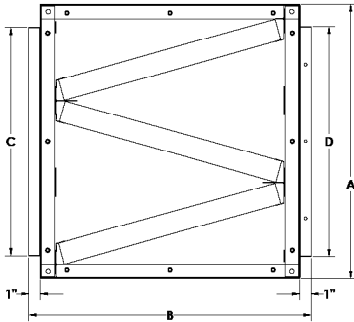

Dimensions - Filter Box with 1" Aluminum Filters

Fan Size	Filter Box Dimensions				Avg. Ship Wgt. (lbs)		No. of Filters	1" Filter Nominal Size
	A	B	C	D	Galv.	Alum.		
07-08	25	25	11-7/8	12	28	15	2	15x20x1
10	18	24-1/2	13-7/8	14	35	17	2	16x20x1
12	22	29-1/8	17-7/8	18	48	24	2	20x25x1
15	24	24-5/8	21-7/8	22	47	23	3	20x25x1
18	28	24-5/8	23-7/8	24	62	31	4	20x25x1
20	32	29-1/8	27-7/8	28	72	36	6	16x25x1
24	39	29-1/8	34-7/8	35	96	47	6	20x25x1
30	44	30-3/8	39-7/8	40	131	-	8	20x25x1
36	52	27-1/8	47-7/8	48	149	-	10	20x25x1
42	58	32-1/8	53-7/8	54	180	-	15	20x25x1

Dimensions - Filter Box with 2" Aluminum Filters

Fan Size	Filter Box Dimensions				Avg. Ship Wgt. (lbs)		No. of Filters	2" Filter Nominal Size
	A	B	C	D	Galv.	Alum.		
07-08	25	25	11-7/8	12	29	16	2	15x20x2
10	18	24-1/2	13-7/8	14	37	19	2	16x20x2
12	22	29-1/8	17-7/8	18	50	26	2	20x25x2
15	24	24-5/8	21-7/8	22	49	25	3	20x25x2
18	28	24-5/8	23-7/8	24	65	34	4	20x25x2
20	32	29-1/8	27-7/8	28	75	39	6	16x25x2
24	39	29-1/8	34-7/8	35	100	51	6	20x25x2
30	44	30-3/8	39-7/8	40	135	-	8	20x25x2
36	52	27-1/8	47-7/8	48	154	-	10	20x25x2
42	58	32-1/8	53-7/8	54	185	-	15	20x25x2

PRESSURE LOSS GUIDE FOR 1" FILTER BOX

Use the estimated pressure drop graphs to help select the proper fan that will deliver the desired airflow. Enter the graph from the bottom at the specified CFM and move vertically upward to the fan curve for the desired size, then horizontally to the left and read the estimated static pressure drop resulting from these typical accessory packages. Add the accessory pressure loss to the system (or building) design static pressure loss to obtain the total static pressure loss to be used for the proper fan selection.

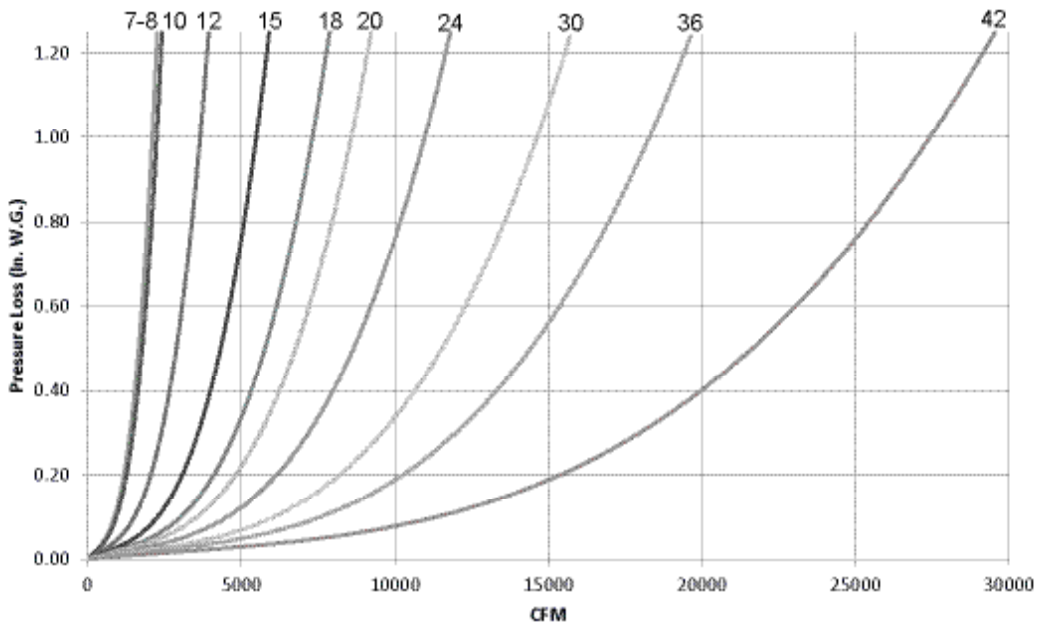

PRESSURE LOSS GUIDE FOR 2" FILTER BOX

Use the estimated pressure drop graphs to help select the proper fan that will deliver the desired airflow. Enter the graph from the bottom at the specified CFM and move vertically upward to the fan curve for the desired size, then horizontally to the left and read the estimated static pressure drop resulting from these typical accessory packages. Add the accessory pressure loss to the system (or building) design static pressure loss to obtain the total static pressure loss to be used for the proper fan selection.

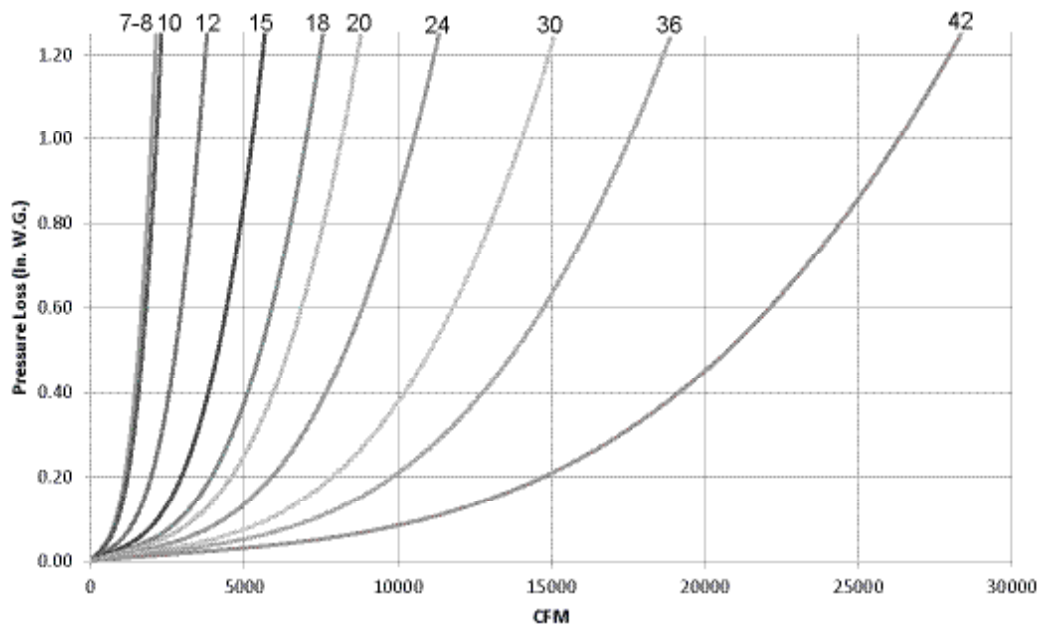

SIDE DISCHARGE OPTION

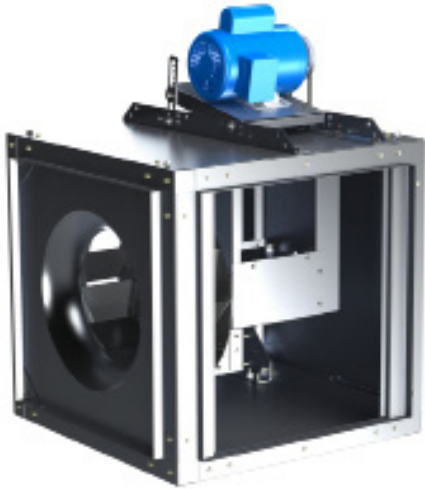

Dimensions (in.)

MODEL	A(IN)	B(IN)	C(IN)	D(IN)
SQB 7	11-7/8	11-7/8	23	15
SQB 8	11-7/8	11-7/8	23	15
SQB 10	13-7/8	13-7/8	23	17
SQB 12	17-7/8	17-7/8	23	21
SQB 15	21-7/8	21-7/8	30	24
SQB 15 HP	21-7/8	21-7/8	30	24
SQB 18	23-7/8	23-7/8	30	28
SQB 18 HP	23-7/8	23-7/8	30	28
SQB 20	27-7/8	27-7/8	34	32
SQB 20 HP	27-7/8	23-7/8	34	32
SQB 24	34-7/8	34-7/8	38	39
SQB 24 HP	34-7/8	34-7/8	38	39
SQB 30	39-7/8	39-7/8	40	44
SQB 30 HP	39-7/8	39-7/8	40	44
SQB 36	47-7/8	NA	45	52
SQB 36 HP	47-7/8	NA	45	52
SQB 42	53-7/8	NA	53	58

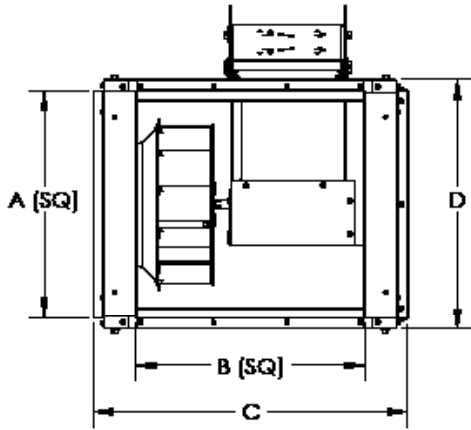

Side Discharge Directions

SIDE DISCHARGE LEFT

SIDE DISCHARGE RIGHT

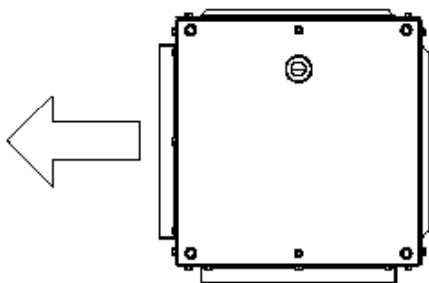

AIRFLOW

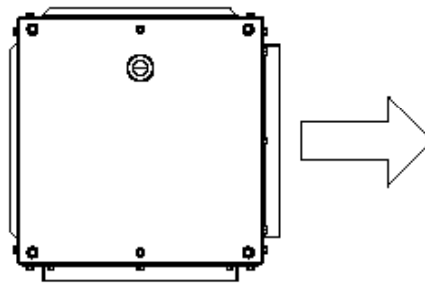

AIRFLOW



PERFORMANCE/DIMENSIONS

SQB 7

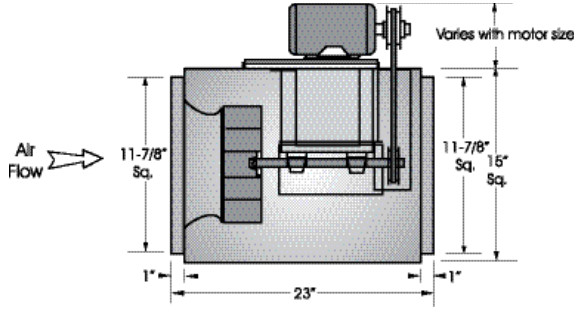

Outlet Velocity = CFM x 1.02
 Tip Speed = RPM x 2.6835
 Maximum Motor Frame Size = 145T
 Maximum RPM = 2430
 Maximum BHP at a Given RPM = (RPM/3022)³

Unit Specifications
 Housing Metal Thickness = 18 GA.
 Approximate Weight = 75 lbs.

CFM / BHP @ Static Pressure / Sones										Drive Range	RPM	HP	Tip Speed		
1/8	1/4	3/8	1/2	5/8	3/4	1	1-1/4	1-1/2	1-3/4						
151	98	-	-	-	-	-	-	-	-	DPI	1070	1/4	2871		
.04/4.4	.04/4.4	-	-	-	-	-	-	-	-		1150	1/4	3086		
169	122	-	-	-	-	-	-	-	-		1210	1/4	3247		
.06/5.5	.06/5.4	-	-	-	-	-	-	-	-		1290	1/4	3462		
182	138	86	-	-	-	-	-	-	-		1370	1/4	3676		
.06/6.2	.06/6.1	.06/6.1	-	-	-	-	-	-	-		1450	1/4	3891		
199	159	113	-	-	-	-	-	-	-		1530	1/4	4106		
.08/7.1	.08/7.0	.08/7.0	-	-	-	-	-	-	-		1610	1/4	4320		
216	179	138	89	-	-	-	-	-	-		1690	1/4	4535		
.09/7.9	.09/7.7	.09/7.7	.09/7.7	-	-	-	-	-	-		1730	1/4	4642		
233	199	161	118	.11/8.4	-	-	-	-	-	DPI	1770	1/4	4750		
.11/8.6	.11/8.5	.11/8.4	.11/8.4	.11/8.4	-	-	-	-	-		1810	1/4	4857		
249	217	182	144	.13/9.1	99	.12/9.1	-	-	-		1850	1/4	4964		
.13/9.4	.13/9.2	.13/9.1	.13/9.1	.13/9.1	128	.15/9.9	-	-	-		1890	1/4	5072		
265	235	203	167	128	.15/9.9	-	-	-	-		DPI	1930	1/4	5179	
.15/10.2	.15/10.1	.15/9.9	.15/9.9	.15/9.9	-	-	-	-	-			1970	1/3	5286	
281	253	223	190	154	114	-	-	-	-			2050	1/3	5501	
.18/11.2	.18/11.0	.18/10.8	.18/10.8	.17/10.8	.17/10.8	-	-	-	-			2110	1/3	5662	
289	262	232	201	167	129	-	-	-	-			DPI	2190	1/2	5877
.19/11.8	.19/11.7	.19/11.4	.19/11.3	.19/11.3	.18/11.3	-	-	-	-				2270	1/2	6091
297	270	242	211	178	143	-	-	-	-	2350			1/2	6306	
.20/12.4	.20/12.3	.20/12.0	.20/11.9	.20/11.9	.20/11.9	-	-	-	-	2430			1/2	6521	
304	279	251	222	190	156	-	-	-	-	DPI			-	-	-
.22/13.0	.22/12.9	.22/12.6	.22/12.4	.22/12.4	.21/12.4	-	-	-	-				-	-	-
312	287	260	232	201	169	-	-	-	-		-		-	-	-
.23/13.6	.23/13.5	.23/13.2	.23/12.9	.23/12.9	.23/12.9	-	-	-	-		-		-	-	-
320	296	270	242	212	181	105	-	-	-		-		-	-	-
.25/14.2	.25/14.2	.25/13.9	.25/13.6	.25/13.5	.24/13.5	.22/13.5	-	-	-		-		-	-	-
328	304	279	252	223	193	123	-	-	-		-	-	-	-	
.26/14.9	.26/14.8	.26/14.5	.26/14.3	.26/14.2	.26/14.2	.24/14.2	-	-	-		-	-	-	-	
335	312	288	261	234	205	138	-	-	-		-	-	-	-	
.28/15.5	.28/15.5	.28/15.2	.28/14.9	.28/14.8	.28/14.8	.26/14.8	-	-	-		-	-	-	-	
351	329	305	281	254	227	167	-	-	-	-	-	-	-		
.32/16.8	.31/16.7	.31/16.6	.31/16.3	.31/16.1	.31/16.1	.31/16.1	-	-	-	-	-	-	-		
362	341	319	295	270	243	186	116	-	-	-	-	-	-		
.34/17.8	.34/17.7	.34/17.6	.34/17.3	.34/17.1	.34/17.0	.34/17.0	.31/17.0	-	-	-	-	-	-		
377	357	336	313	289	264	211	150	-	-	-	-	-	-		
.39/19.1	.38/19.0	.38/18.9	.38/18.7	.38/18.5	.38/18.3	.38/18.3	.36/18.3	-	-	-	-	-	-		
393	373	353	331	.42/20	309	285	235	179	107	-	-	-	-		
.43/20	.43/20	.42/20	.42/20	.43/19.9	.43/19.9	.43/19.7	.43/19.7	.41/19.7	.38/19.7	-	-	-	-		
408	389	370	349	327	.47/21	305	257	206	145	-	-	-	-		
.48/22	.47/22	.47/22	.47/22	.47/22	.47/21	.47/21	.47/21	.46/21	.44/21	-	-	-	-		
423	405	386	366	346	324	279	231	176	102	-	-	-	-		
.53/24	.52/24	.52/24	.52/23	.52/23	.52/23	.52/23	.52/23	.50/23	.46/23	-	-	-	-		

Performance certified is for installation type B - free inlet, ducted outlet.
 Power Ratings (BHP) does not include drive losses.
 Performance ratings do not include the effects of appurtenances in the airstream.

The sound ratings shown are loudness values in fan sones @ 5' (1.5m) in a hemispherical free field calculated per AMCA Standard 301. Values shown are for installation type A - free inlet fan sone levels.



S&P USA Ventilation Systems, LLC., Div. of Soler & Palau Ventilation Group, certifies that the Models SQB shown herein are licensed to bear the AMCA Seal. The ratings shown are based on test and procedures performed in accordance with AMCA Publication 211 and AMCA Publication 311 and comply with the requirement of the AMCA Certified Ratings Program.

SQB 8

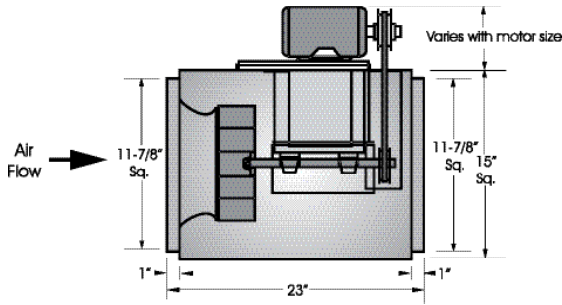

Outlet Velocity = CFM x 1.02
 Tip Speed = RPM x 2.6835
 Maximum Motor Frame Size = 145T
 Maximum RPM = 2625
 Maximum BHP at a Given RPM = $(RPM/2876)^3$

Unit Specifications
 Housing Metal Thickness = 18 GA.
 Approximate Weight = 75 lbs.

CFM / BHP @ Static Pressure / Sones										Drive Range	RPM	HP	Tip Speed		
1/8	1/4	3/8	1/2	5/8	3/4	1	1-1/4	1-1/2	1-3/4						
453	347	-	-	-	-	-	-	-	-	DP5	1050	1/4	2818		
.05/5.0	.05/4.8	-	-	-	-	-	-	-	-		1125	1/4	3019		
542	460	336	-	-	-	-	-	-	-		1200	1/4	3220		
.07/7.0	.08/6.8	.07/6.8	-	-	-	-	-	-	-		1275	1/4	3421		
585	510	415	-	-	-	-	-	-	-		1350	1/4	3623		
.09/8.0	.09/7.8	.09/7.8	-	-	-	-	-	-	-		1425	1/4	3824		
627	558	477	331	-	-	-	-	-	-		1500	1/4	4025		
.10/8.7	.11/8.5	.11/8.4	.10/8.6	-	-	-	-	-	-		1575	1/4	4226		
669	604	532	434	-	-	-	-	-	-		1650	1/4	4428		
.12/9.5	.12/9.4	.13/9.2	.13/9.3	-	-	-	-	-	-		1725	1/4	4629		
711	650	584	503	346	-	-	-	-	-	DP6	1800	1/4	4830		
.14/10.2	.14/10.1	.15/10.0	.15/9.9	.14/10.0	-	-	-	-	-		1850	1/3	4964		
753	695	633	563	465	-	-	-	-	-		1900	1/3	5099		
.16/11.1	.16/10.9	.17/10.8	.17/10.7	.17/10.8	-	-	-	-	-		1950	1/3	5233		
794	738	681	618	539	397	-	-	-	-		2025	1/3	5434		
.18/12.0	.19/11.9	.19/11.7	.20/11.6	.20/11.7	.18/12.0	-	-	-	-		2075	1/2	5568		
835	782	728	669	602	509	-	-	-	-		2125	1/2	5702		
.21/13.1	.21/13.0	.22/12.8	.22/12.7	.23/12.6	.22/12.9	-	-	-	-		2175	1/2	5836		
876	825	774	719	658	584	-	-	-	-		2275	1/2	6105		
.24/14.3	.24/14.1	.25/13.9	.25/13.8	.26/13.7	.26/13.8	-	-	-	-		2325	1/2	6239		
903	853	804	752	694	627	-	-	-	-	DP7	2475	3/4	6642		
.26/15.0	.26/14.9	.27/14.7	.27/14.6	.28/14.4	.28/14.4	-	-	-	-		2625	3/4	7044		
930	882	833	783	729	667	445	-	-	-						
.28/15.8	.28/15.7	.29/15.5	.30/15.4	.30/15.2	.30/15.1	.28/15.6	-	-	-						
957	910	863	815	763	705	536	-	-	-						
.30/16.6	.31/16.5	.31/16.3	.32/16.2	.32/16.1	.33/15.9	.32/16.3	-	-	-						
998	952	907	861	812	759	623	-	-	-						
.34/17.8	.34/17.7	.35/17.6	.35/17.4	.36/17.3	.36/17.2	.36/17.3	-	-	-						
1024	980	936	891	844	794	671	-	-	-		DP8				
.37/18.7	.37/18.5	.37/18.4	.38/18.3	.39/18.1	.39/18.0	.39/18.0	-	-	-						
1051	1008	965	921	876	828	715	500	-	-						
.39/19.5	.40/19.4	.40/19.3	.41/19.1	.41/19.1	.42/18.9	.42/18.8	.39/19.2	-	-						
1078	1036	993	951	907	861	755	592	-	-						
.42/20	.42/20	.43/20	.44/19.9	.44/19.9	.45/19.8	.45/19.6	.44/20	-	-						
1132	1091	1051	1010	969	926	831	708	-	-						
.48/22	.48/22	.49/22	.50/22	.50/22	.51/22	.52/21	.52/22	-	-						
1158	1118	1079	1039	999	958	868	755	540	-						
.51/24	.52/23	.52/23	.53/23	.53/23	.54/23	.55/23	.55/23	.51/23	-						
1238	1200	1163	1126	1089	1051	971	878	758	-						
.62/27	.62/27	.63/27	.63/27	.64/27	.65/27	.66/26	.67/26	.66/26	-						
1318	1282	1247	1212	1177	1142	1068	988	894	766						
.74/30	.74/30	.75/30	.75/29	.76/29	.77/29	.78/29	.79/29	.80/29	.79/29						

Performance certified is for installation type B - free inlet, ducted outlet.
 Power Ratings (BHP) does not include drive losses.
 Performance ratings do not include the effects of appurtenances in the airstream.

The sound ratings shown are loudness values in fan sones @ 5' (1.5m) in a hemispherical free field calculated per AMCA Standard 301. Values shown are for installation type A - free inlet fan sone levels.



S&P USA Ventilation Systems, LLC., Div. of Soler & Palau Ventilation Group, certifies that the Models SQB shown herein are licensed to bear the AMCA Seal. The ratings shown are based on test and procedures performed in accordance with AMCA Publication 211 and AMCA Publication 311 and comply with the requirement of the AMCA Certified Ratings Program.



STANDARD 705



SQB 10

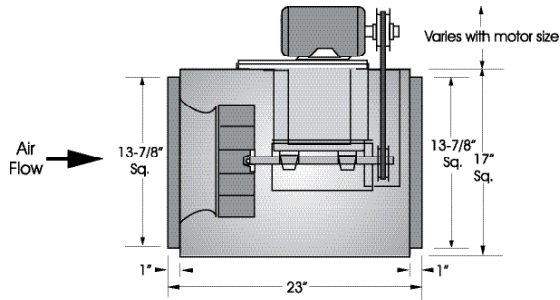

Outlet Velocity = CFM x 0.74
 Tip Speed = RPM x 3.207
 Maximum Motor Frame Size = 145T
 Maximum RPM = 2400
 Maximum BHP at a Given RPM = $(RPM/2376)^3$

Unit Specifications

Housing Metal Thickness = 18 GA.
 Approximate Weight = 85 lbs.

CFM / BHP @ Static Pressure / Sones											Drive Range	RPM	HP	Tip Speed			
1/8	1/4	3/8	1/2	5/8	3/4	1	1-1/4	1-1/2	1-3/4	2							
.798	.687	.540	-	-	-	-	-	-	-	-	DP 10	1050	1/4	3367			
.09/5.5	.09/5.2	.09/5.1	-	-	-	-	-	-	-	-		1100	1/4	3528			
.917	.821	.712	.557	-	-	-	-	-	-	-		1175	1/4	3768			
.12/7.2	.12/6.8	.12/6.6	.12/6.6	-	-	-	-	-	-	-		1250	1/4	4009			
.988	.897	.800	.681	.436	-	-	-	-	-	-		1300	1/4	4169			
.14/8.3	.15/7.9	.15/7.5	.15/7.5	.12/7.5	-	-	-	-	-	-		1350	1/4	4330			
1035	948	856	750	594	-	-	-	-	-	-		DP 11	1400	1/4	4490		
.16/8.8	.17/8.4	.17/8.0	.17/8.0	.16/8.0	-	-	-	-	-	-			1450	1/4	4650		
1081	997	911	814	688	-	-	-	-	-	-			1500	1/4	4811		
.18/9.4	.18/8.9	.19/8.6	.19/8.4	.18/8.4	-	-	-	-	-	-			1550	1/3	4971		
1127	1046	964	874	765	593	-	-	-	-	-	DP 12		1600	1/3	5131		
.20/10.0	.21/9.5	.21/9.1	.21/8.9	.21/8.9	.19/8.9	-	-	-	-	-			1650	1/3	5292		
1173	1095	1016	932	834	702	-	-	-	-	-			1700	1/2	5452		
.22/10.5	.23/10.2	.23/9.7	.23/9.4	.23/9.4	.22/9.4	-	-	-	-	-			1775	1/2	5692		
1219	1143	1068	988	898	787	-	-	-	-	-			DP 13	1850	1/2	5933	
.25/11.1	.25/10.7	.26/10.4	.26/10.0	.26/9.9	.25/9.9	-	-	-	-	-				1900	1/2	6093	
1265	1191	1118	1042	959	861	-	-	-	-	-		DP 14		1950	3/4	6254	
.27/11.7	.28/11.3	.28/10.9	.28/10.6	.29/10.4	.28/10.4	-	-	-	-	-				2025	3/4	6494	
1310	1239	1169	1096	1018	929	634	-	-	-	-				2100	3/4	6735	
.30/12.4	.30/12.0	.31/11.6	.31/11.2	.31/11.0	.31/11.0	.27/10.9	-	-	-	-				2175	3/4	6975	
1356	1286	1216	1148	1074	992	763	-	-	-	-	DP 14			2250	1	7216	
.33/13.1	.33/12.7	.34/12.3	.34/11.9	.34/11.6	.34/11.5	.32/11.5	-	-	-	-				2400	1	7697	
1401	1334	1267	1200	1130	1053	857	-	-	-	-							
.36/13.9	.36/13.5	.37/13.1	.37/12.7	.38/12.4	.38/12.3	.36/12.1	-	-	-	-							
1469	1404	1340	1276	1210	1140	973	654	-	-	-							
.41/14.9	.41/14.6	.42/14.3	.42/13.9	.43/13.6	.43/13.3	.42/13.3	.36/13.2	-	-	-							
1536	1474	1413	1352	1289	1224	1076	864	-	-	-							
.46/16.2	.47/15.8	.47/15.5	.48/15.1	.48/14.8	.48/14.5	.48/14.4	.46/14.3	-	-	-							
1581	1520	1461	1401	1341	1278	1139	957	-	-	-							
.50/17.0	.50/16.7	.51/16.3	.51/16.0	.52/15.7	.52/15.3	.53/15.1	.51/15.1	-	-	-							
1626	1566	1508	1451	1392	1332	1200	1037	741	-	-							
.54/17.9	.54/17.5	.55/17.2	.56/16.9	.56/16.5	.57/16.2	.57/15.9	.56/15.9	.49/15.9	-	-							
1693	1636	1579	1524	1468	1411	1288	1145	943	-	-							
.60/19.2	.61/18.8	.61/18.5	.62/18.2	.63/17.9	.63/17.6	.64/17.1	.63/17.1	.60/17.1	-	-							
1760	1704	1650	1597	1543	1488	1373	1243	1079	773	-							
.67/21	.68/20	.68/19.9	.69/19.6	.70/19.3	.70/19.0	.71/18.4	.71/18.3	.69/18.2	.60/18.3	-							
1827	1773	1720	1669	1617	1564	1456	1336	1194	993	-							
.75/22	.75/22	.76/21	.76/21	.77/21	.78/20	.79/19.8	.79/19.5	.78/19.5	.74/19.4	-							
1894	1841	1790	1740	1690	1640	1536	1424	1297	1135	849							
.83/24	.83/23	.84/23	.84/23	.85/22	.86/22	.87/21	.87/21	.87/21	.85/21	.74/21							
2027	1977	1929	1882	1835	1788	1693	1593	1484	1360	1205							
1.00/27	1.01/27	1.01/26	1.02/26	1.03/26	1.03/25	1.05/25	1.06/24	1.06/24	1.06/24	1.03/24							

Performance certified is for installation type B - free inlet, ducted outlet.
 Power Ratings (BHP) does not include drive losses.
 Performance ratings do not include the effects of appurtenances in the airstream.

The sound ratings shown are loudness values in fan sones @ 5' (1.5m) in a hemispherical free field calculated per AMCA Standard 301. Values shown are for installation type A - free inlet fan sone levels.



S&P USA Ventilation Systems, LLC., Div. of Soler & Palau Ventilation Group, certifies that the Models SQB shown herein are licensed to bear the AMCA Seal. The ratings shown are based on test and procedures performed in accordance with AMCA Publication 211 and AMCA Publication 311 and comply with the requirement of the AMCA Certified Ratings Program.





SQB 12

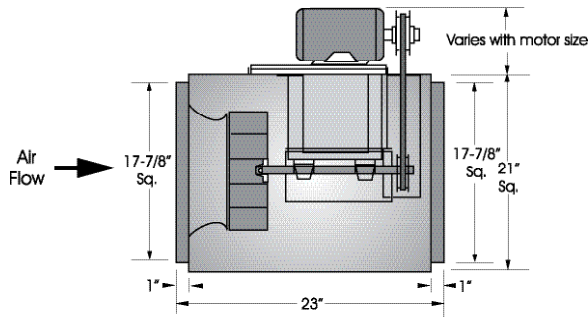

Outlet Velocity = CFM x 0.45
 Tip Speed = RPM x 3.534
 Maximum Motor Frame Size = 145T
 Maximum RPM = 2125
 Maximum BHP at a Given RPM = (RPM/1821)³

Unit Specifications
 Housing Metal Thickness = 18 GA.
 Approximate Weight = 95 lbs.

CFM / BHP @ Static Pressure / Sones											Drive Range	RPM	HP	Tip Speed
1/8	1/4	3/8	1/2	5/8	3/4	1	1-1/4	1-1/2	1-3/4	2				
1293	1098	769	-	-	-	-	-	-	-	-	DP 15	900	1/4	3181
.12/5.9	.12/5.6	.11/5.4	-	-	-	-	-	-	-	-				
1474	1309	1102	-	-	-	-	-	-	-	-	DP 16	1000	1/4	3534
.16/7.3	.16/7.0	.16/6.8	-	-	-	-	-	-	-	-				
1518	1359	1165	806	-	-	-	-	-	-	-	DP 17	1025	1/4	3623
.17/7.6	.18/7.4	.18/7.1	.15/6.9	-	-	-	-	-	-	-				
1607	1458	1284	1036	-	-	-	-	-	-	-	DP 18	1075	1/4	3799
.20/8.4	.20/8.1	.21/7.9	.20/7.7	-	-	-	-	-	-	-				
1686	1544	1384	1177	-	-	-	-	-	-	-	DP 19	1120	1/4	3958
.22/9.1	.23/8.9	.23/8.6	.23/8.4	-	-	-	-	-	-	-				
1773	1639	1491	1312	1032	-	-	-	-	-	-	DP 20	1170	1/4	4135
.25/10.0	.26/9.7	.26/9.4	.26/9.3	.24/9.1	-	-	-	-	-	-				
1868	1741	1604	1445	1235	-	-	-	-	-	-	DP 15	1225	1/3	4330
.29/11.0	.30/10.8	.30/10.5	.30/10.3	.30/10.1	-	-	-	-	-	-				
1954	1833	1704	1558	1380	1099	-	-	-	-	-	DP 16	1275	1/3	4506
.33/12.0	.33/11.8	.34/11.5	.34/11.3	.34/11.1	.31/10.9	-	-	-	-	-				
2040	1924	1801	1667	1509	1297	-	-	-	-	-	DP 17	1325	1/2	4683
.37/13.1	.37/12.8	.38/12.5	.39/12.3	.38/12.1	.37/11.9	-	-	-	-	-				
2168	2059	1945	1822	1685	1520	-	-	-	-	-	DP 18	1400	1/2	4948
.43/14.6	.44/14.3	.45/14.1	.45/13.8	.45/13.7	.45/13.5	-	-	-	-	-				
2296	2192	2085	1973	1850	1710	1282	-	-	-	-	DP 19	1475	1/2	5213
.51/15.8	.51/15.5	.52/15.3	.53/15.1	.53/14.9	.53/14.7	.48/14.5	-	-	-	-				
2380	2280	2178	2070	1955	1827	1481	-	-	-	-	DP 20	1525	3/4	5390
.56/16.6	.57/16.3	.57/16.1	.58/15.9	.59/15.7	.59/15.6	.56/15.3	-	-	-	-				
2465	2368	2269	2167	2057	1938	1639	-	-	-	-	DP 15	1575	3/4	5567
.62/17.3	.62/17.1	.63/16.9	.64/16.7	.64/16.5	.65/16.4	.63/16.1	-	-	-	-				
2549	2456	2360	2262	2158	2046	1778	1303	-	-	-	DP 16	1625	3/4	5743
.68/18.2	.68/18.0	.69/17.8	.70/17.6	.71/17.4	.71/17.2	.70/17.0	.62/16.7	-	-	-				
2633	2543	2450	2356	2256	2151	1906	1545	-	-	-	DP 17	1675	3/4	5920
.74/19.0	.75/18.8	.76/18.6	.76/18.4	.77/18.2	.78/18.0	.78/17.8	.73/17.6	-	-	-				
2675	2586	2495	2402	2305	2202	1967	1638	-	-	-	DP 18	1700	1	6008
.77/19.4	.78/19.2	.79/19.0	.80/18.6	.80/18.6	.81/18.5	.81/18.2	.78/18.0	-	-	-				
2759	2672	2585	2495	2402	2304	2084	1800	1111	-	-	DP 19	1750	1	6185
.84/21	.85/20	.86/20	.87/19.9	.88/19.6	.88/19.4	.89/19.1	.87/18.9	.66/18.7	-	-				
2843	2758	2673	2586	2497	2403	2197	1943	1539	-	-	DP 20	1800	1	6362
.92/22	.93/21	.93/21	.94/21	.95/21	.96/21	.97/20	.95/19.7	.87/19.5	-	-				
2926	2844	2762	2678	2591	2501	2306	2074	1751	-	-	DP 15	1850	1	6538
1.00/23	1.00/22	1.01/22	1.02/22	1.03/22	1.04/22	1.05/21	1.04/21	.99/20	-	-				
3010	2930	2850	2768	2684	2598	2412	2197	1920	1356	-	DP 16	1900	1-1/2	6715
1.08/24	1.09/24	1.09/23	1.10/23	1.11/23	1.12/23	1.13/22	1.13/22	1.10/22	.91/21	-				
3176	3101	3024	2947	2869	2788	2618	2428	2203	1897	-	DP 17	2000	1-1/2	7069
1.26/26	1.27/26	1.27/26	1.28/26	1.29/25	1.30/25	1.32/25	1.33/24	1.32/24	1.26/24	-				
3384	3313	3241	3169	3096	3022	2866	2699	2510	2286	1979	DP 18	2125	1-1/2	7510
1.51/29	1.52/29	1.52/29	1.53/29	1.54/29	1.55/28	1.57/28	1.59/28	1.59/27	1.57/27	1.50/26				

Performance certified is for installation type B - free inlet, ducted outlet.
 Power Ratings (BHP) does not include drive losses.
 Performance ratings do not include the effects of appurtenances in the airstream.

The sound ratings shown are loudness values in fan sones @ 5' (1.5m) in a hemispherical free field calculated per AMCA Standard 301. Values shown are for installation type A - free inlet fan sone levels.



S&P USA Ventilation Systems, LLC., Div. of Soler & Palau Ventilation Group, certifies that the Models SQB shown herein are licensed to bear the AMCA Seal. The ratings shown are based on test and procedures performed in accordance with AMCA Publication 211 and AMCA Publication 311 and comply with the requirement of the AMCA Certified Ratings Program.



SQB 15

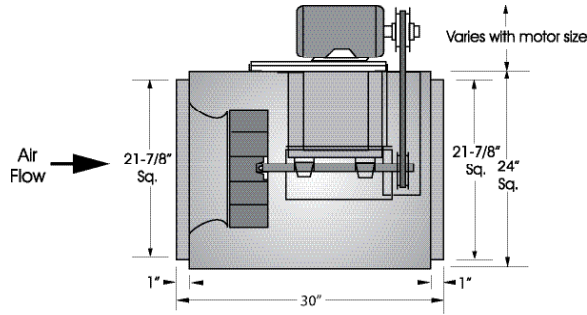

Outlet Velocity = CFM x 0.30
 Tip Speed = RPM x 4.058
 Maximum Motor Frame Size = 184T
 Maximum RPM = 1910
 Maximum BHP at a Given RPM = $(RPM/1492)^3$

Unit Specifications
 Housing Metal Thickness = 18 GA.
 Approximate Weight = 140 lbs.

CFM / BHP @ Static Pressure / Sones												Drive Range	RPM	HP	Tip Speed
1/8	1/4	3/8	1/2	5/8	3/4	1	1-1/4	1-1/2	1-3/4	2	2-1/4				
1611	1408	1135	-	-	-	-	-	-	-	-	-	DP 21	770	1/4	3126
.13/6.4	.14/5.8	.14/5.0	-	-	-	-	-	-	-	-	-				
1753	1567	1349	-	-	-	-	-	-	-	-	-				
.16/7.3	.16/6.8	.17/6.1	-	-	-	-	-	-	-	-	-	DP 22	825	1/4	3348
1894	1721	1531	1269	-	-	-	-	-	-	-	-				
.19/8.3	.20/7.7	.20/7.1	.20/6.3	-	-	-	-	-	-	-	-				
2071	1911	1745	1548	1227	-	-	-	-	-	-	-	DP 23	880	1/4	3571
.23/9.6	.24/9.0	.25/8.4	.26/7.7	.24/7.0	-	-	-	-	-	-	-				
2172	2018	1861	1684	1447	-	-	-	-	-	-	-				
.26/10.3	.27/9.7	.29/9.2	.29/8.6	.29/7.8	-	-	-	-	-	-	-				
2347	2203	2058	1904	1723	1464	-	-	-	-	-	-	DP 25	990	1/3	4017
.32/11.7	.33/11.1	.35/10.6	.36/10.2	.36/9.4	.35/8.7	-	-	-	-	-	-				
2459	2320	2182	2038	1877	1674	-	-	-	-	-	-				
.36/12.6	.38/12.1	.39/11.6	.40/11.1	.41/10.5	.40/9.7	-	-	-	-	-	-				
2595	2462	2331	2197	2052	1884	-	-	-	-	-	-	DP 27	1105	1/2	4484
.42/13.7	.43/13.3	.45/12.9	.46/12.4	.47/12.0	.47/11.1	-	-	-	-	-	-				
2707	2577	2452	2324	2189	2038	1576	-	-	-	-	-				
.47/14.9	.48/14.3	.50/13.9	.51/13.5	.52/13.1	.53/12.4	.49/10.8	-	-	-	-	-				
2842	2718	2597	2476	2350	2214	1865	-	-	-	-	-	DP 29	1205	1/2	4890
.54/16.0	.55/15.6	.56/15.1	.58/14.6	.59/14.2	.60/13.7	.59/12.2	-	-	-	-	-				
3026	2908	2794	2680	2564	2442	2159	1668	-	-	-	-				
.64/17.7	.65/17.2	.66/16.7	.68/16.3	.69/15.9	.71/15.4	.72/14.1	.66/12.7	-	-	-	-				
3124	3009	2897	2787	2675	2559	2298	1925	-	-	-	-	DP 31	1335	3/4	5417
.70/18.5	.71/18.1	.72/17.6	.74/17.2	.75/16.8	.77/16.4	.78/15.1	.76/13.8	-	-	-	-				
3295	3184	3078	2973	2868	2760	2526	2236	1585	-	-	-				
.81/20	.82/19.6	.83/19.2	.85/18.8	.87/18.4	.88/18.0	.90/17.1	.91/15.6	.76/14.3	-	-	-				
3502	3396	3295	3196	3097	2996	2786	2545	2225	-	-	-	DP 33	1445	1	5864
.96/22	.97/22	.98/21	1.00/21	1.02/20	1.03/19.9	1.06/19.2	1.08/18.0	1.06/16.7	-	-	-				
3575	3471	3371	3274	3177	3079	2874	2645	2356	1672	-	-				
1.01/23	1.03/22	1.04/22	1.06/21	1.08/21	1.09/21	1.12/19.9	1.14/18.8	1.13/17.5	.93/16.2	-	-				
3732	3632	3536	3442	3349	3255	3063	2853	2608	2268	-	-	DP 35	1560	1-1/2	6330
1.14/24	1.16/24	1.17/24	1.19/23	1.21/23	1.23/22	1.26/21	1.29/21	1.29/19.3	1.25/18.1	-	-				
3854	3756	3662	3570	3480	3390	3205	3007	2784	2503	1963	-				
1.25/26	1.27/25	1.28/25	1.30/24	1.32/24	1.34/24	1.37/23	1.40/22	1.42/21	1.40/19.5	1.24/18.4	-				
3999	3904	3813	3724	3636	3549	3372	3187	2983	2742	2413	-	DP 37	1675	1-1/2	6797
1.39/27	1.40/27	1.42/26	1.44/26	1.46/25	1.48/25	1.51/24	1.55/24	1.57/22	1.57/21	1.52/20	-				
4023	3928	3838	3749	3662	3576	3400	3216	3015	2780	2465	-				
1.42/27	1.43/27	1.44/26	1.46/26	1.48/26	1.50/25	1.54/25	1.57/24	1.60/23	1.60/22	1.56/20	-				
4119	4027	3938	3851	3766	3681	3510	3333	3141	2923	2651	2181	DP 39	1745	2	7081
1.52/28	1.53/28	1.54/28	1.56/27	1.58/27	1.60/26	1.64/26	1.68/25	1.70/24	1.71/23	1.69/22	1.54/20				
4252	4162	4075	3991	3908	3826	3660	3490	3310	3110	2876	2558				
1.66/30	1.67/29	1.69/29	1.71/29	1.73/28	1.75/28	1.79/27	1.82/26	1.86/26	1.88/24	1.87/23	1.81/22				
4421	4333	4249	4168	4087	4008	3849	3688	3518	3336	3131	2884	DP 41	1840	2	7467
1.85/32	1.87/31	1.88/31	1.90/31	1.92/30	1.94/30	1.98/29	2.03/28	2.06/27	2.09/27	2.10/25	2.08/24				

Performance certified is for installation type B - free inlet, ducted outlet.
 Power Ratings (BHP) does not include drive losses.
 Performance ratings do not include the effects of appurtenances in the airstream.

The sound ratings shown are loudness values in fan sones @ 5' (1.5m) in a hemispherical free field calculated per AMCA Standard 301. Values shown are for installation type A - free inlet fan sone levels.



S&P USA Ventilation Systems, LLC., Div. of Soler & Palou Ventilation Group, certifies that the Models SQB shown herein are licensed to bear the AMCA Seal. The ratings shown are based on test and procedures performed in accordance with AMCA Publication 211 and AMCA Publication 311 and comply with the requirement of the AMCA Certified Ratings Program.





SQBHP 15

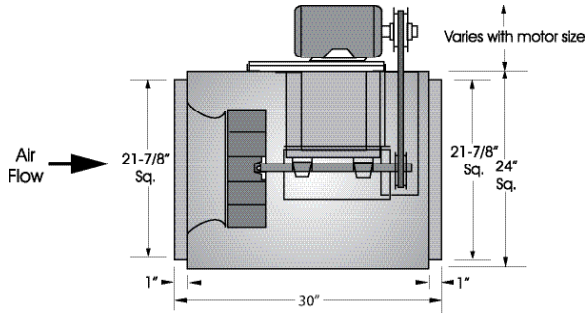

Outlet Velocity = CFM x 0.30
 Tip Speed = RPM x 4.058
 Maximum Motor Frame Size = 184T
 Maximum RPM = 2130
 Maximum BHP at a Given RPM = (RPM/1708)³

Unit Specifications
 Housing Metal Thickness = 18 GA.
 Approximate Weight = 140 lbs.

CFM / BHP @ Static Pressure / Sones												Drive Range	RPM	HP	Tip Speed
3/4	1	1-1/4	1-1/2	1-3/4	2	2-1/4	2-1/2	2-3/4	3	3-1/4	3-1/2				
1313	741	-	-	-	-	-	-	-	-	-	-	DP 28	1140	1/3	4626
.31/12.6	.26/11.8	-	-	-	-	-	-	-	-	-	-				
1432	1002	-	-	-	-	-	-	-	-	-	-	DP 29	1180	1/3	4788
.35/13.8	.32/13.1	-	-	-	-	-	-	-	-	-	-				
1850	1588	1220	-	-	-	-	-	-	-	-	-	DP 30	1340	1/2	5438
.51/18.2	.51/17.5	.48/16.8	-	-	-	-	-	-	-	-	-				
1910	1660	1326	-	-	-	-	-	-	-	-	-	DP 31	1365	1/2	5539
.53/18.8	.54/18.0	.52/17.4	-	-	-	-	-	-	-	-	-				
1969	1731	1422	847	-	-	-	-	-	-	-	-	DP 32	1390	3/4	5640
.56/19.4	.57/18.6	.55/17.9	.46/17.4	-	-	-	-	-	-	-	-				
2086	1865	1595	1200	-	-	-	-	-	-	-	-	DP 33	1440	3/4	5843
.62/21	.63/19.8	.62/19.1	.58/18.4	-	-	-	-	-	-	-	-				
2200	1994	1751	1431	-	-	-	-	-	-	-	-	DP 31	1490	3/4	6046
.69/22	.70/21	.70/20	.67/19.6	-	-	-	-	-	-	-	-				
2312	2118	1896	1621	1210	-	-	-	-	-	-	-	DP 32	1540	3/4	6249
.75/24	.77/23	.77/21	.76/21	.69/20	-	-	-	-	-	-	-				
2421	2239	2033	1788	1464	-	-	-	-	-	-	-	DP 33	1590	1	6452
.83/26	.84/24	.85/23	.84/22	.80/21	-	-	-	-	-	-	-				
2530	2356	2163	1941	1666	1255	-	-	-	-	-	-	DP 33	1640	1	6655
.90/27	.92/26	.93/25	.93/23	.90/23	.82/22	-	-	-	-	-	-				
2637	2471	2290	2085	1842	1521	-	-	-	-	-	-	DP 33	1690	1	6858
.98/29	1.00/28	1.02/27	1.02/25	1.01/24	.95/23	-	-	-	-	-	-				
2690	2528	2352	2154	1924	1630	1155	-	-	-	-	-	DP 33	1715	1	6959
1.02/30	1.05/29	1.06/28	1.07/26	1.06/25	1.02/24	.89/23	-	-	-	-	-				
2742	2584	2412	2222	2002	1730	1334	-	-	-	-	-	DP 33	1740	1-1/2	7061
1.06/30	1.09/31	1.11/29	1.12/27	1.11/26	1.07/24	.98/24	-	-	-	-	-				
2847	2695	2532	2353	2151	1912	1601	1044	-	-	-	-	DP 33	1790	1-1/2	7264
1.15/32	1.18/32	1.20/31	1.21/29	1.21/27	1.19/26	1.13/25	.95/25	-	-	-	-				
2951	2805	2649	2480	2293	2077	1814	1443	-	-	-	-	DP 33	1840	1-1/2	7467
1.25/33	1.28/34	1.30/32	1.32/31	1.32/31	1.31/28	1.27/27	1.17/26	-	-	-	-				
3054	2913	2764	2604	2428	2231	1999	1702	1225	-	-	-	DP 33	1890	1-1/2	7669
1.35/35	1.38/35	1.40/34	1.42/33	1.43/31	1.42/30	1.40/28	1.34/28	1.18/27	-	-	-				
3156	3020	2877	2724	2559	2376	2166	1914	1572	-	-	-	DP 33	1940	1-1/2	7872
1.45/36	1.48/36	1.51/36	1.53/35	1.54/33	1.54/31	1.53/30	1.49/29	1.39/29	-	-	-				
3258	3126	2988	2842	2685	2514	2322	2099	1821	1410	-	-	DP 33	1990	2	8075
1.56/38	1.60/38	1.63/38	1.65/37	1.66/35	1.67/33	1.66/32	1.63/31	1.57/30	1.42/30	-	-				
3359	3231	3098	2958	2809	2647	2469	2267	2028	1716	1179	-	DP 33	2040	2	8278
1.67/39	1.71/39	1.74/40	1.77/39	1.79/37	1.80/35	1.79/34	1.77/33	1.73/32	1.64/32	1.40/31	-				
3459	3336	3207	3072	2929	2776	2610	2424	2211	1952	1596	-	DP 33	2090	2	8481
1.79/41	1.83/41	1.87/41	1.90/41	1.92/39	1.93/38	1.93/36	1.92/35	1.89/34	1.83/34	1.70/33	-				
3499	3377	3250	3117	2977	2827	2664	2485	2280	2036	1715	1131	DP 33	2110	2	8562
1.84/42	1.88/42	1.92/42	1.95/42	1.97/40	1.98/38	1.99/37	1.98/36	1.95/35	1.90/34	1.79/34	1.50/33				
3539	3418	3293	3162	3024	2877	2718	2544	2347	2115	1821	1361	DP 33	2130	2	8643
1.89/43	1.93/42	1.97/43	2.00/43	2.03/41	2.04/39	2.05/38	2.04/37	2.02/36	1.97/35	1.88/34	1.67/34				

Performance certified is for installation type B - free inlet, ducted outlet.
 Power Ratings (BHP) does not include drive losses.
 Performance ratings do not include the effects of appurtenances in the airstream.

The sound ratings shown are loudness values in fan sones @ 5' (1.5m) in a hemispherical free field calculated per AMCA Standard 301. Values shown are for installation type A - free inlet fan sone levels.



S&P USA Ventilation Systems, LLC, Div. of Soler & Palou Ventilation Group, certifies that the Models SQB shown herein are licensed to bear the AMCA Seal. The ratings shown are based on test and procedures performed in accordance with AMCA Publication 211 and AMCA Publication 311 and comply with the requirement of the AMCA Certified Ratings Program.





SQB 18

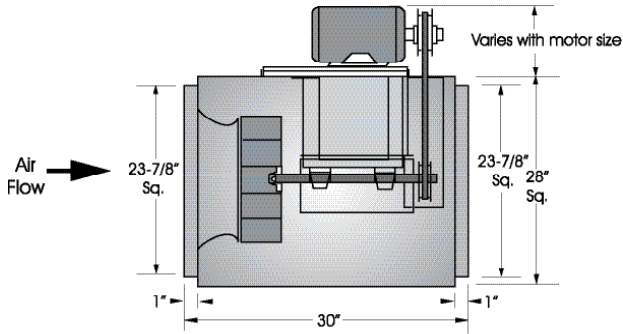

Outlet Velocity = CFM x 0.25
 Tip Speed = RPM x 4.843
 Maximum Motor Frame Size = 184T
 Maximum RPM = 1640
 Maximum BHP at a Given RPM = (RPM/1122)³

Unit Specifications
 Housing Metal Thickness = 18 GA.
 Approximate Weight = 190 lbs.

CFM / BHP @ Static Pressure / Sones											Drive Range	RPM	HP	Tip Speed	
1/8	1/4	3/8	1/2	5/8	3/4	1	1-1/4	1-1/2	1-3/4	2					2-1/4
2434	2167	1849	-	-	-	-	-	-	-	-	-	DP 34	700	1/3	3390
0.25/9.6	0.25/8	0.25/6	-	-	-	-	-	-	-	-	-				
2642	2400	2123	1765	-	-	-	-	-	-	-	-				
0.31/10.4	0.31/9.4	0.31/7.4	0.31/6.2	-	-	-	-	-	-	-	-	DP 35	800	1/3	3875
2847	2626	2376	2087	1509	-	-	-	-	-	-	-				
0.37/11.2	0.38/10.7	0.38/9	0.38/7.4	0.33/6.5	-	-	-	-	-	-	-				
3050	2846	2619	2366	2054	-	-	-	-	-	-	-	DP 36	850	1/2	4117
0.44/12.5	0.45/12.2	0.46/10.6	0.45/9	0.45/7.7	-	-	-	-	-	-	-				
3252	3062	2854	2625	2366	2017	-	-	-	-	-	-				
0.52/14.1	0.54/14.3	0.54/12.3	0.54/10.6	0.54/9.2	0.52/8.1	-	-	-	-	-	-	DP 37	900	1/2	4359
3352	3169	2969	2750	2508	2208	-	-	-	-	-	-				
0.57/14.9	0.58/15.2	0.59/13.4	0.59/11.4	0.58/10.1	0.58/8.9	-	-	-	-	-	-				
3552	3380	3195	2994	2775	2528	-	-	-	-	-	-	DP 38	975	3/4	4722
0.66/16.5	0.68/17	0.69/15.6	0.69/13.6	0.69/11.7	0.68/10.5	-	-	-	-	-	-				
3751	3588	3416	3230	3029	2811	2197	-	-	-	-	-				
0.77/18.1	0.79/18.8	0.8/18	0.8/16	0.8/13.7	0.8/12.2	0.76/10.3	-	-	-	-	-	DP 39	1025	3/4	4964
3850	3692	3525	3345	3152	2946	2416	-	-	-	-	-				
0.82/19.1	0.84/19.7	0.86/19.4	0.86/17.3	0.86/15	0.86/13	0.84/11.1	-	-	-	-	-				
4047	3898	3740	3573	3395	3204	2761	-	-	-	-	-	DP 40	1050	1	5085
0.95/21	0.97/22	0.98/22	0.99/20	0.99/17.8	0.99/15.2	0.98/12.8	-	-	-	-	-				
4146	4000	3847	3685	3513	3329	2913	-	-	-	-	-				
1.01/22	1.03/23	1.05/24	1.06/21	1.06/19.4	1.05/16.6	1.05/13.6	-	-	-	-	-	DP 38	1100	1	5328
4244	4102	3953	3796	3630	3452	3059	-	-	-	-	-				
1.08/23	1.1/23	1.12/24	1.13/22	1.13/20	1.13/17.8	1.12/14.3	1.08/12.8	-	-	-	-				
4441	4305	4164	4016	3860	3695	3335	2891	-	-	-	-	DP 39	1125	1	5449
1.22/24	1.25/24	1.27/25	1.28/24	1.28/22	1.28/20	1.28/15.9	1.26/14.2	-	-	-	-				
4636	4507	4373	4232	4085	3931	3597	3211	2620	-	-	-				
1.38/25	1.4/25	1.43/26	1.44/26	1.45/24	1.45/22	1.45/18	1.43/15.7	1.36/14.2	-	-	-	DP 39	1150	1	5570
4832	4708	4580	4446	4307	4162	3848	3501	3064	-	-	-				
1.55/26	1.58/26	1.6/27	1.62/28	1.63/26	1.63/24	1.63/20	1.62/17.2	1.6/15.7	-	-	-				
4929	4808	4683	4552	4417	4276	3972	3639	3237	-	-	-	DP 39	1200	1-1/2	5812
1.64/26	1.67/27	1.69/28	1.71/28	1.72/27	1.73/25	1.72/22	1.72/18.2	1.7/16.5	-	-	-				
5124	5008	4888	4763	4635	4501	4215	3905	3552	3086	-	-				
1.83/27	1.86/28	1.88/29	1.9/29	1.92/29	1.93/27	1.93/24	1.92/20	1.91/18	1.87/16.7	-	-	DP 39	1250	1-1/2	6054
5319	5207	5091	4972	4850	4723	4453	4161	3841	3459	-	-				
2.03/28	2.06/29	2.09/30	2.11/30	2.13/30	2.14/29	2.15/26	2.14/23	2.14/19.8	2.11/18.2	-	-				
5513	5405	5294	5180	5063	4941	4686	4409	4113	3775	3338	-	DP 40	1300	1-1/2	6296
2.25/30	2.29/30	2.31/31	2.34/31	2.36/32	2.37/31	2.38/28	2.38/25	2.37/22	2.36/19.9	2.31/18.5	-				
5707	5603	5496	5386	5274	5158	4914	4653	4375	4068	3705	3094				
2.49/31	2.52/31	2.55/32	2.58/32	2.6/33	2.62/32	2.63/30	2.63/27	2.63/24	2.62/22	2.59/20	2.42/19	DP 40	1325	2	6417
5997	5898	5797	5694	5588	5479	5252	5010	4752	4479	4174	3809				
2.87/33	2.91/33	2.94/33	2.97/34	2.99/34	3.01/35	3.04/33	3.04/31	3.03/28	3.03/25	3.01/23	2.98/21				
6152	6056	5957	5857	5754	5649	5429	5197	4949	4688	4404	4077	DP 40	1375	2	6660
3.09/34	3.13/35	3.16/35	3.19/35	3.22/36	3.24/36	3.27/34	3.28/32	3.27/30	3.27/27	3.25/25	3.23/23				
6519	6425	6322	6217	6111	6004	5783	5551	5319	5087	4855	4623				
3.47/36	3.51/37	3.54/37	3.57/38	3.6/39	3.63/39	3.66/37	3.68/35	3.67/33	3.66/31	3.64/29	3.62/27	DP 40	1425	2	6902
6997	6902	6807	6709	6611	6512	6291	6059	5827	5595	5363	5131				
4.25/38	4.29/39	4.32/39	4.35/40	4.38/41	4.41/41	4.44/39	4.46/37	4.45/35	4.44/33	4.42/31	4.4/29				
7475	7379	7282	7183	7083	6982	6761	6529	6297	6065	5833	5601	DP 40	1475	3	7144
4.63/40	4.67/41	4.7/41	4.73/42	4.76/43	4.79/43	4.82/41	4.84/39	4.83/37	4.82/35	4.8/33	4.78/31				
7953	7856	7758	7658	7557	7455	7234	7002	6770	6538	6306	6074				
5.01/42	5.05/43	5.08/43	5.11/44	5.14/45	5.17/45	4.95/43	4.92/41	4.91/39	4.9/37	4.88/35	4.86/33	DP 40	1525	3	7386
8431	8333	8234	8133	8031	7928	7707	7475	7243	7011	6779	6547				
5.39/44	5.43/45	5.46/45	5.49/46	5.52/47	5.55/47	5.33/45	5.3/43	5.29/41	5.28/39	5.26/37	5.24/35				
8909	8810	8710	8609	8507	8404	8183	7951	7719	7487	7255	7023	DP 40	1600	3	7749
5.77/46	5.81/47	5.84/47	5.87/48	5.9/49	5.93/49	5.71/47	5.68/45	5.67/43	5.66/41	5.64/39	5.62/37				
9387	9287	9186	9084	8981	8877	8656	8424	8192	7960	7728	7496				
6.15/48	6.19/49	6.22/49	6.25/50	6.28/51	6.31/51	6.09/49	6.06/47	6.05/45	6.04/43	6.02/41	6.0/39	DP 40	1640	3	7943
9865	9764	9662	9559	9455	9350	9129	8897	8665	8433	8201	7969				
6.53/50	6.57/51	6.6/51	6.63/52	6.66/53	6.69/53	6.47/51	6.44/49	6.43/47	6.42/45	6.4/43	6.38/41				

Performance certified is for installation type B - free inlet, ducted outlet.
 Power Ratings (BHP) does not include drive losses.
 Performance ratings do not include the effects of appurtenances in the airstream.

The sound ratings shown are loudness values in fan sones @ 5' (1.5m) in a hemispherical free field calculated per AMCA Standard 301. Values shown are for installation type A - free inlet fan sone levels.



S&P USA Ventilation Systems, LLC., Div. of Soler & Palau Ventilation Group, certifies that the Models SQB shown herein are licensed to bear the AMCA Seal. The ratings shown are based on test and procedures performed in accordance with AMCA Publication 211 and AMCA Publication 311 and comply with the requirement of the AMCA Certified Ratings Program.





SQBHP 18

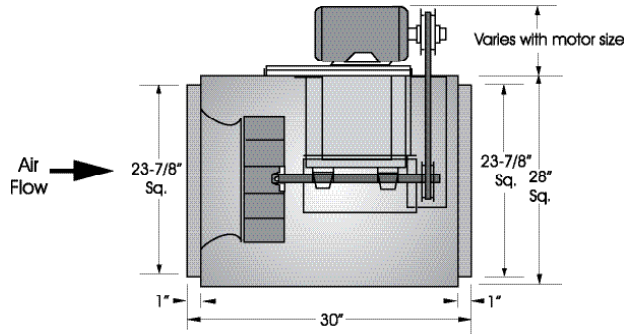

Outlet Velocity = CFM x 0.25
 Tip Speed = RPM x 4.843
 Maximum Motor Frame Size = 184T
 Maximum RPM = 1800
 Maximum BHP at a Given RPM = $(RPM/1251)^3$

Unit Specifications
 Housing Metal Thickness = 18 GA.
 Approximate Weight = 190 lbs.

CFM / BHP @ Static Pressure / Sones											Drive Range	RPM	HP	Tip Speed
3/4	1	1-1/4	1-1/2	1-3/4	2	2-1/4	2-1/2	2-3/4	3	3-1/4				
2119	-	-	-	-	-	-	-	-	-	-	DP 41	980	1/2	4746
.50/9.5	-	-	-	-	-	-	-	-	-	-				
2209	1559	-	-	-	-	-	-	-	-	-	DP 42	1000	1/2	4843
.53/9.9	.47/9.0	-	-	-	-	-	-	-	-	-				
2318	1845	-	-	-	-	-	-	-	-	-	DP 43	1025	3/4	4964
.57/10.6	.55/9.6	-	-	-	-	-	-	-	-	-				
2525	2165	-	-	-	-	-	-	-	-	-	DP 44	1075	3/4	5207
.65/11.9	.66/10.8	-	-	-	-	-	-	-	-	-				
2721	2416	1857	-	-	-	-	-	-	-	-	DP 45	1125	3/4	5449
.74/13.3	.76/12.2	.69/11.2	-	-	-	-	-	-	-	-				
2817	2530	2095	-	-	-	-	-	-	-	-	DP 46	1150	1	5570
.78/14.0	.81/12.9	.78/11.9	-	-	-	-	-	-	-	-				
3004	2746	2410	-	-	-	-	-	-	-	-	DP 47	1200	1	5812
.88/15.5	.91/14.3	.91/13.3	-	-	-	-	-	-	-	-				
3187	2950	2664	2216	-	-	-	-	-	-	-	DP 48	1250	1	6054
.98/17.0	1.02/15.8	1.04/14.7	.99/13.8	-	-	-	-	-	-	-				
3277	3049	2780	2403	-	-	-	-	-	-	-	DP 49	1275	1	6175
1.03/17.6	1.08/16.5	1.10/15.4	1.07/14.4	-	-	-	-	-	-	-				
3456	3242	3000	2696	2105	-	-	-	-	-	-	DP 50	1325	1-1/2	6417
1.15/18.8	1.20/17.8	1.23/16.7	1.23/15.7	1.10/14.8	-	-	-	-	-	-				
3632	3429	3207	2945	2581	-	-	-	-	-	-	DP 51	1375	1-1/2	6660
1.27/20	1.32/19.1	1.36/18.0	1.38/17.1	1.35/16.1	-	-	-	-	-	-				
3806	3613	3407	3172	2879	2374	-	-	-	-	-	DP 52	1425	1-1/2	6902
1.40/21	1.46/20	1.51/19.5	1.53/18.5	1.53/17.6	1.41/16.7	-	-	-	-	-				
3978	3794	3600	3385	3133	2793	-	-	-	-	-	DP 53	1475	2	7144
1.54/23	1.60/22	1.65/21	1.69/20	1.70/19.1	1.67/18.2	-	-	-	-	-				
4149	3973	3788	3589	3364	3087	2661	-	-	-	-	DP 54	1525	2	7386
1.68/24	1.75/23	1.81/22	1.86/21	1.88/21	1.87/19.7	1.78/18.8	-	-	-	-				
4234	4061	3881	3688	3473	3217	2863	-	-	-	-	DP 55	1550	2	7507
1.76/25	1.83/24	1.89/23	1.94/22	1.97/21	1.98/20	1.92/19.6	-	-	-	-				
4318	4149	3973	3786	3580	3340	3029	-	-	-	-	DP 56	1575	2	7628
1.84/25	1.91/25	1.98/24	2.03/23	2.06/22	2.08/21	2.04/20	-	-	-	-				
4403	4236	4065	3883	3685	3458	3178	2731	-	-	-	DP 57	1600	3	7749
1.92/26	2.00/25	2.06/25	2.12/24	2.16/23	2.18/22	2.16/21	2.03/20	-	-	-				
3881	3731	3573	3404	3217	3005	2757	2402	-	-	-	DP 58	1650	3	7991
1.88/24.8	1.95/23.6	2.01/22.5	2.05/22	2.08/21.6	2.09/21.3	2.07/21	2/20.8	-	-	-				
4025	3880	3730	3570	3396	3201	2980	2712	-	-	-	DP 59	1700	3	8234
2.05/26.2	2.12/25	2.18/23.9	2.23/23.2	2.27/22.8	2.29/22.5	2.28/22.1	2.25/21.8	-	-	-				
4168	4029	3884	3732	3568	3388	3187	2956	2653	-	-	DP 60	1750	3	8476
2.22/27.6	2.29/26.4	2.36/25.3	2.42/24.3	2.46/24	2.49/23.7	2.5/23.3	2.48/23	2.42/22.7	-	-				
4239	4102	3960	3812	3653	3479	3286	3068	2802	2359	-	DP 61	1775	3	8597
2.31/28.3	2.38/27.1	2.45/26	2.51/24.9	2.56/24.6	2.59/24.3	2.6/23.9	2.59/23.6	2.55/23.2	2.42/23	-				
4310	4175	4036	3892	3737	3568	3383	3176	2931	2575	-	DP 62	1800	3	8718
2.40/29.1	2.48/27.8	2.55/26.7	2.61/25.6	2.66/25.1	2.7/24.8	2.71/24.5	2.71/24.2	2.68/23.8	2.58/23.5	-				

Performance certified is for installation type B - free inlet, ducted outlet.
 Power Ratings (BHP) does not include drive losses.
 Performance ratings do not include the effects of appurtenances in the airstream.

The sound ratings shown are loudness values in fan sones @ 5' (1.5m) in a hemispherical free field calculated per AMCA Standard 301. Values shown are for installation type A - free inlet fan sone levels.



S&P USA Ventilation Systems, LLC., Div. of Soler & Palau Ventilation Group, certifies that the Models SQB shown herein are licensed to bear the AMCA Seal. The ratings shown are based on test and procedures performed in accordance with AMCA Publication 211 and AMCA Publication 311 and comply with the requirement of the AMCA Certified Ratings Program.





SQB 20

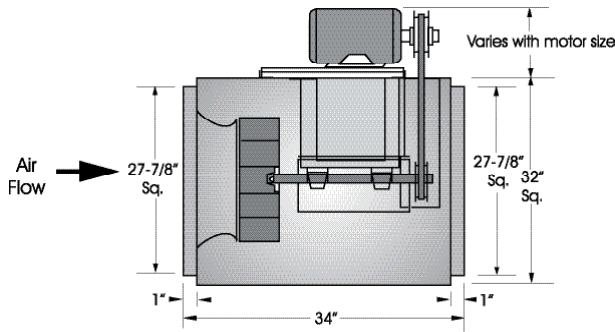

Outlet Velocity = CFM x 0.18
 Tip Speed = RPM x 5.629
 Maximum Motor Frame Size = 184T
 Maximum RPM = 1275
 Maximum BHP at a Given RPM = (RPM/870)³

Unit Specifications
 Housing Metal Thickness = 18 GA.
 Approximate Weight = 220 lbs.

CFM / BHP @ Static Pressure / Sones												Drive Range	RPM	HP	Tip Speed
1/8	1/4	3/8	1/2	5/8	3/4	1	1-1/4	1-1/2	1-3/4	2	2-1/4				
3297	2923	2428	-	-	-	-	-	-	-	-	-	DP 47	575	1/3	3236
.27/7.1	.29/6.9	.29/5.5	-	-	-	-	-	-	-	-	-				
3470	3118	2683	-	-	-	-	-	-	-	-	-	DP 48	600	1/3	3377
.30/7.7	.32/7.7	.33/6.3	-	-	-	-	-	-	-	-	-				
3539	3195	2778	2028	-	-	-	-	-	-	-	-	DP 49	610	1/3	3433
.32/8.0	.34/8.0	.35/6.7	.31/5.6	-	-	-	-	-	-	-	-				
3813	3496	3134	2646	-	-	-	-	-	-	-	-	DP 50	650	1/2	3659
.38/8.9	.40/8.9	.42/8.1	.41/6.7	-	-	-	-	-	-	-	-				
3982	3681	3344	2920	2054	-	-	-	-	-	-	-	DP 51	675	1/2	3799
.43/9.4	.45/9.4	.47/8.8	.47/7.5	.39/6.6	-	-	-	-	-	-	-				
4151	3862	3546	3167	2603	-	-	-	-	-	-	-	DP 52	700	1/2	3940
.47/10.0	.50/9.9	.52/9.6	.52/8.3	.50/7.3	-	-	-	-	-	-	-				
4486	4220	3935	3615	3217	2551	-	-	-	-	-	-	DP 53	750	3/4	4222
.58/11.2	.60/11.0	.63/10.8	.64/9.9	.64/8.8	.58/8.0	-	-	-	-	-	-				
4653	4396	4125	3824	3468	2971	-	-	-	-	-	-	DP 54	775	3/4	4362
.63/11.9	.66/11.5	.69/11.4	.71/10.7	.71/9.6	.68/8.8	-	-	-	-	-	-				
4819	4571	4311	4028	3702	3286	-	-	-	-	-	-	DP 55	800	3/4	4503
.69/12.6	.73/12.3	.75/12.0	.77/11.6	.78/10.5	.77/9.6	-	-	-	-	-	-				
5051	4814	4568	4305	4011	3661	-	-	-	-	-	-	DP 56	835	1	4700
.79/13.6	.82/13.4	.85/13.1	.87/12.9	.89/11.9	.89/10.9	-	-	-	-	-	-				
5216	4987	4750	4498	4222	3904	2801	-	-	-	-	-	DP 57	860	1	4841
.86/14.4	.89/14.2	.92/13.9	.95/13.7	.97/12.9	.97/11.9	.85/10.2	-	-	-	-	-				
5380	5158	4929	4688	4427	4134	3286	-	-	-	-	-	DP 58	885	1	4981
.93/15.2	.97/15.0	1.00/14.7	1.03/14.5	1.05/14.0	1.06/12.9	1.00/11.1	-	-	-	-	-				
5643	5431	5214	4987	4746	4482	3809	-	-	-	-	-	DP 59	925	1-1/2	5207
1.10/16.3	1.13/16.1	1.16/16.0	1.19/15.8	1.20/14.7	1.19/12.7	-	-	-	-	-	-				
5970	5769	5565	5354	5132	4895	4335	3429	-	-	-	-	DP 60	975	1-1/2	5488
1.24/18.2	1.28/18.0	1.32/17.9	1.35/17.7	1.38/17.6	1.40/17.0	1.41/14.9	1.30/13.1	-	-	-	-				
6199	6005	5809	5607	5396	5173	4665	3963	-	-	-	-	DP 61	1010	1-1/2	5685
1.37/19.4	1.41/19.2	1.45/19.1	1.49/19.0	1.52/18.9	1.55/18.7	1.57/16.6	1.52/14.6	-	-	-	-				
6296	6106	5912	5714	5508	5291	4801	4150	-	-	-	-	DP 62	1025	2	5769
1.43/20	1.48/19.8	1.52/19.7	1.55/19.5	1.59/19.4	1.61/19.4	1.64/17.3	1.61/15.3	-	-	-	-				
6622	6440	6256	6069	5876	5675	5233	4697	3880	-	-	-	DP 63	1075	2	6051
1.65/22	1.69/22	1.74/22	1.78/22	1.81/21	1.84/21	1.89/19.8	1.89/17.7	1.77/15.9	-	-	-				
6849	6673	6496	6315	6130	5938	5523	5038	4388	-	-	-	DP 64	1110	2	6248
1.81/23	1.86/23	1.90/23	1.95/23	1.98/23	2.02/23	2.07/22	2.09/19.5	2.03/17.6	-	-	-				
7108	6938	6768	6594	6417	6235	5845	5403	4856	3987	-	-	DP 65	1150	3	6473
2.01/25	2.06/25	2.11/25	2.15/25	2.19/24	2.23/24	2.29/24	2.32/22	2.30/19.6	2.12/17.8	-	-				
7431	7269	7106	6940	6772	6600	6237	5835	5366	4753	-	-	DP 66	1200	3	6754
2.28/27	2.33/27	2.38/27	2.43/27	2.47/27	2.51/27	2.58/27	2.63/25	2.63/22	2.56/20	-	-				
7754	7598	7442	7284	7124	6960	6618	6248	5831	5329	4622	-	DP 67	1250	3	7036
2.57/29	2.63/29	2.68/29	2.73/29	2.78/29	2.82/29	2.90/29	2.95/28	2.98/25	2.96/23	2.81/21	-				
7916	7763	7609	7455	7298	7138	6806	6450	6053	5588	4979	3527	DP 68	1275	3	7177
2.73/30	2.78/30	2.84/30	2.89/30	2.94/30	2.98/30	3.06/30	3.12/29	3.16/27	3.15/24	3.06/22	2.48/21				

Performance certified is for installation type B - free inlet, ducted outlet.
 Power Ratings (BHP) does not include drive losses.
 Performance ratings do not include the effects of appurtenances in the airstream.

The sound ratings shown are loudness values in fan sones @ 5' (1.5m) in a hemispherical free field calculated per AMCA Standard 301. Values shown are for installation type A - free inlet fan sone levels.



S&P USA Ventilation Systems, LLC., Div. of Soler & Palau Ventilation Group, certifies that the Models SQB shown herein are licensed to bear the AMCA Seal. The ratings shown are based on test and procedures performed in accordance with AMCA Publication 211 and AMCA Publication 311 and comply with the requirement of the AMCA Certified Ratings Program.





SQBHP 20

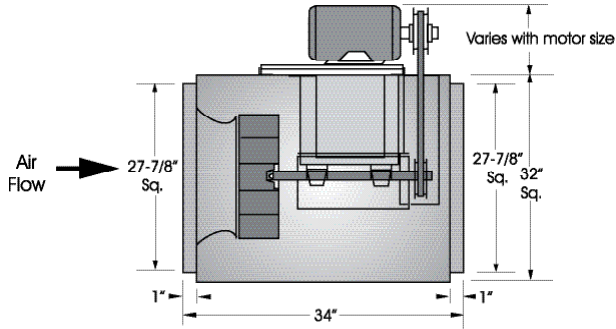

Outlet Velocity = CFM x 0.18
 Tip Speed = RPM x 5.629
 Maximum Motor Frame Size = 184T
 Maximum RPM = 1440
 Maximum BHP at a Given RPM = (RPM/988)³

Unit Specifications
 Housing Metal Thickness = 18 GA.
 Approximate Weight = 220 lbs.

CFM / BHP @ Static Pressure / Sones									Drive Range	RPM	HP	Tip Speed
3/4	1	1-1/4	1-1/2	1-3/4	2	2-1/4	2-1/2	2-3/4				
2876	1908								DP 54	850	3/4	4784
.65/10.1	.56/9.1	-	-	-	-	-	-	-		DP 55	875	3/4
3051	2380								DP 56		900	3/4
.70/10.9	.67/9.7	-	-	-	-	-	-	-		DP 57	950	1
3218	2656								DP 58		1000	1
.76/11.8	.75/10.4	-	-	-	-	-	-	-		DP 59	1025	1-1/2
3536	3086	2120							DP 60		1075	1-1/2
.89/13.9	.90/11.9	.78/10.9	-	-	-	-	-	-		DP 61	1100	1-1/2
3839	3452	2907							DP 62		1125	1-1/2
1.02/15.6	1.05/13.7	1.03/12.4	-	-	-	-	-	-		DP 63	1145	1-1/2
3986	3622	3144							DP 64		1150	2
1.09/16.4	1.13/14.8	1.12/13.2	-	-	-	-	-	-		DP 65	1175	2
4275	3946	3549	2957						DP 66		1200	2
1.25/18.1	1.29/17.2	1.31/14.9	1.26/13.7	-	-	-	-	-		DP 67	1225	2
4416	4102	3732	3230						DP 68		1250	2
1.33/19.0	1.38/18.2	1.40/16.0	1.38/14.6	-	-	-	-	-		DP 69	1300	3
4557	4254	3907	3463	2546					DP 70		1325	3
1.41/19.9	1.47/19.2	1.50/17.2	1.49/15.4	1.31/14.5	-	-	-	-		DP 71	1350	3
4668	4375	4043	3632	2974					DP 72		1375	3
1.48/21	1.54/19.9	1.58/18.1	1.58/16.1	1.48/15.1	-	-	-	-		DP 73	1400	3
4696	4405	4076	3673	3048					DP 74		1425	3
1.50/21	1.56/20	1.60/18.4	1.60/16.3	1.52/15.3	-	-	-	-		DP 75	1440	3
4834	4553	4240	3868	3353					DP 76			
1.59/22	1.65/21	1.70/19.7	1.71/17.5	1.66/16.1	-	-	-	-		DP 77		
4971	4699	4400	4053	3603	2601				DP 78			
1.68/23	1.75/22	1.80/21	1.82/18.7	1.80/17.0	1.55/16.2	-	-	-		DP 79		
5107	4843	4556	4229	3826	3194				DP 80			
1.78/24	1.85/23	1.90/22	1.93/19.9	1.93/18.0	1.82/17.0	-	-	-		DP 81		
5242	4986	4709	4400	4030	3517				DP 82			
1.88/25	1.96/24	2.01/23	2.05/21	2.06/19.1	1.99/17.9	-	-	-		DP 83		
5510	5267	5009	4727	4405	4007	3398			DP 84			
2.09/26	2.18/25	2.24/25	2.29/24	2.32/21	2.30/19.6	2.18/18.8	-	-		DP 85		
5643	5406	5156	4885	4581	4218	3721			DP 86			
2.20/27	2.29/26	2.36/26	2.42/25	2.45/23	2.44/21	2.37/19.6	-	-		DP 87		
5775	5544	5302	5041	4751	4415	3984	3203		DP 88			
2.32/27	2.41/27	2.49/26	2.55/26	2.58/24	2.59/22	2.55/20	2.32/19.6	-		DP 89		
5907	5681	5445	5193	4917	4602	4216	3650		DP 90			
2.44/28	2.53/28	2.61/27	2.68/27	2.72/25	2.74/23	2.72/21	2.59/20	-		DP 91		
6039	5818	5588	5344	5079	4782	4430	3959		DP 92			
2.56/29	2.66/29	2.75/28	2.81/27	2.86/26	2.89/24	2.88/22	2.80/21	-		DP 93		
6170	5953	5729	5493	5238	4956	4629	4219	3554	DP 94			
2.69/29	2.79/29	2.88/29	2.95/28	3.01/27	3.04/25	3.05/23	3.00/22	2.80/21		DP 95		
6248	6035	5814	5581	5332	5058	4744	4360	3798	DP 96			
2.77/30	2.88/30	2.96/29	3.04/29	3.10/28	3.14/26	3.15/24	3.11/23	2.97/22		DP 97		

Performance certified is for installation type B - free inlet, ducted outlet.
 Power Ratings (BHP) does not include drive losses.
 Performance ratings do not include the effects of appurtenances in the airstream.

The sound ratings shown are loudness values in fan sones @ 5' (1.5m) in a hemispherical free field calculated per AMCA Standard 301. Values shown are for installation type A - free inlet fan sone levels.



S&P USA Ventilation Systems, LLC., Div. of Soler & Palau Ventilation Group, certifies that the Models SQB shown herein are licensed to bear the AMCA Seal. The ratings shown are based on test and procedures performed in accordance with AMCA Publication 211 and AMCA Publication 311 and comply with the requirement of the AMCA Certified Ratings Program.



SQB 24

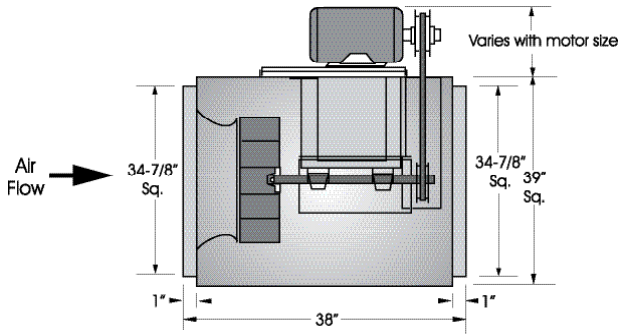

Outlet Velocity = CFM x 0.11
 Tip Speed = RPM x 6.48
 Maximum Motor Frame Size = 215T
 Maximum RPM = 1235
 Maximum BHP at a Given RPM = (RPM/711)³

Unit Specifications
 Housing Metal Thickness = 18 GA.
 Approximate Weight = 320 lbs.

CFM / BHP @ Static Pressure / Sones													Drive Range	RPM	HP	Tip Speed	
1/8	1/4	3/8	1/2	5/8	3/4	1	1-1/4	1-1/2	1-3/4	2	2-1/4						
4426	3956	3416	2395	-	-	-	-	-	-	-	-	-	DP 59	DP 60	530	1/2	3434
.39/8.0	.41/7.5	.42/6.4	.36/5.5	-	-	-	-	-	-	-	-	-			570	1/2	3693
4828	4394	3928	3325	-	-	-	-	-	-	-	-	-			580	1/2	3758
4928	4502	4049	3485	-	-	-	-	-	-	-	-	-	DP 61	DP 61	600	3/4	3888
.50/9.3	.53/9.0	.54/8.0	.54/7.1	-	-	-	-	-	-	-	-	-			660	3/4	4276
5127	4715	4286	3779	2949	-	-	-	-	-	-	-	-			675	1	4374
.55/9.8	.58/9.6	.60/8.7	.60/7.8	.55/6.9	-	-	-	-	-	-	-	-	DP 62	DP 62	725	1	4698
5720	5343	4966	4558	4070	3307	-	-	-	-	-	-	-			775	1-1/2	5022
.72/11.6	.76/11.4	.79/11.0	.80/9.9	.80/9.0	.74/8.2	-	-	-	-	-	-	-			820	1-1/2	5313
5867	5498	5131	4738	4284	3653	-	-	-	-	-	-	-	DP 63	DP 63	830	1-1/2	5378
.77/12.1	.81/11.8	.84/11.5	.86/10.5	.86/9.6	.83/8.8	-	-	-	-	-	-	-			845	2	5475
6356	6010	5670	5319	4937	4488	-	-	-	-	-	-	-			900	2	5832
.95/13.8	.99/13.6	1.02/13.4	1.05/12.6	1.07/11.6	1.06/10.8	-	-	-	-	-	-	-	DP 64	DP 64	910	2	5896
6843	6515	6198	5876	5538	5166	4126	-	-	-	-	-	-			935	3	6058
1.15/15.7	1.20/15.4	1.24/15.2	1.27/14.9	1.29/13.9	1.30/13.0	1.24/11.3	-	-	-	-	-	-			1010	3	6544
7278	6966	6665	6364	6053	5723	4925	-	-	-	-	-	-	DP 65	DP 65	1035	3	6706
1.36/17.5	1.41/17.3	1.45/17.0	1.49/16.8	1.52/16.0	1.54/15.1	1.53/13.3	-	-	-	-	-	-			1045	5	6771
7375	7066	6768	6471	6165	5843	5076	-	-	-	-	-	-			1080	5	6998
1.41/17.9	1.46/17.7	1.50/17.4	1.54/17.2	1.57/16.5	1.59/15.5	1.59/13.8	-	-	-	-	-	-	1120	5	7257		
7519	7215	6922	6631	6333	6020	5295	4060	-	-	-	-	-	1190	5	7711		
1.48/18.5	1.53/18.3	1.58/18.1	1.62/17.9	1.65/17.3	1.68/16.3	1.68/14.5	1.53/12.9	-	-	-	-	-	1225	5	7937		
8049	7760	7483	7210	6934	6650	6030	5237	-	-	-	-	-	1235	5	8002		
1.78/21	1.84/21	1.89/20	1.94/20	1.97/20	2.01/19.1	2.04/17.3	2.00/15.5	-	-	-	-	-					
8145	7859	7584	7314	7042	6763	6156	5400	-	-	-	-	-					
1.84/21	1.90/21	1.95/21	2.00/21	2.04/20	2.07/19.6	2.11/17.8	2.08/16.1	-	-	-	-	-					
8384	8105	7837	7574	7310	7040	6465	5779	4720	-	-	-	-					
2.00/22	2.05/22	2.11/22	2.16/22	2.20/22	2.23/21	2.28/19.1	2.28/17.4	2.13/15.8	-	-	-	-					
9102	8840	8589	8344	8100	7855	7348	6790	6119	5100	-	-	-					
2.50/26	2.57/26	2.63/25	2.68/25	2.73/25	2.78/25	2.85/23	2.88/21	2.86/19.7	2.68/18.2	-	-	-					
9340	9084	8838	8598	8360	8122	7632	7101	6486	5659	-	-	-					
2.69/27	2.76/27	2.82/27	2.88/26	2.93/26	2.98/26	3.05/25	3.10/23	3.09/21	2.99/19.5	-	-	-					
9436	9181	8937	8699	8464	8228	7744	7224	6626	5849	-	-	-					
2.77/28	2.84/27	2.90/27	2.96/27	3.01/27	3.06/26	3.14/25	3.19/23	3.19/22	3.10/20	-	-	-					
9769	9521	9284	9053	8825	8597	8133	7643	7098	6441	5459	-	-					
3.05/29	3.12/29	3.19/29	3.25/28	3.31/28	3.36/28	3.44/27	3.50/25	3.53/24	3.49/22	3.28/20	-	-					
10149	9909	9679	9455	9234	9015	8571	8109	7608	7035	6305	4831	-					
3.40/31	3.47/31	3.54/30	3.60/30	3.66/30	3.72/29	3.82/29	3.89/27	3.93/25	3.92/24	3.82/22	3.33/21	-					
10814	10586	10367	10154	9945	9738	9324	8900	8454	7970	7416	6425	-					
4.06/34	4.14/33	4.22/33	4.29/33	4.36/33	4.42/32	4.53/32	4.62/31	4.68/29	4.72/27	4.70/26	4.59/24	-					
11145	10923	10710	10502	10298	10096	9695	9286	8861	8407	7903	7309	-					
4.43/35	4.51/35	4.59/35	4.66/34	4.73/34	4.80/34	4.91/33	5.01/33	5.09/31	5.14/29	5.14/28	5.09/26	-					
11240	11019	10807	10601	10399	10198	9800	9396	8976	8529	8037	7464	-					
4.54/36	4.62/35	4.70/35	4.77/35	4.84/35	4.91/34	5.03/34	5.13/33	5.21/31	5.26/30	5.27/28	5.23/27	-					



Performance certified is for installation type B - free inlet, ducted outlet.
 Power Ratings (BHP) does not include drive losses.
 Performance ratings do not include the effects of appurtenances in the airstream.

The sound ratings shown are loudness values in fan sones @ 5' (1.5m) in a hemispherical free field calculated per AMCA Standard 301. Values shown are for installation type A - free inlet fan sone levels.



S&P USA Ventilation Systems, LLC., Div. of Soler & Palau Ventilation Group, certifies that the Models SQB shown herein are licensed to bear the AMCA Seal. The ratings shown are based on test and procedures performed in accordance with AMCA Publication 211 and AMCA Publication 311 and comply with the requirement of the AMCA Certified Ratings Program.



SQBHP 24

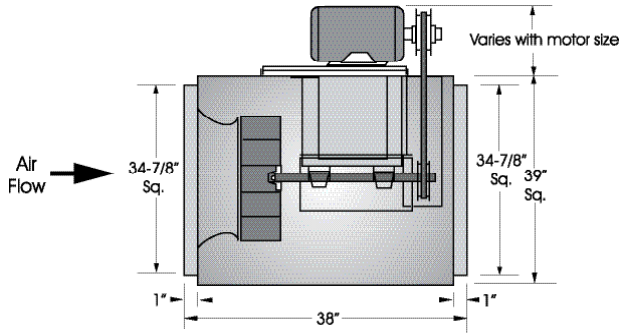

Outlet Velocity = CFM x 0.11
 Tip Speed = RPM x 6.48
 Maximum Motor Frame Size = 215T
 Maximum RPM = 1515
 Maximum BHP at a Given RPM = $(RPM/774)^3$

Unit Specifications
 Housing Metal Thickness = 18 GA.
 Approximate Weight = 320 lbs.

CFM / BHP @ Static Pressure / Sones											Drive Range	RPM	HP	Tip Speed	
3/4	1	1-1/4	1-1/2	1-3/4	2	2-1/4	2-1/2	2-3/4	3	3-1/4					3-1/2
4251	3195	-	-	-	-	-	-	-	-	-	-	DP 66	765	1	4957
.99/12.0	.91/10.4	-	-	-	-	-	-	-	-	-	-				
4474	3589	-	-	-	-	-	-	-	-	-	-	DP 67	785	1	5086
1.07/12.8	1.03/11.7	-	-	-	-	-	-	-	-	-	-				
4794	4054	-	-	-	-	-	-	-	-	-	-	DP 68	815	1-1/2	5281
1.19/14.0	1.18/12.8	-	-	-	-	-	-	-	-	-	-				
5251	4635	3676	-	-	-	-	-	-	-	-	-	DP 69	860	1-1/2	5572
1.38/15.8	1.40/14.7	1.31/13.2	-	-	-	-	-	-	-	-	-				
5641	5095	4370	-	-	-	-	-	-	-	-	-	DP 69	900	1-1/2	5832
1.56/17.5	1.61/16.4	1.58/15.3	-	-	-	-	-	-	-	-	-				
5973	5472	4853	3868	-	-	-	-	-	-	-	-	DP 69	935	2	6058
1.74/19.1	1.79/18.0	1.80/16.8	1.66/15.1	-	-	-	-	-	-	-	-				
6159	5680	5103	4281	-	-	-	-	-	-	-	-	DP 69	955	2	6188
1.84/20	1.90/18.9	1.92/17.8	1.84/16.7	-	-	-	-	-	-	-	-				
6481	6034	5515	4848	3558	-	-	-	-	-	-	-	DP 69	990	2	6415
2.03/22	2.10/20	2.14/19.4	2.11/18.4	1.81/15.6	-	-	-	-	-	-	-				
6887	6473	6008	5453	4687	-	-	-	-	-	-	-	DP 69	1035	3	6706
2.29/24	2.38/23	2.44/21	2.44/20	2.35/19.5	-	-	-	-	-	-	-				
7331	6947	6527	6047	5458	4589	-	-	-	-	-	-	DP 69	1085	3	7030
2.61/26	2.71/25	2.78/24	2.82/23	2.79/22	2.62/20	-	-	-	-	-	-				
7725	7364	6974	6542	6039	5400	4319	-	-	-	-	-	DP 70	1130	3	7322
2.92/27	3.03/27	3.11/25	3.17/24	3.18/23	3.11/23	2.80/20	-	-	-	-	-				
7985	7637	7265	6857	6395	5836	5059	-	-	-	-	-	DP 70	1160	5	7516
3.14/28	3.25/28	3.35/27	3.42/26	3.45/25	3.41/24	3.25/23	-	-	-	-	-				
8330	7997	7645	7265	6844	6357	5750	4815	-	-	-	-	DP 70	1200	5	7775
3.45/30	3.57/30	3.68/28	3.76/27	3.81/26	3.81/25	3.73/25	3.45/22	-	-	-	-				
8671	8352	8018	7660	7272	6835	6321	5654	4413	-	-	-	DP 70	1240	5	8035
3.77/31	3.91/31	4.02/30	4.11/29	4.18/28	4.21/27	4.18/26	4.05/25	3.54/22	-	-	-				
8968	8660	8339	7999	7633	7230	6770	6213	5440	-	-	-	DP 70	1275	5	8261
4.08/33	4.22/33	4.34/32	4.44/31	4.52/30	4.57/29	4.57/28	4.50/27	4.27/26	-	-	-				
9179	8878	8566	8237	7885	7502	7072	6567	5921	4817	-	-	DP 70	1300	5	8423
4.30/34	4.45/34	4.58/33	4.69/32	4.77/31	4.83/30	4.85/29	4.81/28	4.66/27	4.19/25	-	-				
9431	9139	8836	8519	8183	7820	7419	6962	6408	5645	-	-	DP 70	1330	5	8618
4.59/35	4.74/35	4.87/34	4.99/33	5.09/32	5.16/31	5.19/31	5.18/30	5.09/29	4.84/27	-	-				
9891	9613	9326	9028	8715	8382	8023	7626	7174	6630	5891	-	DP 71	1385	7 1/2	8974
5.14/37	5.30/37	5.44/37	5.58/36	5.69/35	5.78/34	5.84/33	5.86/32	5.84/32	5.74/31	5.47/29	-				
10223	9954	9678	9392	9094	8779	8443	8078	7673	7207	6637	5829	DP 71	1425	7 1/2	9233
5.56/39	5.73/39	5.89/39	6.03/38	6.15/37	6.25/36	6.33/35	6.38/34	6.38/34	6.34/33	6.19/32	5.84/30				
10513	10251	9984	9707	9420	9119	8800	8458	8084	7665	7176	6562	DP 71	1460	7 1/2	9460
5.96/41	6.13/41	6.29/41	6.44/40	6.57/39	6.68/38	6.77/37	6.84/36	6.87/36	6.85/35	6.77/34	6.57/33				
10760	10505	10244	9975	9697	9406	9100	8774	8422	8034	7593	7068	DP 71	1490	7 1/2	9564
6.31/42	6.49/42	6.66/42	6.81/42	6.95/41	7.07/40	7.17/39	7.25/38	7.29/37	7.30/36	7.25/36	7.12/35				
10996	10716	10460	10197	9925	9642	9346	9032	8696	8329	7919	7445	DP 71	1515	7 1/2	9816
6.61/43	6.80/43	6.97/43	7.13/43	7.27/42	7.40/41	7.51/40	7.59/40	7.65/39	7.68/38	7.65/37	7.56/36				

Performance certified is for installation type B - free inlet, ducted outlet.
 Power Ratings (BHP) does not include drive losses.
 Performance ratings do not include the effects of appurtenances in the airstream.

The sound ratings shown are loudness values in fan sones @ 5' (1.5m) in a hemispherical free field calculated per AMCA Standard 301. Values shown are for installation type A - free inlet fan sone levels.



S&P USA Ventilation Systems, LLC., Div. of Soller & Palau Ventilation Group, certifies that the Models SQB shown herein are licensed to bear the AMCA Seal. The ratings shown are based on test and procedures performed in accordance with AMCA Publication 211 and AMCA Publication 311 and comply with the requirement of the AMCA Certified Ratings Program.



SQB 30

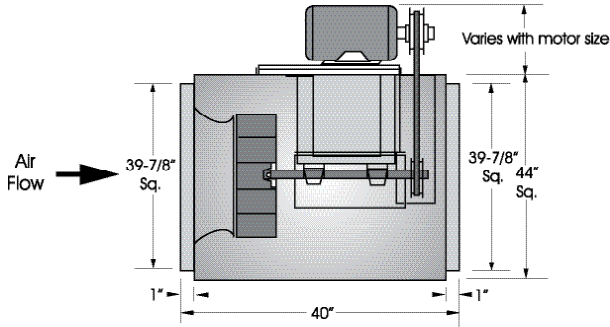

Outlet Velocity = CFM x 0.09
 Tip Speed = RPM x 8.017
 Maximum Motor Frame Size = 215T
 Maximum RPM = 1000
 Maximum BHP at a Given RPM = (RPM/510)³

Unit Specifications
 Housing Metal Thickness = 16 GA.
 Approximate Weight = 420 lbs.

CFM / BHP @ Static Pressure / Sones											Drive Range	RPM	HP	Tip Speed		
1/8	1/4	3/8	1/2	5/8	3/4	1	1-1/4	1-1/2	1-3/4	2					2-1/4	
5919	5239	4395	-	-	-	-	-	-	-	-	-	DP 72	425	3/4	3407	
.53/7.6	.57/7.1	.58/6.4	-	-	-	-	-	-	-	-	-		DP 73	450	3/4	3608
6341	5711	4978	3879	-	-	-	-	-	-	-	-			470	3/4	3768
6675	6079	5408	4526	-	-	-	-	-	-	-	-	DP 74	500	1	4009	
.71/9.3	.75/8.8	.78/8.1	.77/7.3	-	-	-	-	-	-	-	-		DP 75	520	1	4169
7174	6619	6017	5300	4214	-	-	-	-	-	-	-			550	1-1/2	4410
.85/10.6	.90/10.0	.93/9.5	.94/8.6	.89/7.8	-	-	-	-	-	-	-	DP 76	575	1-1/2	4610	
7503	6972	6406	5757	4900	-	-	-	-	-	-	-		DP 77	590	1-1/2	4730
.95/11.6	1.00/10.9	1.04/10.4	1.06/9.6	1.04/8.7	-	-	-	-	-	-	-			625	2	5011
7995	7496	6973	6397	5707	4707	-	-	-	-	-	-	DP 78	650	2	5211	
1.12/13.0	1.17/12.4	1.22/11.9	1.25/11.2	1.25/10.2	1.19/9.4	-	-	-	-	-	-		700	3	5612	
8403	7926	7433	6901	6294	5525	-	-	-	-	-	-		DP 77	725	3	5813
1.28/14.3	1.33/13.7	1.38/13.2	1.42/12.6	1.43/11.7	1.41/10.7	-	-	-	-	-	-	DP 78		750	3	6013
8646	8182	7705	7196	6625	5935	-	-	-	-	-	-			800	5	6414
1.37/15.1	1.43/14.5	1.48/14.0	1.52/13.4	1.55/12.5	1.54/11.6	-	-	-	-	-	-	DP 77	825	5	6615	
9212	8775	8330	7863	7358	6784	5002	-	-	-	-	-		DP 78	850	5	6815
1.63/16.8	1.69/16.3	1.75/15.8	1.79/15.3	1.83/14.7	1.84/13.7	1.69/11.8	-	-	-	-	-			875	5	7015
9615	9195	8770	8328	7857	7337	5958	-	-	-	-	-	DP 77	885	5	7096	
1.82/17.9	1.89/17.4	1.95/16.9	2.00/16.4	2.04/15.9	2.07/15.0	2.01/13.2	-	-	-	-	-		DP 78	925	7 1/2	7416
10417	10027	9635	9233	8815	8369	7324	5651	-	-	-	-			950	7 1/2	7617
2.27/20	2.34/19.5	2.40/19.0	2.47/18.6	2.52/18.2	2.56/17.8	2.58/16.0	2.38/14.4	-	-	-	-	DP 77	975	7 1/2	7817	
10817	10440	10062	9677	9279	8860	7909	6605	-	-	-	-		DP 78	1000	7 1/2	8018
2.51/21	2.59/21	2.66/20	2.72/19.7	2.78/19.3	2.83/18.9	2.88/17.4	2.78/15.9	-	-	-	-			1000	7 1/2	8018
11215	10851	10487	10116	9736	9339	8461	7349	5116	-	-	-	DP 77	1000	7 1/2	8018	
2.78/22	2.85/22	2.93/21	3.00/21	3.06/20	3.11/20	3.18/18.9	3.15/17.4	2.65/16.0	-	-	-		DP 78	1000	7 1/2	8018
12010	11669	11327	10983	10632	10271	9497	8601	7420	-	-	-			1000	7 1/2	8018
3.36/25	3.44/24	3.52/24	3.60/24	3.67/23	3.73/23	3.83/22	3.86/20	3.76/19.1	-	-	-	DP 77	1000	7 1/2	8018	
12407	12075	11744	11412	11074	10727	9993	9165	8144	6529	-	-		DP 78	1000	7 1/2	8018
3.68/26	3.76/26	3.85/25	3.92/25	4.00/25	4.07/24	4.18/24	4.24/22	4.19/21	3.86/19.3	-	-			1000	7 1/2	8018
12803	12481	12160	11837	11511	11178	10478	9704	8791	7552	-	-	DP 77	1000	7 1/2	8018	
4.02/27	4.10/27	4.19/27	4.27/26	4.35/26	4.42/26	4.54/25	4.62/24	4.62/22	4.45/21	-	-		DP 78	1000	7 1/2	8018
13198	12885	12573	12260	11945	11623	10953	10224	9390	8344	6595	-			1000	7 1/2	8018
4.38/29	4.47/28	4.56/28	4.64/28	4.72/27	4.80/27	4.93/26	5.03/25	5.06/24	4.96/22	4.48/21	-	DP 77	1000	7 1/2	8018	
13356	13046	12738	12429	12117	11800	11141	10428	9620	8629	7128	-		DP 78	1000	7 1/2	8018
4.53/29	4.62/29	4.71/29	4.79/28	4.88/28	4.95/28	5.09/27	5.19/26	5.23/25	5.16/23	4.80/22	-			1000	7 1/2	8018
13987	13691	13396	13100	12803	12503	11883	11224	10500	9665	8607	6796	DP 77	1000	7 1/2	8018	
5.16/32	5.26/32	5.35/31	5.44/31	5.53/30	5.61/30	5.76/29	5.89/29	5.96/27	5.96/26	5.82/24	5.21/23		DP 78	1000	7 1/2	8018
14381	14092	13805	13518	13229	12937	12339	11708	11025	10256	9332	8049			1000	7 1/2	8018
5.58/34	5.68/33	5.78/33	5.87/32	5.96/32	6.05/32	6.21/31	6.35/30	6.44/29	6.47/28	6.40/26	6.09/25	DP 77	1000	7 1/2	8018	
14775	14493	14213	13933	13652	13369	12790	12184	11535	10819	9988	8936		DP 78	1000	7 1/2	8018
6.03/35	6.13/35	6.23/35	6.33/34	6.42/34	6.51/33	6.68/33	6.83/32	6.94/31	6.99/29	6.97/28	6.79/27			1000	7 1/2	8018
15168	14893	14620	14347	14074	13798	13237	12654	12034	11360	10599	9686	DP 77	1000	7 1/2	8018	
6.50/37	6.61/37	6.71/36	6.81/36	6.91/35	7.00/35	7.18/34	7.33/34	7.45/33	7.53/31	7.54/30	7.44/28		DP 78	1000	7 1/2	8018
15561	15293	15025	14757	14489	14221	13660	13099	12479	11804	11003	9986			1000	7 1/2	8018



Performance certified is for installation type B - free inlet, ducted outlet.
 Power Ratings (BHP) does not include drive losses.
 Performance ratings do not include the effects of apertures in the airstream.

The sound ratings shown are loudness values in fan sones @ 5' (1.5m) in a hemispherical free field calculated per AMCA Standard 301. Values shown are for installation type A - free inlet fan sone levels.



S&P USA Ventilation Systems, LLC., Div. of Soler & Palou Ventilation Group, certifies that the Models SQB shown herein are licensed to bear the AMCA Seal. The ratings shown are based on test and procedures performed in accordance with AMCA Publication 211 and AMCA Publication 311 and comply with the requirement of the AMCA Certified Ratings Program.





SQBHP 30

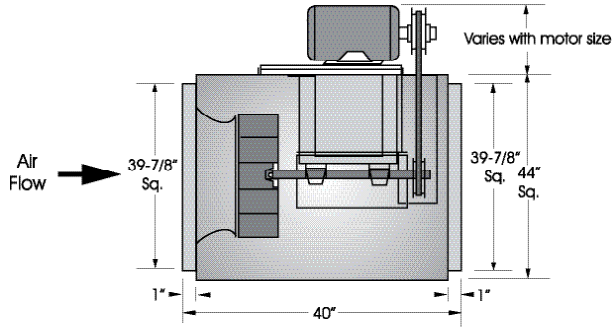

Outlet Velocity = CFM x 0.09
 Tip Speed = RPM x 8.017
 Maximum Motor Frame Size = 215T
 Maximum RPM = 1120
 Maximum BHP at a Given RPM = $(RPM/572)^3$

Unit Specifications
 Housing Metal Thickness = 16 GA.
 Approximate Weight = 420 lbs.

CFM / BHP @ Static Pressure / Sones											Drive Range	RPM	HP	Tip Speed	
3/4	1	1-1/4	1-1/2	1-3/4	2	2-1/4	2-1/2	2-3/4	3	3-1/4					3-1/2
5295	3906	-	-	-	-	-	-	-	-	-	-	DP 79	615	1-1/2	4931
1.26/12.0	1.18/10.8	-	-	-	-	-	-	-	-	-	-		640	1-1/2	5131
5739	4646	-	-	-	-	-	-	-	-	-	-		660	1-1/2	5292
6078	5117	-	-	-	-	-	-	-	-	-	-	DP 80	690	2	5532
1.55/14.2	1.55/13.0	-	-	-	-	-	-	-	-	-	-		710	2	5692
6565	5735	4452	-	-	-	-	-	-	-	-	-		725	2	5813
1.75/15.8	1.78/14.5	1.68/13.3	-	-	-	-	-	-	-	-	-	DP 81	735	2	5893
6880	6112	5051	-	-	-	-	-	-	-	-	-		765	3	6133
1.90/16.9	1.94/15.6	1.89/14.4	-	-	-	-	-	-	-	-	-		785	3	6494
7112	6382	5426	-	-	-	-	-	-	-	-	-	DP 82	810	3	6494
2.01/17.7	2.06/16.5	2.04/15.2	-	-	-	-	-	-	-	-	-		830	3	6655
8011	7393	6670	5720	-	-	-	-	-	-	-	-		835	5	6695
2.51/21	2.59/19.8	2.62/18.6	2.57/17.4	-	-	-	-	-	-	-	-	DP 83	900	5	7216
8375	7790	7125	6304	5034	-	-	-	-	-	-	-		920	5	7376
2.73/22	2.83/21	2.88/19.9	2.86/18.8	2.68/17.8	-	-	-	-	-	-	-		945	5	7577
8663	8102	7474	6725	5696	-	-	-	-	-	-	-	DP 82	975	5	7817
2.92/23	3.03/22	3.09/21	3.10/19.9	2.99/18.9	-	-	-	-	-	-	-		990	5	7937
8734	8179	7559	6826	5838	-	-	-	-	-	-	-		1020	7 1/2	8178
2.97/23	3.08/23	3.14/21	3.15/20	3.06/19.2	-	-	-	-	-	-	-	DP 83	1045	7 1/2	8378
9651	9155	8622	8028	7334	6439	4783	-	-	-	-	-		1090	7 1/2	8739
3.65/26	3.79/26	3.89/25	3.94/24	3.95/23	3.86/22	3.43/21	-	-	-	-	-		1110	7 1/2	8900
9929	9448	8935	8371	7726	6933	5767	-	-	-	-	-	DP 83	1120	7 1/2	8980
3.88/27	4.02/27	4.13/26	4.20/25	4.22/24	4.17/23	3.94/22	-	-	-	-	-		12632	7.11/38	7.27/37
10273	9810	9319	8787	8191	7488	6569	4737	-	-	-	-		6.71/38	6.92/38	7.11/38
4.18/28	4.33/28	4.45/28	4.54/27	4.58/26	4.56/25	4.43/24	3.86/23	-	-	-	-	12499	12121	11731	
10684	10240	9773	9272	8722	8095	7335	6268	-	-	-	-	12233	11846	11447	
4.56/30	4.72/30	4.85/29	4.95/29	5.01/27	5.03/26	4.96/25	4.74/24	-	-	-	-	6.21/36	6.42/36	6.59/36	
10888	10453	9996	9509	8979	8382	7676	6748	4850	-	-	-	6.21/36	6.42/36	6.59/36	
4.76/31	4.92/30	5.06/30	5.17/30	5.24/28	5.26/27	5.22/26	5.06/25	4.38/25	-	-	-	6.54/38	6.75/37	6.93/37	
11295	10875	10438	9976	9479	8932	8306	7547	6482	-	-	-	12499	12121	11731	
5.17/32	5.34/32	5.49/32	5.62/31	5.70/30	5.75/29	5.75/28	5.66/27	5.40/26	-	-	-	6.54/38	6.75/37	6.93/37	
11631	11224	10802	10358	9885	9370	8795	8123	7270	5883	-	-	12632	12257	11872	
5.53/34	5.71/33	5.87/33	6.00/33	6.11/32	6.17/31	6.19/30	6.15/29	5.99/28	5.52/28	-	-	6.71/38	6.92/38	7.11/38	
12233	11846	11447	11032	10594	10127	9618	9049	8386	7552	6248	-	6.71/38	6.92/38	7.11/38	
6.21/36	6.42/36	6.59/36	6.75/36	6.87/35	6.96/34	7.02/33	7.02/32	6.96/31	6.79/30	6.31/30	-	6.71/38	6.92/38	7.11/38	
12499	12121	11731	11327	10903	10452	9966	9430	8820	8085	7088	-	6.71/38	6.92/38	7.11/38	
6.54/38	6.75/37	6.93/37	7.09/37	7.22/37	7.33/36	7.39/35	7.42/33	7.39/32	7.27/32	6.97/31	-	6.71/38	6.92/38	7.11/38	
12632	12257	11872	11473	11055	10613	10137	9616	9028	8331	7424	5772	6.71/38	6.92/38	7.11/38	
6.71/38	6.92/38	7.11/38	7.27/37	7.41/37	7.51/36	7.59/35	7.62/34	7.60/33	7.50/32	7.26/32	6.51/31	6.71/38	6.92/38	7.11/38	

Performance certified is for installation type B - free inlet, ducted outlet.
 Power Ratings (BHP) does not include drive losses.
 Performance ratings do not include the effects of appurtenances in the airstream.

The sound ratings shown are loudness values in fan sones @ 5' (1.5m) in a hemispherical free field calculated per AMCA Standard 301. Values shown are for installation type A - free inlet fan sone levels.



S&PUSA Ventilation Systems, LLC., Div. of Soler & Palou Ventilation Group, certifies that the Models SQB shown herein are licensed to bear the AMCA Seal. The ratings shown are based on test and procedures performed in accordance with AMCA Publication 211 and AMCA Publication 311 and comply with the requirement of the AMCA Certified Ratings Program.





SQB 36

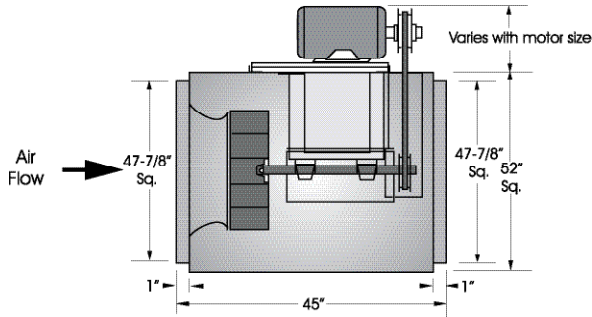

Outlet Velocity = CFM x 0.06
 Tip Speed = RPM x 9.344
 Maximum Motor Frame Size = 215T
 Maximum RPM = 725
 Maximum BHP at a Given RPM = (RPM/375)³

Unit Specifications
 Housing Metal Thickness = 16 GA.
 Approximate Weight = 600 lbs.

CFM / BHP @ Static Pressure / Sones												Drive Range	RPM	HP	Tip Speed
1/8	1/4	3/8	1/2	5/8	3/4	1	1-1/4	1-1/2	1-3/4	2					
7846 .62/6.5	6921 .65/6.0	5189 .60/5.9	-	-	-	-	-	-	-	-	-	DP 84	325	1	3031
8564 .76/7.5	7767 .81/7.0	6594 .80/6.6	-	-	-	-	-	-	-	-	-				
9270 .93/8.5	8565 .98/8.0	7632 1.00/7.5	5970 .93/7.5	-	-	-	-	-	-	-	-	DP 85	375	1	3497
9970 9.6	1.11 1.18/9.1	9335 1.21/8.6	8545 1.20/8.3	7421 -	-	-	-	-	-	-	-				
10663 1.33/10.8	10083 1.40/10.2	9392 1.44/9.7	8500 1.46/9.2	7081 1.38/9.2	-	-	-	-	-	-	-	DP 86	425	1-1/2	3964
11351 1.57/12.1	10817 1.64/11.5	10198 1.70/11.0	9445 1.73/10.4	8428 1.71/10.1	6431 1.50/10.1	-	-	-	-	-	-				
12035 1.83/13.5	11540 1.91/12.8	10978 1.98/12.2	10318 2.02/11.7	9496 2.03/11.2	8325 1.97/11.2	-	-	-	-	-	-	DP 87	475	2	4430
12717 2.13/14.8	12254 2.21/14.2	11737 2.29/13.7	11147 2.34/13.1	10446 2.37/12.5	9552 2.35/12.2	-	-	-	-	-	-				
13396 2.45/16.2	12961 2.55/15.6	12482 2.63/15.0	11946 2.69/14.5	11329 2.74/14.0	10587 2.75/13.5	7996 2.48/13.5	-	-	-	-	-	DP 88	525	3	4896
14072 2.81/17.7	13662 2.91/17.1	13215 3.00/16.5	12723 3.07/16.0	12168 3.13/15.4	11526 3.16/15.0	9697 3.06/14.7	-	-	-	-	-				
14747 3.20/19.2	14358 3.31/18.6	13939 3.40/18.1	13482 3.48/17.5	12977 3.55/17.0	12407 3.59/16.5	10925 3.57/15.8	7295 2.90/15.9	-	-	-	-	DP 89	575	5	5363
15420 3.62/21	15051 3.74/20	14655 3.84/19.6	14229 3.93/19.1	13764 4.01/18.6	13248 4.06/18.1	11979 4.09/17.1	9946 3.87/17.2	-	-	-	-				
16091 4.09/22	15740 4.20/22	15366 4.31/21	14965 4.41/21	14533 4.50/20	14060 4.56/19.7	12940 4.63/18.7	11369 4.54/18.5	-	-	-	-	DP 89	625	5	5829
16762 4.59/24	16426 4.71/23	16070 4.82/23	15693 4.93/22	15288 5.02/22	14851 5.10/21	13841 5.20/20	12528 5.18/19.6	10378 4.83/19.8	-	-	-				
17431 5.12/25	17109 5.25/25	16771 5.38/24	16413 5.49/24	16032 5.59/23	15625 5.68/23	14702 5.80/22	13559 5.83/21	11952 5.66/21	-	-	-	DP 89	675	7 1/2	6295
18100 5.70/27	17791 5.84/26	17467 5.97/26	17127 6.09/25	16768 6.19/25	16385 6.29/24	15533 6.44/23	14512 6.51/22	13188 6.44/22	11047 5.99/22	-	-				
18767 6.33/28	18471 6.47/28	18161 6.60/27	17836 6.73/27	17495 6.84/26	17134 6.95/26	16341 7.12/25	15414 7.22/24	14271 7.21/23	12685 6.98/23	8266 5.39/23	-	DP 89	725	7 1/2	6762

Performance certified is for installation type B - free inlet, ducted outlet.
 Power Ratings (BHP) does not include drive losses.
 Performance ratings do not include the effects of appurtenances in the airstream.

The sound ratings shown are loudness values in fan sones @ 5' (1.5m) in a hemispherical free field calculated per AMCA Standard 301. Values shown are for installation type A - free inlet fan sone levels.



S&P USA Ventilation Systems, LLC., Div. of Soler & Palau Ventilation Group, certifies that the Models SQB shown herein are licensed to bear the AMCA Seal. The ratings shown are based on test and procedures performed in accordance with AMCA Publication 211 and AMCA Publication 311 and comply with the requirement of the AMCA Certified Ratings Program.





SQBHP 36

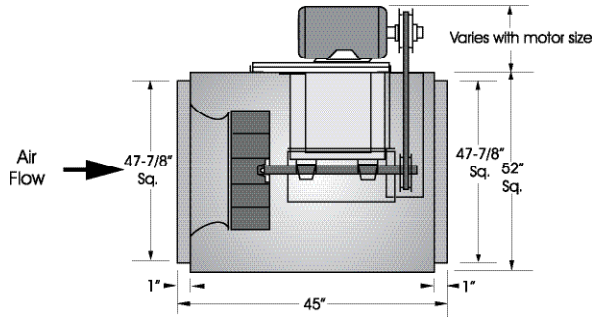

Outlet Velocity = CFM x 0.06
 Tip Speed = RPM x 9.344
 Maximum Motor Frame Size = 215T
 Maximum RPM = 840
 Maximum BHP at a Given RPM = (RPM/426)³

Unit Specifications

Housing Metal Thickness = 16 GA.
 Approximate Weight = 600 lbs.

CFM / BHP @ Static Pressure / Sones								Drive Range	RPM	HP	Tip Speed
3/4	1	1-1/4	1-1/2	1-3/4	2	2-1/4	2-1/2				
5958	-	-	-	-	-	-	-	DP 91	475	1-1/2	4430
1.32/10.3	-	-	-	-	-	-	-				
6880	-	-	-	-	-	-	-	DP 92	495	1-1/2	4617
1.55/11.2	-	-	-	-	-	-	-				
7969	-	-	-	-	-	-	-	DP 93	525	2	4896
1.87/12.7	-	-	-	-	-	-	-				
8761	6961	-	-	-	-	-	-	DP 94	550	2	5130
2.15/14.0	2.05/13.4	-	-	-	-	-	-				
9495	8081	-	-	-	-	-	-	DP 95	575	3	5363
2.44/15.3	2.43/14.6	-	-	-	-	-	-				
10192	8992	6855	-	-	-	-	-	DP 96	600	3	5596
2.75/16.7	2.79/16.0	2.53/15.6	-	-	-	-	-				
10863	9806	8278	-	-	-	-	-	DP 97	625	3	5829
3.08/18.2	3.15/17.5	3.07/16.8	-	-	-	-	-				
11514	10561	9310	6845	-	-	-	-	DP 98	650	5	6062
3.43/19.5	3.53/18.8	3.53/18.2	3.06/18.0	-	-	-	-				
12150	11276	10195	8598	-	-	-	-	DP 99	675	5	6295
3.81/21	3.93/20	3.97/19.6	3.81/19.1	-	-	-	-				
12773	11964	11001	9728	7136	-	-	-	DP 100	700	5	6529
4.21/22	4.35/22	4.43/21	4.37/20	3.74/20	-	-	-				
13386	12631	11756	10671	9070	-	-	-	DP 101	725	5	6762
4.64/24	4.80/23	4.91/22	4.91/22	4.68/21	-	-	-				
13508	12762	11903	10847	9334	-	-	-	DP 102	730	5	6808
4.73/24	4.89/23	5.00/23	5.02/22	4.82/22	-	-	-				
13750	13023	12192	11188	9817	-	-	-	DP 103	740	5	6902
4.91/24	5.08/24	5.20/23	5.24/23	5.10/22	-	-	-				
14589	13918	13169	12304	11235	9693	-	-	DP 104	775	7 1/2	7228
5.58/27	5.77/26	5.92/25	6.01/25	5.99/24	5.72/24	-	-				
15181	14544	13842	13048	12108	10889	8781	-	DP 105	800	7 1/2	7461
6.10/28	6.30/27	6.47/27	6.58/26	6.62/26	6.49/25	5.86/25	-				
15768	15160	14499	13763	12915	11881	10442	-	DP 106	825	7 1/2	7694
6.64/30	6.86/29	7.04/28	7.18/28	7.26/27	7.22/27	6.93/26	-				
16117	15526	14887	14180	13378	12422	11174	8932	DP 107	840	7 1/2	7834
6.98/31	7.21/30	7.40/29	7.56/29	7.65/28	7.65/28	7.46/27	6.65/27				

Performance certified is for installation type B - free inlet, ducted outlet.
 Power Ratings (BHP) does not include drive losses.
 Performance ratings do not include the effects of appurtenances in the airstream.

The sound ratings shown are loudness values in fan sones @ 5' (1.5m) in a hemispherical free field calculated per AMCA Standard 301. Values shown are for installation type A - free inlet fan sone levels.



S&P USA Ventilation Systems, LLC., Div. of Soler & Palau Ventilation Group, certifies that the Models SQB shown herein are licensed to bear the AMCA Seal. The ratings shown are based on test and procedures performed in accordance with AMCA Publication 211 and AMCA Publication 311 and comply with the requirement of the AMCA Certified Ratings Program.





SQB 42

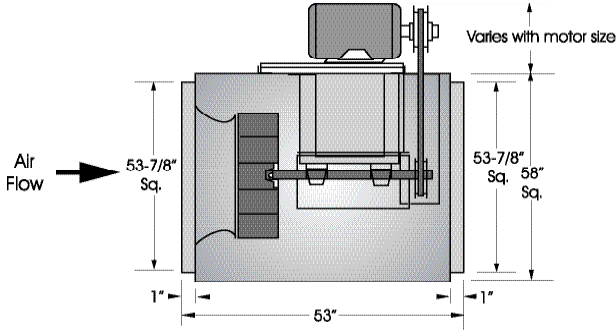

Outlet Velocity = CFM x 0.04
 Tip Speed = RPM x 10.995
 Maximum Motor Frame Size = 215T
 Maximum RPM = 565
 Maximum BHP at a Given RPM = $(RPM/289)^3$

Unit Specifications

Housing Metal Thickness = 16 GA.
 Approximate Weight = 725 lbs.

CFM / BHP @ Static Pressure / Sones								Drive Range	RPM	HP	Tip Speed
1/8	1/4	3/8	1/2	5/8	3/4	1	1-1/4				
11079 .96/7.9	8897 .94/8.3	-	-	-	-	-	-	DP 97	285	2	3134
12360 1.23/9.6	10509 1.23/10.2	7767 1.13/10.9	-	-	-	-	-		310	2	3409
13114 1.41/10.4	11406 1.42/11.1	9110 1.36/11.7	-	-	-	-	-		325	2	3574
14353 1.76/11.6	12829 1.77/12.2	10961 1.74/12.8	8114 1.58/13.5	-	-	-	-		350	2	3848
14843 1.91/12.1	13379 1.93/12.6	11629 1.91/13.3	9169 1.78/13.9	-	-	-	-		360	2	3958
15087 1.99/12.4	13651 2.01/12.9	11953 1.99/13.5	9638 1.88/14.1	-	-	-	-		365	2	4013
15573 2.16/12.9	14190 2.18/13.4	12583 2.17/14.0	10497 2.08/14.6	6669 1.71/15.4	-	-	-		375	3	4123
16299 2.42/13.7	14986 2.45/14.2	13494 2.45/14.7	11656 2.38/15.3	8917 2.17/16.0	-	-	-		390	3	4288
17498 2.91/15.1	16287 2.95/15.5	14945 2.96/15.9	13383 2.92/16.5	11381 2.80/17.2	8066 2.42/17.8	-	-		415	3	4563
17737 3.02/15.4	16543 3.06/15.7	15228 3.07/16.2	13708 3.03/16.8	11796 2.93/17.4	8831 2.60/18.0	-	-		420	3	4618
18213 3.24/16.0	17054 3.28/16.3	15786 3.29/16.8	14342 3.27/17.3	12581 3.18/17.9	10091 2.94/18.5	-	-	430	5	4728	
18925 3.59/17.0	17813 3.63/17.2	16609 3.65/17.7	15262 3.63/18.2	13676 3.57/18.8	11618 3.40/19.3	-	-	445	5	4893	
20106 4.22/18.8	19064 4.27/19.0	17950 4.29/19.3	16732 4.29/19.7	15353 4.25/20	13703 4.15/21	7488 3.17/22	-	470	5	5168	
21046 4.77/21	20053 4.83/21	19001 4.86/21	17865 4.87/21	16607 4.84/22	15158 4.77/22	10870 4.24/23	-	490	5	5388	
21281 4.92/21	20299 4.97/21	19261 5.01/22	18144 5.02/22	16911 5.00/22	15503 4.93/23	11477 4.46/24	-	495	5	5443	
22683 5.86/24	21765 5.92/24	20803 5.96/24	19782 5.99/25	18680 5.98/25	17463 5.94/26	14401 5.67/27	8269 4.39/28	525	7 1/2	5773	
23615 6.55/26	22734 6.62/26	21816 6.66/26	20849 6.69/27	19815 6.70/27	18692 6.68/28	15997 6.48/29	11784 5.76/30	545	7 1/2	5993	
24312 7.11/28	23457 7.17/28	22569 7.22/28	21638 7.26/28	20649 7.27/29	19584 7.25/30	17095 7.10/31	13563 6.57/32	560	7 1/2	6158	
24544 7.30/28	23697 7.36/28	22819 7.42/28	21899 7.45/29	20924 7.47/30	19877 7.45/30	17447 7.31/31	14082 6.83/33	565	7 1/2	6212	
								DP 98			
								DP 99			
								DP 100			

Performance certified is for installation type B - free inlet, ducted outlet.
 Power Ratings (BHP) does not include drive losses.
 Performance ratings do not include the effects of appurtenances in the airstream.

The sound ratings shown are loudness values in fan sones @ 5' (1.5m) in a hemispherical free field calculated per AMCA Standard 301. Values shown are for installation type A - free inlet fan sone levels.



S&P USA Ventilation Systems, LLC, Div. of Soler & Palau Ventilation Group, certifies that the Models SQB & SQD shown herein are licensed to bear the AMCA Seal. The ratings shown are based on test and procedures performed in accordance with AMCA Publication 211 and AMCA Publication 311 and comply with the requirement of the AMCA Certified Ratings Program.

