



# MODEL CFD

## Forward Curved Belt Driven Inline Duct Blower



### MODEL FEATURES

- Rated up to 5,800 CFM in static pressure applications up to 2-1/2" w.g.
- 5 sizes ranging from 7 to 15
- Single DWDI forward curved blower assembly with the motor located in the air stream
- Belt drives permit easy performance adjustments when needed
- Can be used in both horizontal & vertical air flow positions
- Removable access panels provide easy access for service
- AMCA Air & Sound Certified
- cULus Listed

### MODEL OVERVIEW

S&P's Forward Curved Belt Driven Inline Duct Blowers are designed for supply, exhaust or ducted return applications. The CFD is an economical fan model designed to run quietly and efficiently in cooling, heating, and ventilating applications.

The CFD was designed with several features to make life easier for the user. These features include: removable access panels with handles, adjustable motor pulleys for easy field adjusting, tight seals, and hanging rod connections.

A wide range of accessories and motors are available to meet special applications. These include: totally enclosed and two speed motors. Some of the accessory options available are: filter housings, hanging and floor mount isolators and insulated housings.

### STANDARD CONSTRUCTION FEATURES

**Horizontal Hanging Brackets**

**Forward Curved DWDI Blower**  
For efficient airflow and quiet performance.

**Removable Access Panel**  
For easy access for service

**AMCA Seal**  
Assures certified rating of air and sound performance.

**cULus 705 Listed**  
For electrical reliability.

**Factory Run & Tested**  
For quality assurance and dependable operation.

**Galvanized Steel Housing**  
Encloses blower, motor and drives.

**Bearings**  
Heavy-duty, ball bearing are designed for minimum 200,000 hours of operation, L50.

**Inlet and Outlet Duct Connectors**

Model CFD is available in our Quickship program. All sizes are available for next day shipping from stock.

**2 year fan housing warranty, 1 year motor warranty**



# CONSTRUCTION/SPECIFICATION CHECKLIST

## Fan Housing

- Statically and dynamically balanced forward curved wheel
- 12-gauge galvanized steel blower plate/discharge opening
- 18-gauge galvanized steel housing
- Prepunched mounting holes
- Conduit opening for wiring from below unit

## Drives

- Adjustable motor pulleys are standard
- Sized for minimum 150% of drive horsepower
- Machined cast iron adjustable motor pulleys
- Pivoting motor plate for belt tensioning
- Nonstatic oil resistant V-belts

## Bearings

- Heavy-duty bearings are designed for minimum 200,000 hour life, L50
- Bearings are sealed and prelubricated

## Motors

- 1 year warranty.
- Brands are nationally recognized and locally serviced
- Single speed open drip-proof are standard
- Totally enclosed and two-speed motors are available
- All motors are rated for continuous duty
- 182T and larger motors shipped unmounted for field installation
- Disconnect switch standard with single speed drip-proof and totally enclosed motor

## Certifications

- AMCA Air and Sound Certified
- cULus 705 Listed

## Entire Fan Unit

- Factory assembled and tested prior to shipment for quality assurance

## Dimensional Data

Dimensions in Inches

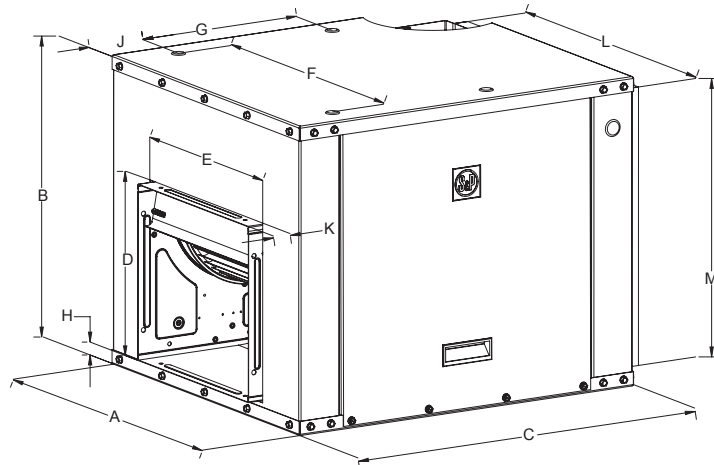

Model	A	B	C	D	E	F	G	H	J	K	L	M	Shaft (MM/IN)	WT (LBS)
7	18	15-3/8	23	8-1/4	9-1/4	14	7-11/16	1-1/4	1-7/8	5/8	15-7/8	13-3/8	20/.75	43
9	21	18	23	10-1/4	11-13/16	17	10-1/4	1-1/4	3-1/8	7/8	19	16	20/.75	55
10	22-1/4	20	24-3/4	11-1/4	13-1/8	18-1/4	11-3/8	1-1/4	3-11/16	15/16	20-1/4	18	20/.75	65
12	27	23	27-1/2	13-7/16	15-5/8	23	13-1/8	1-1/4	2-3/4	1-1/4	25	21	25/1	82
15	33-1/2	28	32	15-7/8	18-5/8	29-1/2	17-11/16	2-5/8	3	1	30-1/2	25	25/1	140

Metric Shafts have 'H' bushings installed to accommodate common pulleys



**OPTIONS/ACCESSORIES**

Filter Section

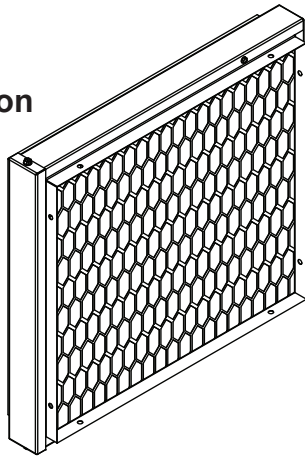

Rubber Isolator (Hanging)



Spring Isolator (Hanging)

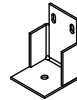
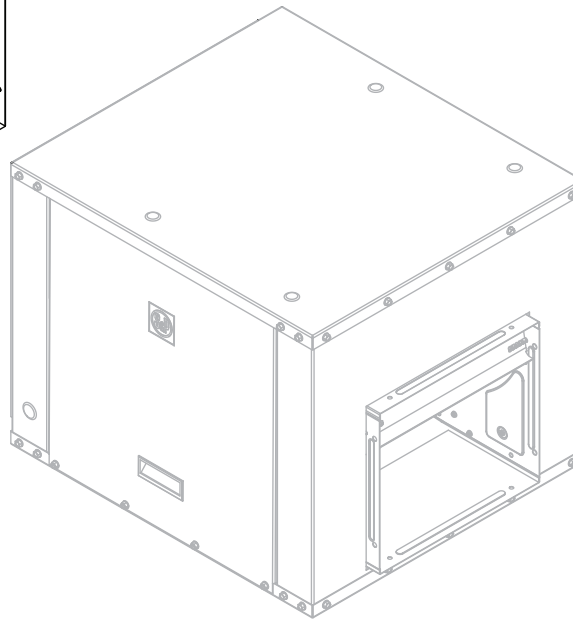

Rubber Isolator (Floor)

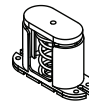

Spring Isolator (Floor)

**Hanging & Floor Brackets:** For base or ceiling mounting. Neoprene and spring isolators are available.

**Filter Section:** For applications with dusty or dirt laden air. The filters are easily removable for cleaning.

**Insulated Housing:** Used for condensation control or noise reduction.

**Disconnect Switch:** Nonfused safety disconnect available for all motor sizes and enclosures. Specify prewired if desired. (Wiring not available on explosion proof and two speed motors).



Filter Section

**Special Coatings:** For protective and decorative purposes. Available coatings include: Epoxy, Synthetic Resin and Heresite (air-dried phenolic). Contact your representative or the factory for more information on available coatings and colors.



# PERFORMANCE DATA

## CFD07

CFM	OV	0.125" SP		0.25" SP		0.375" SP		0.5" SP		0.625" SP		0.75" SP		1" SP		1.25" SP		1.5" SP		1.75" SP		2" SP		2.25" SP		2.5" SP	
		RPM	BHP	RPM	BHP	RPM	BHP	RPM	BHP	RPM	BHP	RPM	BHP	RPM	BHP	RPM	BHP	RPM	BHP	RPM	BHP	RPM	BHP	RPM	BHP	RPM	BHP
200	467	507	0.01	706	0.03	856	0.04	980	0.05	1088	0.07	1184	0.09	1354	0.13	1502	0.17	1634	0.21	1756	0.26	1869	0.31	1975	0.36	2074	0.42
300	701	530	0.02	719	0.03	872	0.05	1001	0.07	1114	0.09	1214	0.11	1391	0.16	1544	0.2	1682	0.26	1807	0.31	1923	0.37	2031	0.43	2133	0.49
400	934	579	0.03	741	0.05	886	0.06	1013	0.09	1127	0.11	1230	0.13	1412	0.19	1571	0.24	1712	0.3	1841	0.36	1960	0.42	2071	0.49	2176	0.56
500	1168	645	0.04	783	0.06	912	0.08	1031	0.11	1141	0.13	1242	0.16	1425	0.22	1586	0.28	1731	0.34	1863	0.41	1985	0.48	2099	0.56	2206	0.63
600	1401	720	0.06	840	0.08	953	0.11	1061	0.13	1163	0.16	1260	0.19	1438	0.25	1598	0.32	1744	0.39	1878	0.47	2002	0.54	2118	0.62	2227	0.71
700	1635	801	0.09	907	0.11	1007	0.14	1104	0.17	1197	0.2	1287	0.23	1456	0.29	1612	0.37	1756	0.45	1890	0.53	2015	0.61	2132	0.7	-	-
800	1868	885	0.12	981	0.15	1071	0.18	1158	0.21	1243	0.24	1325	0.27	1483	0.34	1632	0.42	1772	0.5	1903	0.59	2027	0.68	2144	0.77	-	-
900	2102	972	0.17	1059	0.2	1141	0.23	1221	0.26	1298	0.29	1374	0.33	1520	0.4	1660	0.49	1793	0.57	1920	0.66	2041	0.76	-	-	-	-
1000	2335	1061	0.22	1141	0.26	1217	0.29	1290	0.32	1361	0.36	1430	0.4	1566	0.48	1697	0.56	1823	0.65	1944	0.74	-	-	-	-	-	-
1100	2569	1150	0.29	1225	0.33	1296	0.36	1363	0.4	1429	0.44	1494	0.48	1620	0.56	1742	0.65	1861	0.74	-	-	-	-	-	-	-	-
1200	2802	1241	0.37	1311	0.41	1377	0.45	1440	0.49	1502	0.53	1562	0.57	1679	0.66	1794	0.75	-	-	-	-	-	-	-	-	-	-
1300	3036	1333	0.46	1398	0.51	1460	0.55	1520	0.59	1577	0.63	1634	0.68	1744	0.77	-	-	-	-	-	-	-	-	-	-	-	-
1400	3270	1426	0.57	1487	0.62	1545	0.66	1601	0.71	1655	0.75	-	-	-	-	-	-	-	-	-	-	-	-	-	-	-	-
1500	3503	1519	0.69	1576	0.74	-	-	-	-	-	-	-	-	-	-	-	-	-	-	-	-	-	-	-	-	-	-

## CFD09

CFM	OV	0.125" SP		0.25" SP		0.375" SP		0.5" SP		0.625" SP		0.75" SP		1" SP		1.25" SP	
		RPM	BHP	RPM	BHP	RPM	BHP	RPM	BHP	RPM	BHP	RPM	BHP	RPM	BHP	RPM	BHP
500	749	442	0.04	-	-	-	-	-	-	-	-	-	-	-	-	-	-
600	899	455	0.05	-	-	-	-	-	-	-	-	-	-	-	-	-	-
700	1049	481	0.06	624	0.1	-	-	-	-	-	-	-	-	-	-	-	-
800	1199	513	0.08	634	0.12	-	-	-	-	-	-	-	-	-	-	-	-
900	1349	550	0.1	655	0.14	766	0.2	-	-	-	-	-	-	-	-	-	-
1000	1499	588	0.13	683	0.17	780	0.23	883	0.3	-	-	-	-	-	-	-	-
1100	1648	628	0.16	715	0.21	801	0.26	891	0.33	987	0.41	-	-	-	-	-	-
1200	1798	669	0.2	751	0.25	829	0.31	909	0.37	993	0.45	-	-	-	-	-	-
1300	1948	711	0.25	788	0.3	860	0.36	933	0.42	1008	0.5	1086	0.58	-	-	-	-
1400	2098	753	0.31	826	0.36	894	0.42	962	0.48	1030	0.55	1100	0.64	1248	0.83	-	-
1500	2248	795	0.37	866	0.43	930	0.49	993	0.55	1056	0.62	1120	0.7	1254	0.89	1397	1.12
1600	2398	838	0.44	906	0.5	968	0.56	1027	0.63	1086	0.7	1145	0.78	1267	0.96	-	-
1700	2548	881	0.51	947	0.58	1006	0.65	1063	0.72	1118	0.79	1173	0.87	1286	1.05	-	-
1800	2697	924	0.6	989	0.67	1046	0.74	1100	0.82	1152	0.89	1204	0.97	-	-	-	-
1900	2847	967	0.7	1031	0.77	1086	0.85	1138	0.93	1188	1	1237	1.09	-	-	-	-
2000	2997	1010	0.8	1073	0.89	1127	0.97	1176	1.05	1225	1.13	-	-	-	-	-	-
2100	3147	1054	0.92	1115	1.01	1167	1.09	-	-	-	-	-	-	-	-	-	-
2200	3297	1098	1.05	1158	1.14	-	-	-	-	-	-	-	-	-	-	-	-

Performance shown is for installation Type B free inlet, ducted outlet. Performance ratings do not include the effects of appurtenances. Power rating (BHP) does not include transmission losses.



S&P USA Ventilation Systems, LLC., Div. of Soler & Palau Ventilation Group certifies that the Models CFD shown herein are licensed to bear the AMCA Seal. The ratings shown are based on test and procedures performed in accordance with AMCA Publication 211 and AMCA Publication 311 and comply with the requirement of the AMCA Certified Ratings Program.





**CFD10**

CFM	OV	0.125" SP		0.25" SP		0.375" SP		0.5" SP		0.625" SP		0.75" SP		1" SP		1.25" SP		1.5" SP		1.75" SP		2" SP		2.25" SP		2.5" SP	
		RPM	BHP	RPM	BHP	RPM	BHP	RPM	BHP	RPM	BHP	RPM	BHP	RPM	BHP	RPM	BHP	RPM	BHP	RPM	BHP	RPM	BHP	RPM	BHP	RPM	BHP
400	474	372	0.02	512	0.04	617	0.07	707	0.09	785	0.12	856	0.15	982	0.21	1093	0.28	1193	0.36	1286	0.44	1371	0.52	1452	0.61	1528	0.71
500	593	380	0.03	521	0.05	627	0.08	718	0.1	795	0.13	866	0.17	992	0.23	1103	0.31	1204	0.39	1296	0.47	1382	0.56	1463	0.66	1539	0.76
600	711	389	0.04	529	0.06	637	0.09	728	0.12	807	0.15	877	0.19	1003	0.26	1114	0.34	1214	0.42	1307	0.51	1392	0.61	1473	0.71	1549	0.81
700	830	398	0.04	537	0.07	645	0.11	735	0.14	816	0.17	886	0.21	1014	0.29	1124	0.37	1226	0.46	1317	0.56	1403	0.66	1483	0.76	1560	0.87
800	949	408	0.05	546	0.09	653	0.12	744	0.16	825	0.2	897	0.24	1024	0.32	1134	0.41	1234	0.51	1327	0.61	1413	0.71	1494	0.82	1570	0.93
900	1067	420	0.06	554	0.1	662	0.14	752	0.18	832	0.22	904	0.27	1033	0.36	1144	0.45	1246	0.55	1339	0.66	1423	0.77	1504	0.88	1580	0.99
1000	1186	435	0.08	563	0.12	670	0.16	761	0.21	841	0.25	913	0.3	1042	0.4	1153	0.5	1254	0.6	1348	0.71	1435	0.83	1514	0.94	1590	1.07
1100	1304	452	0.1	574	0.14	679	0.18	769	0.23	849	0.28	921	0.33	1049	0.44	1162	0.54	1265	0.66	1358	0.77	1444	0.89	1524	1.01	-	-
1200	1423	472	0.11	585	0.16	688	0.21	777	0.26	857	0.31	930	0.37	1058	0.48	1171	0.59	1274	0.71	1367	0.83	1454	0.96	1535	1.09	-	-
1300	1541	493	0.14	598	0.18	697	0.24	786	0.29	866	0.35	938	0.41	1066	0.53	1179	0.65	1281	0.77	1376	0.9	1463	1.03	-	-	-	-
1400	1660	513	0.16	613	0.21	708	0.27	795	0.33	874	0.39	946	0.45	1075	0.57	1188	0.7	1290	0.83	1383	0.97	1470	1.11	-	-	-	-
1500	1779	536	0.19	631	0.24	720	0.3	805	0.36	883	0.43	955	0.49	1083	0.63	1196	0.76	1298	0.9	1392	1.04	-	-	-	-	-	-
1600	1897	561	0.22	649	0.28	733	0.34	816	0.4	893	0.47	964	0.54	1091	0.68	1204	0.82	1307	0.97	1400	1.12	-	-	-	-	-	-
1700	2016	586	0.26	667	0.31	748	0.38	828	0.44	903	0.52	973	0.59	1100	0.74	1213	0.89	1315	1.04	-	-	-	-	-	-	-	-
1800	2134	612	0.3	688	0.36	764	0.42	840	0.49	914	0.57	982	0.64	1108	0.8	1221	0.96	1323	1.12	-	-	-	-	-	-	-	-
1900	2253	638	0.34	708	0.4	783	0.47	854	0.54	925	0.62	993	0.7	1117	0.86	1229	1.03	-	-	-	-	-	-	-	-	-	-
2000	2371	665	0.39	730	0.45	801	0.53	869	0.6	938	0.68	1004	0.76	1127	0.93	1238	1.11	-	-	-	-	-	-	-	-	-	-
2100	2490	692	0.45	754	0.51	821	0.58	886	0.66	952	0.74	1016	0.83	1137	1.01	-	-	-	-	-	-	-	-	-	-	-	-
2200	2608	720	0.51	778	0.58	841	0.65	905	0.73	966	0.81	1029	0.9	1147	1.08	-	-	-	-	-	-	-	-	-	-	-	-
2300	2727	747	0.58	802	0.64	861	0.72	923	0.8	982	0.88	1042	0.98	-	-	-	-	-	-	-	-	-	-	-	-	-	-
2400	2846	776	0.65	828	0.72	883	0.79	941	0.88	999	0.96	1057	1.06	-	-	-	-	-	-	-	-	-	-	-	-	-	-
2500	2964	804	0.73	853	0.8	906	0.88	961	0.96	1017	1.05	-	-	-	-	-	-	-	-	-	-	-	-	-	-	-	-
2600	3083	832	0.82	879	0.89	929	0.97	982	1.05	-	-	-	-	-	-	-	-	-	-	-	-	-	-	-	-	-	-
2700	3201	861	0.91	906	0.98	954	1.06	1004	1.15	-	-	-	-	-	-	-	-	-	-	-	-	-	-	-	-	-	-
2800	3320	889	1.01	933	1.08	-	-	-	-	-	-	-	-	-	-	-	-	-	-	-	-	-	-	-	-	-	-
2900	3438	918	1.12	-	-	-	-	-	-	-	-	-	-	-	-	-	-	-	-	-	-	-	-	-	-	-	-

Performance shown is for installation Type B free inlet, ducted outlet. Performance ratings do not include the effects of appurtenances. Power rating (BHP) does not include transmission losses.



S&P USA Ventilation Systems, LLC., Div. of Soler & Palau Ventilation Group certifies that the Models CFD shown herein are licensed to bear the AMCA Seal. The ratings shown are based on test and procedures performed in accordance with AMCA Publication 211 and AMCA Publication 311 and comply with the requirement of the AMCA Certified Ratings Program.





**CFD12**

CFM	OV	0.125" SP		0.25" SP		0.375" SP		0.5" SP		0.625" SP		0.75" SP		1" SP		1.25" SP		1.5" SP		1.75" SP		2" SP		2.25" SP		2.5" SP	
		RPM	BHP	RPM	BHP	RPM	BHP	RPM	BHP	RPM	BHP	RPM	BHP	RPM	BHP	RPM	BHP	RPM	BHP	RPM	BHP	RPM	BHP	RPM	BHP	RPM	BHP
800	678	345	0.05	475	0.09	573	0.13	654	0.18	724	0.23	787	0.28	896	0.39	992	0.51	1077	0.64	1155	0.77	1228	0.91	1296	1.05	1360	1.2
900	763	349	0.06	478	0.1	578	0.15	660	0.2	731	0.25	795	0.31	906	0.43	1003	0.55	1089	0.69	1168	0.82	1241	0.97	1309	1.12	1374	1.27
1000	848	351	0.06	481	0.11	582	0.16	666	0.22	738	0.27	802	0.34	915	0.46	1012	0.59	1100	0.73	1179	0.88	1253	1.03	1322	1.19	1387	1.35
1100	932	357	0.07	484	0.12	585	0.18	670	0.24	743	0.3	809	0.36	923	0.5	1021	0.64	1109	0.78	1190	0.94	1264	1.1	1333	1.26	1399	1.43
1200	1017	365	0.08	489	0.14	588	0.19	674	0.26	748	0.32	814	0.39	929	0.53	1029	0.68	1118	0.84	1199	1	1274	1.16	1344	1.33	1410	1.51
1300	1102	374	0.1	492	0.15	591	0.21	677	0.28	752	0.35	819	0.42	935	0.57	1036	0.73	1126	0.89	1208	1.05	1284	1.23	1354	1.41	-	-
1400	1187	384	0.11	495	0.17	596	0.23	680	0.3	755	0.38	823	0.45	941	0.61	1043	0.77	1134	0.94	1216	1.12	1292	1.3	1364	1.48	-	-
1500	1272	398	0.13	501	0.19	600	0.25	684	0.33	758	0.4	826	0.48	945	0.65	1048	0.82	1140	0.99	1224	1.18	1300	1.36	1372	1.56	-	-
1600	1356	415	0.15	508	0.21	603	0.28	688	0.35	761	0.43	829	0.52	949	0.69	1053	0.87	1146	1.05	1230	1.24	1308	1.44	-	-	-	-
1700	1441	425	0.17	516	0.23	606	0.3	691	0.38	764	0.46	832	0.55	953	0.73	1058	0.91	1151	1.11	1236	1.3	1314	1.51	-	-	-	-
1800	1526	435	0.2	525	0.26	612	0.33	695	0.41	769	0.5	835	0.59	956	0.77	1062	0.97	1156	1.17	1242	1.37	1321	1.58	-	-	-	-
1900	1611	450	0.22	535	0.29	618	0.36	699	0.45	772	0.53	840	0.63	959	0.82	1065	1.02	1160	1.23	1247	1.44	1326	1.66	-	-	-	-
2000	1695	465	0.25	545	0.32	625	0.4	702	0.48	776	0.57	844	0.67	962	0.87	1068	1.07	1164	1.29	1251	1.51	-	-	-	-	-	-
2100	1780	481	0.29	557	0.36	633	0.43	707	0.52	779	0.61	848	0.71	965	0.91	1071	1.13	1167	1.35	1255	1.58	-	-	-	-	-	-
2200	1865	496	0.32	571	0.4	642	0.47	714	0.56	783	0.66	851	0.76	969	0.97	1074	1.19	1171	1.42	1259	1.65	-	-	-	-	-	-
2300	1950	513	0.36	585	0.44	652	0.52	721	0.61	788	0.7	853	0.81	973	1.02	1077	1.25	1174	1.48	-	-	-	-	-	-	-	-
2400	2034	529	0.4	597	0.48	662	0.56	729	0.66	794	0.75	857	0.86	978	1.08	1080	1.31	1177	1.55	-	-	-	-	-	-	-	-
2500	2119	546	0.45	609	0.52	674	0.61	738	0.71	801	0.81	862	0.91	982	1.14	1085	1.38	1179	1.63	-	-	-	-	-	-	-	-
2600	2204	563	0.5	624	0.57	685	0.67	747	0.76	808	0.87	868	0.97	985	1.2	1089	1.45	-	-	-	-	-	-	-	-	-	-
2700	2289	580	0.55	638	0.62	701	0.73	757	0.82	817	0.93	875	1.04	989	1.27	1093	1.52	-	-	-	-	-	-	-	-	-	-
2800	2373	597	0.61	653	0.7	715	0.79	768	0.89	825	0.99	882	1.1	991	1.34	1097	1.6	-	-	-	-	-	-	-	-	-	-
2900	2458	615	0.67	669	0.76	729	0.86	779	0.96	835	1.06	890	1.17	996	1.42	-	-	-	-	-	-	-	-	-	-	-	-
3000	2543	632	0.74	684	0.83	740	0.93	791	1.03	845	1.14	898	1.25	1002	1.5	-	-	-	-	-	-	-	-	-	-	-	-
3100	2628	650	0.81	700	0.9	752	1	806	1.1	855	1.21	907	1.33	1009	1.58	-	-	-	-	-	-	-	-	-	-	-	-
3200	2713	668	0.88	716	0.98	766	1.08	821	1.19	866	1.3	917	1.42	-	-	-	-	-	-	-	-	-	-	-	-	-	-
3300	2797	685	0.96	733	1.06	781	1.16	834	1.27	878	1.39	927	1.51	-	-	-	-	-	-	-	-	-	-	-	-	-	-
3400	2882	703	1.05	749	1.15	796	1.25	846	1.36	890	1.48	937	1.6	-	-	-	-	-	-	-	-	-	-	-	-	-	-
3500	2967	721	1.14	766	1.24	811	1.35	857	1.46	906	1.58	-	-	-	-	-	-	-	-	-	-	-	-	-	-	-	-
3600	3052	740	1.23	783	1.34	826	1.45	871	1.56	-	-	-	-	-	-	-	-	-	-	-	-	-	-	-	-	-	-
3700	3136	758	1.33	800	1.44	842	1.55	885	1.67	-	-	-	-	-	-	-	-	-	-	-	-	-	-	-	-	-	-
3800	3221	776	1.44	817	1.55	858	1.66	-	-	-	-	-	-	-	-	-	-	-	-	-	-	-	-	-	-	-	-
3900	3306	794	1.55	834	1.66	-	-	-	-	-	-	-	-	-	-	-	-	-	-	-	-	-	-	-	-	-	-
4000	3391	813	1.66	-	-	-	-	-	-	-	-	-	-	-	-	-	-	-	-	-	-	-	-	-	-	-	-

Performance shown is for installation Type B free inlet, ducted outlet. Performance ratings do not include the effects of appurtenances. Power rating (BHP) does not include transmission losses.



S&P USA Ventilation Systems, LLC., Div. of Soler & Palau Ventilation Group certifies that the Models CFD shown herein are licensed to bear the AMCA Seal. The ratings shown are based on test and procedures performed in accordance with AMCA Publication 211 and AMCA Publication 311 and comply with the requirement of the AMCA Certified Ratings Program.





### CFD15

CFM	OV	0.125" SP		0.25" SP		0.375" SP		0.5" SP		0.625" SP		0.75" SP		1" SP		1.25" SP	
		RPM	BHP	RPM	BHP	RPM	BHP	RPM	BHP	RPM	BHP	RPM	BHP	RPM	BHP	RPM	BHP
1700	1039	283	0.11	-	-	-	-	-	-	-	-	-	-	-	-	-	-
1800	1100	289	0.12	-	-	-	-	-	-	-	-	-	-	-	-	-	-
1900	1161	295	0.13	-	-	-	-	-	-	-	-	-	-	-	-	-	-
2000	1222	302	0.15	-	-	-	-	-	-	-	-	-	-	-	-	-	-
2100	1283	310	0.16	-	-	-	-	-	-	-	-	-	-	-	-	-	-
2200	1345	318	0.18	-	-	-	-	-	-	-	-	-	-	-	-	-	-
2300	1406	326	0.2	396	0.27	-	-	-	-	-	-	-	-	-	-	-	-
2400	1467	335	0.22	401	0.29	-	-	-	-	-	-	-	-	-	-	-	-
2500	1528	344	0.25	406	0.31	-	-	-	-	-	-	-	-	-	-	-	-
2600	1589	354	0.27	412	0.34	-	-	-	-	-	-	-	-	-	-	-	-
2700	1650	363	0.3	418	0.37	-	-	-	-	-	-	-	-	-	-	-	-
2800	1711	373	0.33	425	0.4	-	-	-	-	-	-	-	-	-	-	-	-
2900	1772	383	0.36	433	0.43	489	0.52	549	0.62	-	-	-	-	-	-	-	-
3000	1834	393	0.4	441	0.47	494	0.55	551	0.65	-	-	-	-	-	-	-	-
3100	1895	403	0.44	449	0.5	499	0.59	554	0.69	-	-	-	-	-	-	-	-
3200	1956	414	0.48	457	0.54	505	0.62	558	0.73	-	-	-	-	-	-	-	-
3300	2017	424	0.52	466	0.58	512	0.67	562	0.77	615	0.88	-	-	-	-	-	-
3400	2078	434	0.56	475	0.63	519	0.71	567	0.81	618	0.93	-	-	-	-	-	-
3500	2139	445	0.61	484	0.68	526	0.76	572	0.86	621	0.98	672	1.1	-	-	-	-
3600	2200	456	0.66	493	0.72	534	0.81	578	0.91	625	1.03	674	1.15	-	-	-	-
3700	2261	466	0.71	502	0.78	542	0.86	584	0.96	629	1.08	676	1.22	-	-	-	-
3800	2322	477	0.77	512	0.83	550	0.92	590	1.02	634	1.14	679	1.26	770	1.54	-	-
3900	2384	488	0.82	522	0.89	558	0.98	597	1.08	639	1.19	683	1.33	774	1.6	-	-
4000	2445	499	0.88	532	0.96	567	1.04	604	1.14	645	1.25	687	1.39	775	1.66	-	-
4100	2506	510	0.95	541	1.02	575	1.11	612	1.21	651	1.32	691	1.45	777	1.73	-	-
4200	2567	521	1.02	552	1.09	585	1.17	620	1.28	657	1.39	696	1.52	779	1.8	-	-
4300	2628	532	1.09	562	1.17	594	1.25	628	1.35	664	1.46	701	1.58	781	1.88	-	-
4400	2689	543	1.16	572	1.24	603	1.32	636	1.42	671	1.54	707	1.66	785	1.96	865	2.27
4500	2750	554	1.24	582	1.32	612	1.4	644	1.5	678	1.62	713	1.74	788	2.03	867	2.35
4600	2811	565	1.31	593	1.4	622	1.48	653	1.59	685	1.7	720	1.82	792	2.11	869	2.43
4700	2873	576	1.4	603	1.48	632	1.57	662	1.67	693	1.79	726	1.91	796	2.2	871	2.52
4800	2934	587	1.48	614	1.57	641	1.66	670	1.76	701	1.94	733	2	801	2.28	873	2.61
4900	2995	599	1.58	624	1.66	651	1.75	679	1.86	709	2.03	740	2.1	806	2.38	876	2.71
5000	3056	610	1.67	635	1.76	661	1.85	689	1.95	718	2.13	748	2.19	812	2.47	880	2.81
5100	3117	621	1.77	645	1.86	671	1.95	698	2.05	726	2.23	755	2.3	818	2.58	884	2.91
5200	3178	632	1.87	656	1.97	681	2.05	707	2.16	735	2.35	763	2.4	824	2.68	888	3.01
5300	3239	644	1.98	667	2.07	691	2.16	717	2.27	744	2.39	771	2.51	830	2.79	893	3.12
5400	3300	655	2.09	678	2.19	702	2.28	727	2.38	753	2.5	780	2.63	837	2.91	898	3.23
5500	3361	666	2.2	689	2.3	712	2.4	736	2.5	762	2.62	788	2.75	844	3.03	-	-
5600	3423	677	2.32	699	2.42	722	2.52	746	2.62	771	2.74	797	2.87	851	3.15	-	-
5700	3484	689	2.44	710	2.55	733	2.65	756	2.75	780	2.87	805	3	-	-	-	-
5800	3545	700	2.57	721	2.67	743	2.78	766	2.88	790	3	814	3.13	-	-	-	-

Performance shown is for installation Type B free inlet, ducted outlet. Performance ratings do not include the effects of appurtenances. Power rating (BHP) does not include transmission losses.



S&P USA Ventilation Systems, LLC., Div. of Soler & Palau Ventilation Group certifies that the Models CFD shown herein are licensed to bear the AMCA Seal. The ratings shown are based on test and procedures performed in accordance with AMCA Publication 211 and AMCA Publication 311 and comply with the requirement of the AMCA Certified Ratings Program.





# SOUND DATA

## CFD07

RPM	Sound Performance Sones (Inches w.g.)												
	0.125	0.25	0.375	0.5	0.625	0.75	1	1.25	1.5	1.75	2	2.25	2.5
500	2	-	-	-	-	-	-	-	-	-	-	-	-
600	3.8	-	-	-	-	-	-	-	-	-	-	-	-
700	5.5	4.3	-	-	-	-	-	-	-	-	-	-	-
800	7.4	6.2	5.3	-	-	-	-	-	-	-	-	-	-
900	11.3	8.2	7.2	6.5	-	-	-	-	-	-	-	-	-
1000	11.7	10.4	9.3	8.5	7.9	-	-	-	-	-	-	-	-
1100	13.7	12.9	11.7	10.8	10	9.4	-	-	-	-	-	-	-
1200	27	15.9	14.3	13.3	12.5	11.8	-	-	-	-	-	-	-
1300	31	19.9	16.8	15.6	14.8	14.1	13.3	-	-	-	-	-	-
1400	34	24	19.2	18.2	17.3	16.5	15.7	-	-	-	-	-	-
1500	37	28	23	21	20	19.2	18.1	17.6	-	-	-	-	-
1600	39	32	27	23	23	22	21	20	19.6	-	-	-	-
1700	42	35	31	27	26	25	24	23	22	22	-	-	-
1800	43	38	34	31	29	28	27	26	25	24	24	-	-
1900	45	41	38	35	33	32	30	29	28	27	27	26	26
2000	47	44	41	39	38	36	34	32	31	30	30	30	29
2100	50	48	46	44	43	41	39	37	35	34	33	33	32
2200	55	53	51	50	48	46	43	41	39	38	37	36	36

## CFD09

RPM	Sound Performance Sones (Inches w.g.)							
	0.125	0.25	0.375	0.5	0.625	0.75	1	1.25
400	4.4	-	-	-	-	-	-	-
450	5.5	-	-	-	-	-	-	-
500	6.8	-	-	-	-	-	-	-
550	8.3	8.1	-	-	-	-	-	-
600	10	9.4	-	-	-	-	-	-
650	12.2	11.5	-	-	-	-	-	-
700	14.4	13.8	13.4	-	-	-	-	-
750	16.8	16.2	15.6	-	-	-	-	-
800	19.1	18.6	18	17.8	-	-	-	-
850	21	21	20	20	20	-	-	-
900	24	23	23	23	22	-	-	-
950	26	26	26	25	25	-	-	-
1000	29	29	29	28	28	28	-	-
1050	32	32	32	31	31	31	-	-
1100	35	35	34	34	34	33	-	-
1150	37	37	37	36	36	36	36	-
1200	40	40	39	39	39	39	38	-
1250	43	43	42	42	42	41	41	41
1300	47	46	46	45	45	44	44	43



S&P USA Ventilation Systems, LLC., Div. of Soler & Palau Ventilation Group certifies that the Models CFD shown herein are licensed to bear the AMCA Seal. The ratings shown are based on test and procedures performed in accordance with AMCA Publication 211 and AMCA Publication 311 and comply with the requirement of the AMCA Certified Ratings Program.

The sound ratings shown are in loudness values in fan sones at 1.5 m (5 ft) in a hemispherical free field calculated per AMCA International Standard 301. Values shown are for Installation type B: free inlet hemispherical sone levels.





**CFD10**

RPM	Sound Performance Sones (Inches w.g.)												
	0.125	0.25	0.375	0.5	0.625	0.75	1	1.25	1.5	1.75	2	2.25	2.5
400	2.7	-	-	-	-	-	-	-	-	-	-	-	-
450	4.4	-	-	-	-	-	-	-	-	-	-	-	-
500	6	3.1	-	-	-	-	-	-	-	-	-	-	-
550	7.6	4.8	-	-	-	-	-	-	-	-	-	-	-
600	9.3	6.7	4.6	-	-	-	-	-	-	-	-	-	-
650	11	8.8	6.2	-	-	-	-	-	-	-	-	-	-
700	12.8	10.7	8	6.2	-	-	-	-	-	-	-	-	-
750	14.4	12.5	10.2	7.8	6.9	-	-	-	-	-	-	-	-
800	16.2	14.4	12.5	9.9	7.9	-	-	-	-	-	-	-	-
850	18	16.4	14.5	12.2	9.9	8.6	-	-	-	-	-	-	-
900	19.8	18.5	16.6	14.6	12.2	10.2	-	-	-	-	-	-	-
950	22	21	18.8	17.1	14.7	12.5	-	-	-	-	-	-	-
1000	24	23	21	19.3	17.3	15	11.5	-	-	-	-	-	-
1050	26	25	23	21	20	17.6	13.8	-	-	-	-	-	-
1100	28	27	25	24	22	20	16.2	13.7	-	-	-	-	-
1150	30	29	28	26	25	23	18.9	15.7	-	-	-	-	-
1200	32	31	30	29	27	26	22	18.3	16.2	-	-	-	-
1250	34	33	32	31	29	28	25	21	18.1	-	-	-	-
1300	37	36	35	34	32	30	28	24	21	18.7	-	-	-
1350	39	38	37	36	35	33	30	26	23	20	19.8	-	-
1400	42	41	40	39	37	36	33	30	26	23	21	-	-
1450	44	43	42	42	40	39	36	33	29	26	23	22	22
1500	47	46	45	44	43	42	38	36	32	29	26	24	24
1550	50	49	48	47	46	45	41	39	35	32	29	27	25
1600	53	52	51	50	49	48	45	42	39	35	32	30	27

The sound ratings shown are in loudness values in fan sones at 1.5 m (5 ft) in a hemispherical free field calculated per AMCA International Standard 301. Values shown are for Installation type B: free inlet hemispherical sone levels.



S&P USA Ventilation Systems, LLC., Div. of Soler & Palau Ventilation Group certifies that the Models CFD shown herein are licensed to bear the AMCA Seal. The ratings shown are based on test and procedures performed in accordance with AMCA Publication 211 and AMCA Publication 311 and comply with the requirement of the AMCA Certified Ratings Program.



### CFD12

RPM	Sound Performance Sones (Inches w.g.)												
	0.125	0.25	0.375	0.5	0.625	0.75	1	1.25	1.5	1.75	2	2.25	2.5
400	3.9	-	-	-	-	-	-	-	-	-	-	-	-
450	5.3	4	-	-	-	-	-	-	-	-	-	-	-
500	6.8	5.4	4.4	-	-	-	-	-	-	-	-	-	-
550	8.6	6.9	5.9	-	-	-	-	-	-	-	-	-	-
600	10.5	8.6	7.4	6.6	-	-	-	-	-	-	-	-	-
650	12.6	10.5	9.1	8.2	7.4	-	-	-	-	-	-	-	-
700	14.7	12.6	11	9.9	9.2	8.4	-	-	-	-	-	-	-
750	16.8	14.9	13	11.7	10.8	10	-	-	-	-	-	-	-
800	18.9	17.2	15.2	13.7	12.6	11.7	10.2	-	-	-	-	-	-
850	21	19.4	17.5	15.8	14.7	13.7	12	10.4	-	-	-	-	-
900	23	22	19.9	18.2	16.8	15.8	14	12.5	-	-	-	-	-
950	26	24	22	21	19.1	18	16.1	14.6	-	-	-	-	-
1000	28	27	25	23	22	20	18.4	16.7	15.3	-	-	-	-
1050	31	29	28	26	24	23	21	19	17.4	16.1	-	-	-
1100	33	32	30	29	27	25	23	21	19.8	18.4	-	-	-
1150	36	34	33	32	30	28	25	24	22	21	19.6	-	-
1200	39	37	36	35	33	31	28	26	25	23	22	21	-
1250	42	41	39	38	36	34	31	29	27	26	24	23	22
1300	45	44	42	41	40	38	34	32	30	28	27	26	25
1350	49	47	46	44	43	41	38	35	33	31	30	28	27
1400	52	51	49	48	47	45	41	39	36	34	33	31	30

### CFD15

RPM	Sound Performance Sones (Inches w.g.)							
	0.125	0.25	0.375	0.5	0.625	0.75	1	1.25
300	3.8	-	-	-	-	-	-	-
350	5.5	-	-	-	-	-	-	-
400	7.5	6.3	-	-	-	-	-	-
450	9.6	8.3	-	-	-	-	-	-
500	11.9	10.7	9.6	-	-	-	-	-
550	14.3	13.2	12.1	11.3	-	-	-	-
600	17	15.8	14.8	13.9	13.1	-	-	-
650	19.5	18.4	17.4	16.5	15.6	-	-	-
700	22	21	20	19.2	18.3	17.5	-	-
750	25	24	23	22	21	20	18.7	-
800	28	27	26	25	24	23	22	20
850	31	30	29	28	27	26	25	23
900	34	33	33	32	31	30	28	27
950	38	37	36	35	35	34	32	31
1000	42	41	40	40	39	38	36	35
1050	47	46	45	44	43	42	41	39
1100	51	50	50	49	48	47	46	44
1150	56	56	55	54	53	52	51	49
1200	62	61	60	59	58	58	56	55
1250	66	65	64	63	63	62	60	59
1300	70	69	69	68	67	66	65	63

The sound ratings shown are in loudness values in fan sones at 1.5 m (5 ft) in a hemispherical free field calculated per AMCA International Standard 301. Values shown are for Installation type B: free inlet hemispherical sone levels.



S&P USA Ventilation Systems, LLC., Div. of Soler & Palau Ventilation Group certifies that the Models CFD shown herein are licensed to bear the AMCA Seal. The ratings shown are based on test and procedures performed in accordance with AMCA Publication 211 and AMCA Publication 311 and comply with the requirement of the AMCA Certified Ratings Program.